

**BULLETIN 310B  
VOL 1**

**TECHNICAL MANUAL  
33 TELETYPEWRITER SETS  
RECEIVE-ONLY (RO)  
KEYBOARD SEND-RECEIVE (KSR)  
AUTOMATIC SEND-RECEIVE (ASR)**



**TELETYPE<sup>®</sup>  
CORPORATION**  
5555 TOUHY AVENUE, SKOKIE, ILLINOIS



**310B  
VOLUME 1**

**INTRODUCTION**

Bulletin 310B is a technical manual that provides general and specific information about the 33 Receive-Only (RO), Keyboard Send-Receive (KSR), and Automatic Send-Receive (ASR) Teletypewriter Sets and their component units.

Volume 1 contains a description of the 33 Teletypewriter Sets and gives installation instructions. Also included in Volume 1 is information on the disassembly and reassembly, lubrication, and principles of operation of the component units of the Teletypewriter Sets. Volume 2 includes adjustment information on all component units of 33 Teletypewriter Sets.

Each volume is made up of a group of appropriate, independent sections. They are separately identified by title and section number, and the pages of each section are numbered consecutively, independent of other sections. The identifying number of a section, a 9-digit number, appears on each page of the section, in the upper left corner of left-hand pages and the upper right corner of right-hand pages.

To locate specific information, refer to the table of contents. Find the name of the involved component in column one and the title of the section in column two. The correct 9-digit section will then be found in column three. The sections are arranged in the order shown in the table of contents. Turn to page one of the section indicated where the contents of that section will be found (except where a section is small and does not require a listing of contents).

The sections comprising this bulletin are now stocked separately and may be individually ordered if the entire bulletin is not required.



TABLE OF CONTENTS

<u>Equipment</u>	<u>Contents</u>	<u>Section</u>	<u>Issue</u>
Teletypewriter Set	General Description and Operation	574-100-101TC	1
Teletypewriter Set	Circuit Description	574-100-103TC	1
Teletypewriter Set	Installation	574-100-201TC	4
Teletypewriter Set	Removal and Replacement of Components	574-100-702TC	1
Keyboard	General Description and Principles of Operation	574-121-100TC	2
Keyboard	Lubrication	574-121-701TC	2
Keyboard	Disassembly and Reassembly	574-121-702TC	2
Typing Unit	General Description and Principles of Operation	574-122-100TC	2
Typing Unit	Lubrication	574-122-701TC	2
Typing Unit	Disassembly and Reassembly	574-122-702TC	2
Call Control Unit	General Description and Operation	574-123-100TC	1
Tape Reader	General Description and Principles of Operation	574-124-100TC	2
Tape Reader	Lubrication	574-124-701TC	2
Tape Reader	Disassembly and Reassembly	574-124-702TC	2
Tape Punch	General Description and Principles of Operation	574-125-100TC	2
Tape Punch	Lubrication	574-125-701TC	2
Tape Punch	Disassembly and Reassembly	574-125-702TC	2
Cover	General Description	574-126-100TC	2
Cover	Lubrication	574-126-701TC	1



33 TELETYPEWRITER SETS

GENERAL DESCRIPTION AND OPERATION

CONTENTS	PAGE	
1. GENERAL . . . . .	1	egraph lines, telephone networks, and radio channels.
2. TELETYPEWRITER SETS . . . . .	1	1.03 References to left, right, up, down, front, rear, etc consider the teletypewriter set as viewed by the teletypewriter operator.
RECEIVE-ONLY (RO) TELETYPEWRITER SET . . . . .	1	1.04 This section covers the following teletypewriter sets:
KEYBOARD SEND-RECEIVE (KSR) TELETYPEWRITER SET . . . . .	1	(a) Receive-Only (RO) Teletypewriter Set
AUTOMATIC SEND-RECEIVE (ASR) TELETYPEWRITER SET . . . . .	3	(b) Keyboard Send-Receive (KSR) Teletypewriter Set
3. COMPONENTS . . . . .	3	(c) Automatic Send-Receive (ASR) Teletypewriter Set
A. Typing Unit . . . . .	3	
B. Call Control Unit . . . . .	3	
C. Keyboard . . . . .	3	
D. Tape Punch . . . . .	3	
E. Tape Reader . . . . .	3	
4. SET FEATURES . . . . .	7	
5. TYPICAL APPLICATION . . . . .	8	
6. TECHNICAL DATA . . . . .	9	
1. GENERAL		
1.01 This section is issued to provide a general description and operation of the 33 teletypewriter set, describe a typical application, and give technical data. Formerly this information was contained in Section 574-100-102TC, 32 and 33 Teletypewriter Sets — Description which is hereby cancelled.		2. TELETYPEWRITER SETS
1.02 The 33 Teletypewriter Sets described in this section are electromechanical apparatus that provide terminal facilities for exchanging recorded communication via appropriate transmission facilities, including tel-		RECEIVE-ONLY (RO) TELETYPEWRITER SET (Figure 1)
		2.01 The RO set can only receive messages and print them on a paper copy. It has no transmitting capabilities. Essentially the RO consists of two components.
		(a) Typing unit
		(b) Call control unit
		KEYBOARD SEND-RECEIVE (KSR) TELETYPEWRITER SET (Figure 2)
		2.02 The KSR can receive and transmit messages, and print them on a paper copy or sprocket form. It consists of the following components.
		(a) Typing unit
		(b) Call control unit
		(c) Keyboard

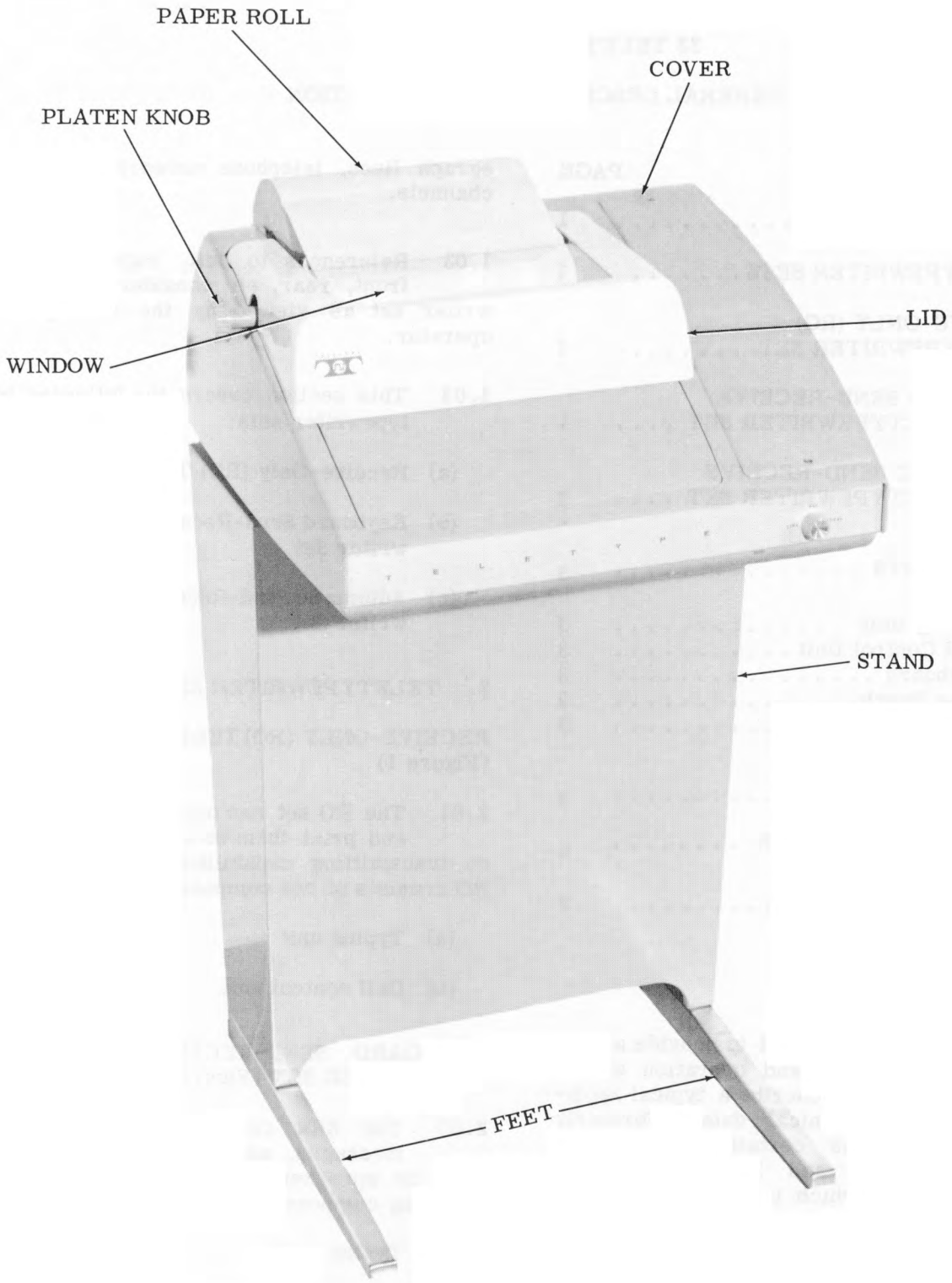

Figure 1 - Model 33 Receive-Only (RO)  
Teletypewriter Set



## AUTOMATIC SEND-RECEIVE (ASR) TELETYPEWRITER SET (Figure 3)

2.03 The ASR set consists of the following components:

- (a) Typing unit
- (b) Call control unit
- (c) Keyboard
- (d) Tape punch
- (e) Tape reader

2.04 The ASR set can receive and transmit messages. It can print messages on paper copy or on sprocket form. The tape punch perforates paper tape. The reader senses the code punched in tape which can then be transmitted to the local or distant set.

### 3. COMPONENTS

3.01 In this section, only a brief outline of the component operation will be presented. Individual components are described in detail each in a separate section. Refer to the following for a general description and principles of operation of the components:

Typing Unit	574-122-100TC
Call Control Unit	574-123-100TC
Keyboard	574-121-100TC
Tape Punch	574-125-100TC
Tape Reader	574-124-100TC

#### A. Typing Unit

3.02 The typing unit is the receiving component of the set. A signal coming into the typing unit is translated into a mechanical arrangement of codebars. The position of these codebars determines two things: the position of a type wheel upon which characters are embossed, and the selection of functions such as CARRIAGE RETURN and LINE FEED. A motor, by means of a main shaft, supplies all the motive force to effect the printing and perform the

functions. The friction feed set may be considered the standard type of set. It handles 8-1/2 inch paper, and will accommodate 74 characters per line, 10 characters per inch. Vertically the friction feed set will print 6 lines per inch and will normally print one original and one copy.

#### B. Call Control Unit

3.03 The call control unit serves as a bridge to electrically join the set to the communication networks. In some applications the call control unit serves to initiate, accept, control and complete the incoming calls. A power supply, local-remote control circuits, a selector magnet driver circuit, and a motor delay timer circuit are some of its basic elements.

#### C. Keyboard

3.04 The keyboard is the sending component of the set. Each of its keys controls an arrangement of levers which, in turn, position electrical contacts to represent the character. The keyboard output is a parallel output to the distributor of the typing unit. The distributor senses the keyboard output and sends it in a serial form to the selector magnet driver. From the selector magnet driver it then goes to the typing unit selector.

#### D. Tape Punch

3.05 The input to the tape punch is strictly mechanical. Extensions on the typing unit codebars position themselves in the tape punch to set up a similar coded arrangement of punch pins. With drive motion from the typing unit main shaft, the tape punch drives the punch pins to perforate holes in paper tape.

#### E. Tape Reader

3.06 Sensing pins in the tape reader are driven upward for every cycle. Where holes are present in the tape the sensing pins close a set of contacts. Where no holes are present in the tape the sensing pins are blocked and make no contact. These current, no-current conditions are duplicated on the typing unit distributor as a parallel output. The distributor senses the condition of each pulse and sends it serially to the selector magnet driver in the call control unit. From the call control unit the pulses go to the typing unit to print the character.

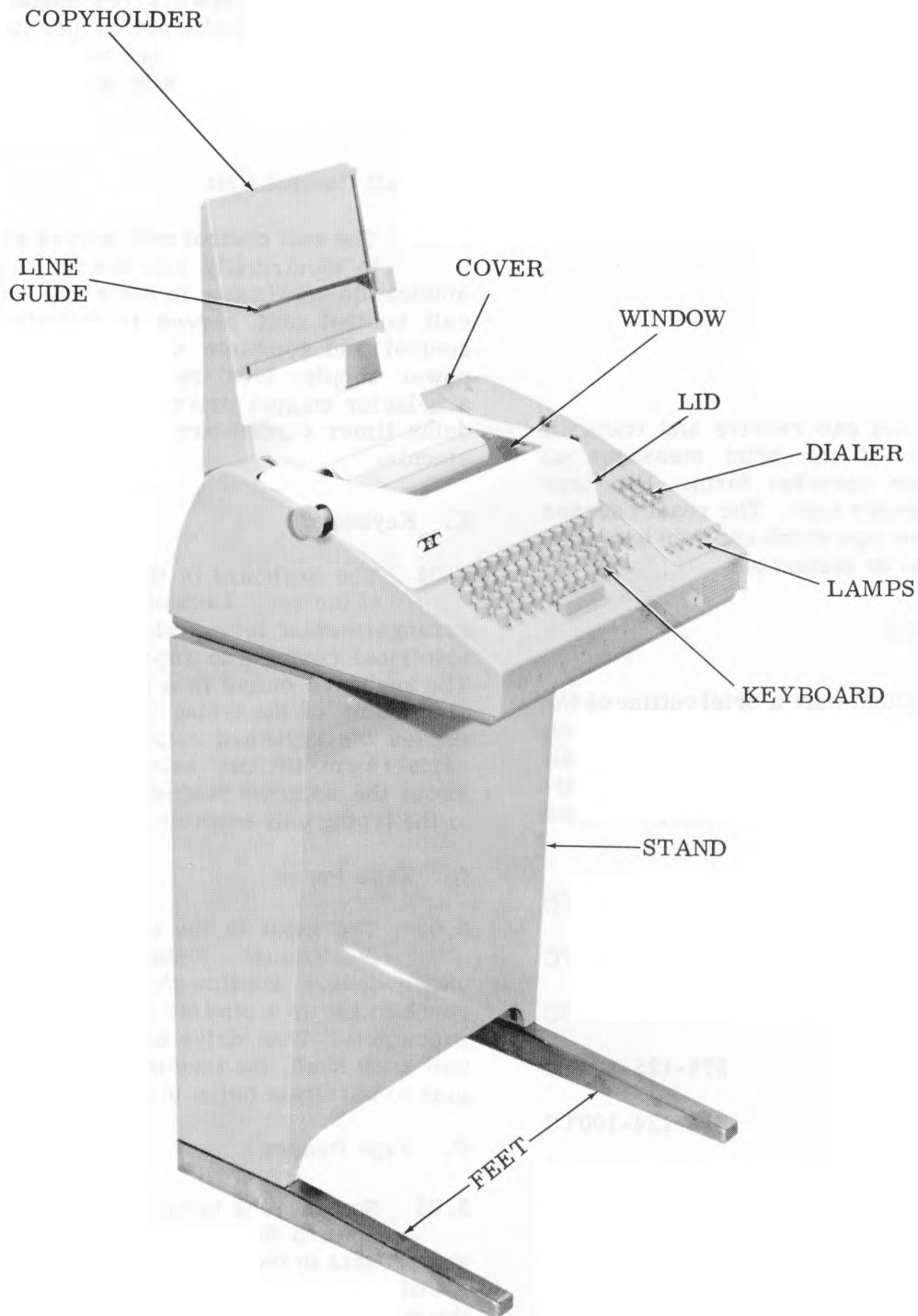

Figure 2 - Model 33 Keyboard Send-Receive (KSR) Teletypewriter Set

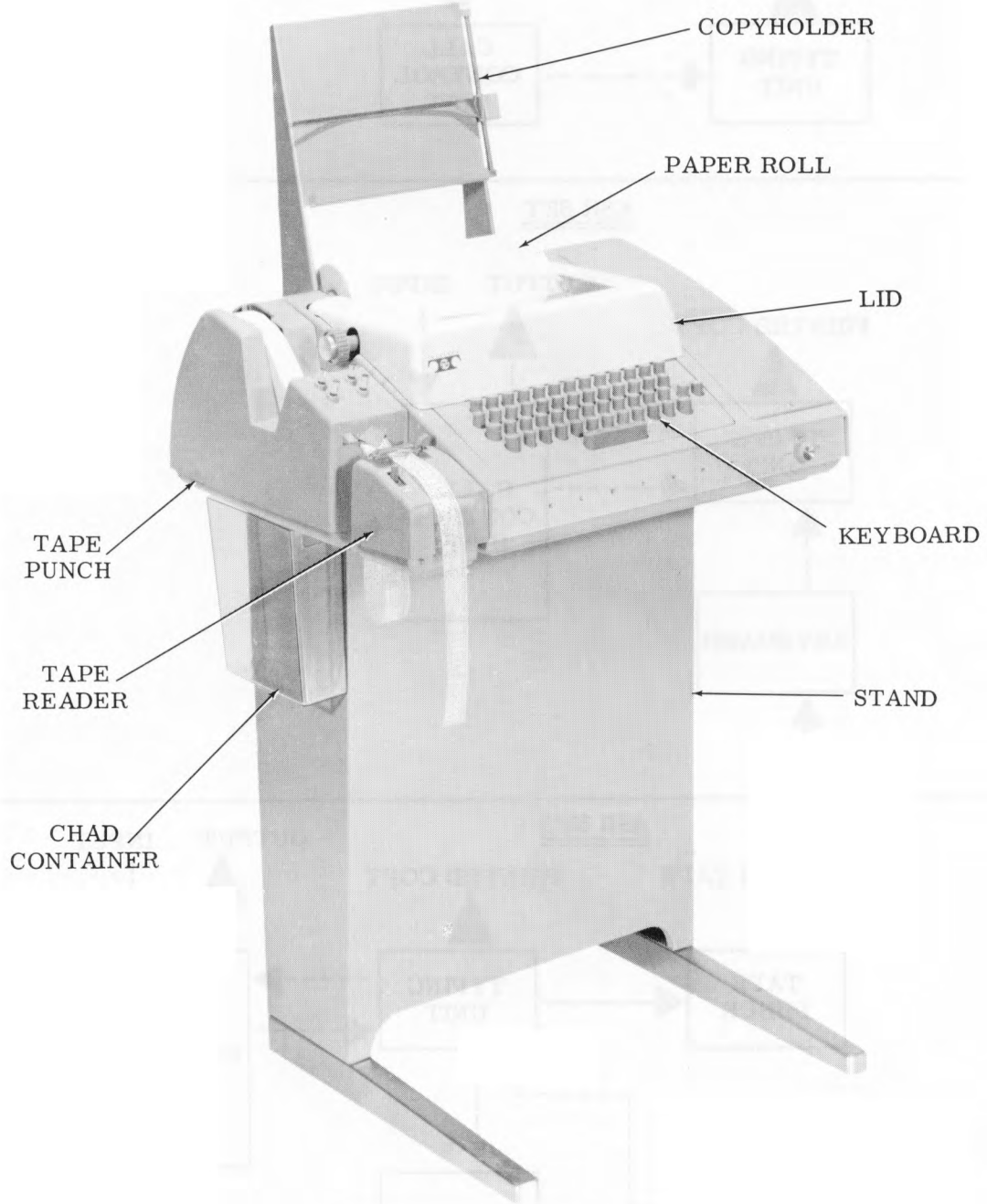

Figure 3 - Model 33 Automatic Send-Receive (ASR) Teletypewriter Set

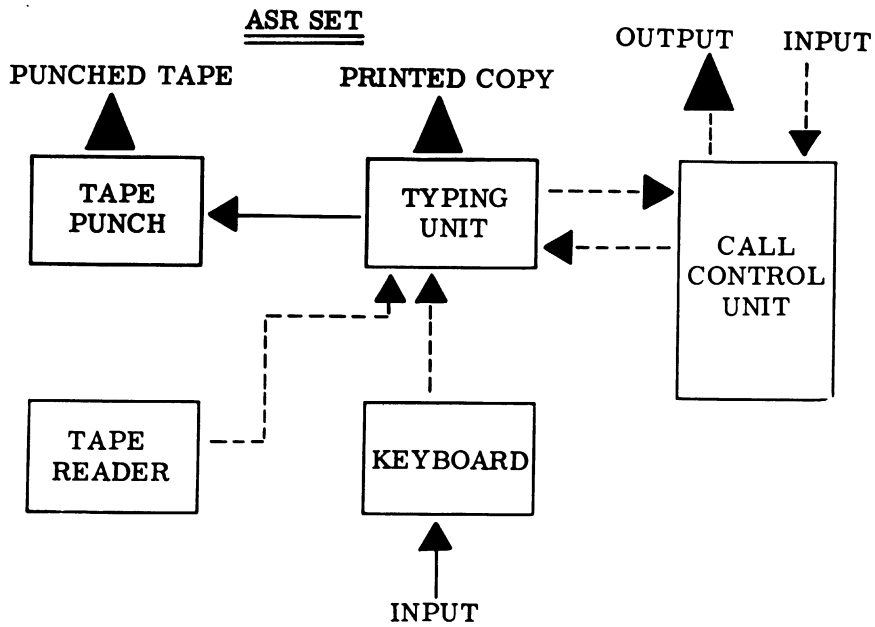
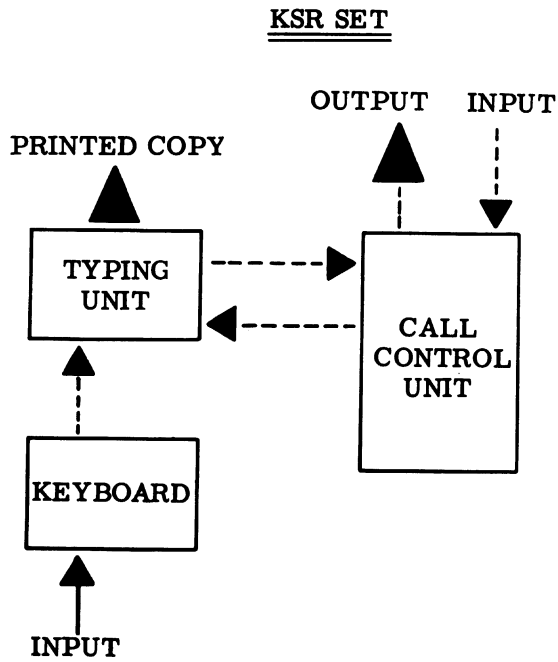
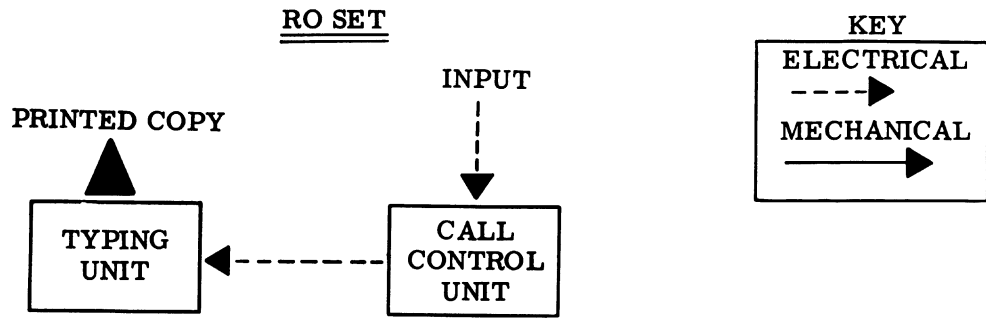

Figure 4 - Block Diagram of 33 Sets

## 4. SET FEATURES

**4.01 Standard Functions** — Functions refer to nonprinting operations performed by the set which are supplementary to its purpose of printing characters. All sets are equipped with the following standard functions.

### CARRIAGE RETURN

Upon command to CARRIAGE RETURN the movable printing mechanism returns to the left margin.

### LINE FEED

Advances the paper or sprocket form one or two lines.

### SPACE

Every character printed is spaced a certain distance from the previous one automatically. However the set can accept a separate command to SPACE in which case it will move the printing mechanism one character space to the right.

### SPACE SUPPRESSION

In some instances, such as when commands to CARRIAGE RETURN or LINE FEED are given, the set spacing mechanism is suppressed and no spacing occurs. Spacing is suppressed on all functions, except the SPACE function.

### PRINT SUPPRESSION

The printing mechanism is suppressed so that no printing occurs when the set receives commands to perform any of the functions.

### BLANK

The BLANK function serves to suppress printing.

**4.02 Even Parity Keyboard** — The 33 sets use seven intelligence pulses to accommodate the code combinations of the ASCII code (USA Standard Code for Information Interchange). The remaining eighth pulse is used as an error detection device. In sets so equipped the even parity keyboard adds an eighth marking pulse whenever the number of marking pulses in a code combination is odd. If the number of

marking pulses in a code combination is even, the eighth pulse is transmitted as a spacing pulse. This means that every code combination transmitted by the even parity keyboard has an even number of marking pulses.

Note: Keyboards not equipped with the even parity feature always transmit the eighth pulse as a marking pulse.

**4.03 Numeric Keyboard** — As the name implies, this optional feature consists of a keyboard with a numeric arrangement. It has no letters. This restricts the set for specialized applications where the exchange of data is of a numeric nature. Besides the numeric arrangement, the keyboard also transmits nonprinting functions such as EOT (End of Transmission), PACE, DELETE, CARRIAGE RETURN, LINE FEED, etc.

**4.04 Answer-Back** — In sets equipped with this feature, a mechanism coded with a predetermined sequence of characters is used for identification purposes. The mechanism may be actuated locally or remotely.

**4.05 Automatic Carriage Return-Line Feed** — This feature may be found on friction feed sets only; sprocket feed sets are unable to accommodate it. In sets so equipped, as printing approaches the end of the line the printing mechanism is returned to the left margin and the paper is advanced one line vertically.

**4.06 Sprocket-Feed** — Sprocket feed sets print characters on a sprocket fed form. Although the forms are 8-1/2 inches wide, they may be 6, 7, 8-1/2, 9, 10, or 11 inches in length. A total of 72 characters may be printed in a line on the form, with 10 characters per inch. The set will accommodate 6 lines of printed characters per inch. Varying with the weight of the carbon, the set will normally print one original and two copies. When the set has used all the forms available, an alarm will disable the set from accepting incoming calls.

**4.07 Form-Out (Sprocket Feed Only)** — In sets so equipped, the form-out mechanism advances the forms to a predetermined length upon command. The mechanism is adjustable to various form lengths.

**4.08 Paper-Out Alarm (Sprocket Feed Only)** — A set equipped with this feature will activate an alarm when the supply of forms is exhausted. The set will also refuse to accept any other incoming calls.

## SECTION 574-100-101TC

**4.09 Low Paper Alarm (Friction Feed Only)** — When the amount of paper on the roll reaches a certain amount, a switch activates an alarm which indicates to the operator that the paper supply is low.

**4.10 Automatic Punch Controls** — This feature allows a number of operating modes for turning the tape punch ON and OFF. The tape punch can be turned ON and OFF manually or automatically. An ON-LOCK feature which locks the tape punch in the ON mode is also available with the automatic punch.

**4.11 End of Line Bell** — Sets with this feature alert the operator that the printing mechanism is approaching the end of the line at the right margin.

**4.12 Print-Nonprint** — This solenoid mechanism disables a set so equipped from printing or performing functions when operated. When unoperated the set can print and execute its operations in normal fashion.

**4.13 Line Break** — This feature places the set so equipped in an open line condition. A BREAK key on the keyboard effects the operation.

**4.14 Repeat** — Sets equipped with this feature can print a character or perform a non-printing function continuously when the REPEAT key is depressed on the keyboard together with another key.

**4.15 TD Call In** — An ASR set having this feature can activate the tape reader of a distant set by momentarily closing a set of contacts. The tape reader can also be activated in two other ways: By closing a set of X-On (Reader On) contacts and by manually placing the tape reader in the ON mode.

**4.16 Copyholder** — The feature consists of a metal frame equipped with a page indicator. The frame mounts on the back of the set, facing the operator. Messages to be transmitted may be placed on the copyholder for convenience during transmission.

**4.17 End of Transmission (EOT)** — When equipped with this feature the sending set can indicate to the receiving set that the entire message has been sent out and transmission is terminated. The keyboard has an EOT key which will activate the mechanism.

**4.18 Accessories** — A number of accessories are available with the set, including the following:

(a) A sheet metal stand which supports the subbase and components at a convenient operating level. It consists of chrome feet, equipped with leveling screws or roller casters, and an enclosure to house auxiliary apparatus, such as a data set and the tape reader power pack.

(b) Call control facilities, including buttons, indicator lamps, motor control relay, speaker, ringer, buzzer, and rotary, TOUCH-TONE\*, or card dialers.

## 5. TYPICAL APPLICATION

**5.01** The following is a brief description of how 33 Teletypewriter Sets, equipped with call control and answer-back features, may be used in a typical communication system (Figure 5). When a call is to be made, an operator uses the controls on the teletypewriter set to gain access to the system switching and transmission facilities, which may be dial telephone or telegraph networks. The operator then dials the number of the called station.

**5.02** The switching center selects the proper station and signals the receiving station, indicated by visual and/or audible indicators. Using the controls on the teletypewriter set, the operator at the called station completes the connection and conditions the equipment so that communication can proceed in either direction. This is indicated visually and/or audibly at the calling station.

Note: Variations of call control features provide unattended reception of calls.

**5.03** Ordinarily the stations then identify themselves by the answer-back feature. The operator at the calling station can then type the message on the keyboard, or if it is an ASR set, can send it by perforated tape. In either case the teletypewriter set at the calling station translates the message to dc sequential start-stop signals which are applied to the transmission facilities. The teletypewriter sets at both the sending and receiving stations receive the signals and translate them to mechanical motions which print the message on continuous page copy or forms, and/or in the case of the ASR,

\*Registered Trademark of the Bell System

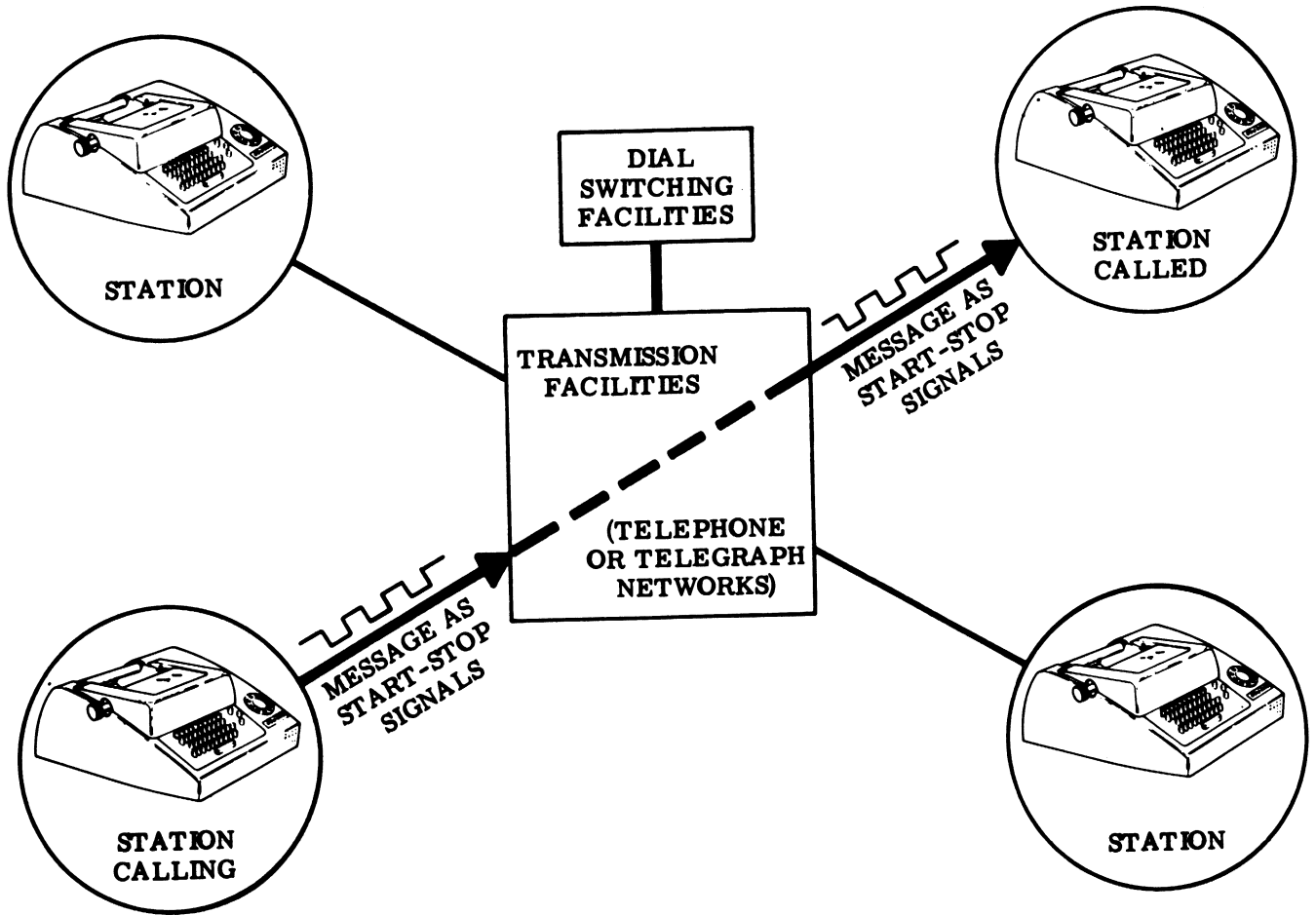

Figure 5 - Typical Applications

perforate it in tape. If telephone networks are used, the dc start-stop signals are converted to tone frequencies for transmission and reconverted to dc start-stop signals for reception.

5.04 Finally, the operator at either station can terminate the call and return the set to its idle condition by operating the OFF control. There are a variety of OFF controls, including the EOT key on the keyboard, a control knob, or a pushbutton on the call control unit. A set may be equipped with one or two of these controls. In the case of an RO set, only one OFF control is necessary. In the case of a KSR and ASR set, the EOT control on the keyboard or the pushbutton on the call control unit may be used.

## 6. TECHNICAL DATA

6.01 Speed: 100 words per minute  
600 operations per minute

6.02 Transmission Code: 8 level start-stop signals with 11 unit transmission pattern.

6.03 Dimensions and Weights (Approximate)

(a) RO Set

Width . . . . . 18-5/8 inches  
Depth . . . . . 18-1/2 inches  
Height . . . . . 8-3/8 inches  
Weight . . . . . 39 pounds

(b) KSR Set

Width . . . . . 18-5/8 inches  
Depth . . . . . 18-1/2 inches  
Height . . . . . 8-3/8 inches  
Weight . . . . . 40 pounds

SECTION 574-100-101TC

(c) ASR Set

Width . . . . . 22 inches  
Depth . . . . . 18-1/2 inches  
Height . . . . . 8-3/8 inches  
Weight . . . . . 44 pounds

(d) Stand

Width . . . . . 17-3/4 inches  
Height . . . . . 24-1/2 inches  
Depth (at top  
of enclosure) . . . . . 6-1/2 inches  
Length of Feet . . . . . 17-3/4 inches  
Weight . . . . . 12 pounds

6.04 Electrical Requirements

Power Requirements: 115 volts ac +10% 60  
hertz  $\pm$ 0.45 hertz, single phase

Signal Line Current: 0.020 or 0.060 ampere  
Nominal Input to 0.500 ampere at 20  
Selector: volts dc

Operating Margins:

All signal contacts and distributor:

Long Telegraph Loops: 0.015 to 0.070 ampere  
at 48 to 240 volts dc inductive

Short Telegraph Loops: 0.058 to 0.072 am-  
pere at 16 to 22 volts dc resistive



33 TELETYPEWRITER SETS

CIRCUIT DESCRIPTIONS

CONTENTS	PAGE	CONTENTS	PAGE
1. GENERAL . . . . .	2	EOT DISCONNECT CIRCUITS . . . . .	11
2. SWITCHED NETWORK SERVICE . . . . .	2	RINGER AND OFF-HOOK CIRCUITS . . . . .	11
TEST CIRCUIT . . . . .	2	OUT OF SERVICE CIRCUIT . . . . .	12
BREAK RELEASE CIRCUIT . . . . .	2	PAPER ALARM CIRCUIT . . . . .	12
RESTRAIN CIRCUIT . . . . .	3	POWER CIRCUITS . . . . .	13
CLEAR KEY CIRCUIT . . . . .	3	3. CIRCUIT SWITCHING SERVICE . . . . .	13
ANSWER CIRCUITS . . . . .	3	POWER SUPPLY CIRCUIT . . . . .	13
A. Automatic Answer . . . . .	3	LOCAL-REMOTE CONTROL CIRCUITS . . . . .	13
B. Manual Answer . . . . .	3	A. Proceed-to-Dial Circuit . . . . .	14
ORIGINATE CIRCUIT . . . . .	4	B. Connect Circuit . . . . .	15
ROTARY DIAL OR PULSING CARD		C. Local Circuit . . . . .	17
DIALER CIRCUIT . . . . .	4	MOTOR DELAY TIMER CIRCUIT . . . . .	17
A. On-Hook . . . . .	4	SELECTOR MAGNET DRIVER CIRCUIT . . . . .	19
B. Originating a Call . . . . .	4	NEUTRAL SIGNALING . . . . .	20
C. Answering a Call . . . . .	5	A. Circuit Interconnections . . . . .	20
"TOUCH-TONE"* DIALER CIRCUIT . . . . .	5	B. Idle Line Condition . . . . .	21
SPEAKER AMPLIFIER CIRCUIT . . . . .	5	C. Initiating a Call . . . . .	22
SIGNAL GENERATOR CIRCUITS . . . . .	6	D. Connection . . . . .	23
A. Signal Line Circuit . . . . .	6	E. Disconnect . . . . .	24
B. Signal Generation Circuit . . . . .	7	F. Local Off-Line Operation . . . . .	24
C. Control and Shift . . . . .	8	POLAR ADAPTER . . . . .	24
SELECTOR MAGNET DRIVER CIRCUIT . . . . .	8	A. General . . . . .	24
LOCAL AND MOTOR CONTROL CIRCUITS . . . . .	9	B. Receiving Polar Relay . . . . .	25
READER CONTROL CIRCUITS . . . . .	9	C. Sending Polar Relay . . . . .	26
ANSWER-BACK CIRCUITS . . . . .	11	D. Connect Control Timer . . . . .	26
		E. Current Amplifier . . . . .	27
		F. Circuit Interconnections . . . . .	28
		G. Idle Line Conditions . . . . .	28

\*Service mark of AT&T Company

CONTENTS	PAGE
H. Initiating a Call . . . . .	28
I. Proceed-to-Dial . . . . .	28
J. Dialing . . . . .	29
K. Call Connection . . . . .	29
L. Remote Connection . . . . .	30
M. Call Disconnect . . . . .	31
N. Remote Disconnect . . . . .	31
O. Local Off-Line Operation . . . . .	31
4. PRIVATE WIRE SERVICE . . . . .	31
INTRODUCTION . . . . .	31
A. Power Switch and Local Power Supply Circuits . . . . .	31
B. Mode Chart . . . . .	31
OFF MODE . . . . .	31
A. Power Circuit . . . . .	31
B. Signal Circuit . . . . .	33
LOCAL MODE . . . . .	33
A. Power Circuit . . . . .	33
B. Signal Circuit . . . . .	33
LINE MODE . . . . .	33
A. Power Circuit . . . . .	33
B. Signal Circuit . . . . .	33
1. GENERAL	
1.01 This section explains how various circuits are electrically coupled to a teletypewriter set, to a telegraph network or, through a data set to a telephone network.	
1.02 All circuit descriptions are made with respect to specific wiring diagrams. Alpha numeric references found in parentheses are used to located major components or circuits on the wiring diagrams. An example of a alpha numeric reference is (3C4), and should be read as follows:	
(a) The number 3 designates the sheet on which the particular circuit or component is located.	
(b) The letter and number combination C4 indicates the horizontal and vertical coordinates where the component or circuit is located.	
2. SWITCHED NETWORK SERVICE	
2.01 The KSR, ASR, and RO Teletypewriter Sets used in switched network service operate in conjunction with either a 101C or 105A data set and a call control unit.	

General descriptions and operations of the call control unit or either data set can be found in the appropriate sections.

2.02 The following circuit descriptions should be used with reference to 7882WD for KSR and ASR sets and 7881WD for RO sets.

**TEST CIRCUIT**

2.03 Operating the TST (test) pushbutton while the set is connected to a test center permits the message sent by the test center to be recorded by the typing unit and, at the same time, turned around and sent back to the test center for analysis.

2.04 The TST pushbutton is a locking type and may be released by momentarily depressing any of the five other pushbuttons in the six pushbutton set. When operated, the normally open contacts 23 and 24 (1D4) close to complete the 10-volt circuit through the TST lamp (located under the pushbutton) to ground.

2.05 The normally closed contacts 22 and 23 open to remove the data set from ground and disable timed disconnect-on-spacing feature. This is necessary to prevent a disconnect, should a steady spacing signal be included in a test.

2.06 The normally closed contacts 19 and 20 open to remove the keyboard or transmitter signal output at the send break timer from the modulator in the data set. The normally open contacts 19 and 21 close a circuit from the demodulator to the modulator, so that demodulated signals from the test center are modulated and sent back to the test center.

**BREAK-RELEASE CIRCUIT**

2.07 Set connected to 101C data set: The BRK-RLS (break-release) lamp lights when the RB (receive-break) relay operates, closing the RB make contacts. This completes the circuit from 14 v ac through the BRK-RLS lamp, the RB make contacts, and the S break contacts to ground.

2.08 The RB and the S (send space) relay operate after the CLR (clear) pushbutton is depressed. The BRK-RLS lamp may flash momentarily at this time. The opening of the S break contacts will prevent the BRK-RLS lamp from remaining on during the clear sequence.

2.09 Set connected to 105A data set: The SO (send space – normally operated) relay operates when the set is turned on. The BRK-RLS lamp lights when the RR (receive break – normally released) relay operates. The RR relay closes its make contacts which complete the circuit through 14 v ac through the BRK-RLS lamp, the RR make contacts, and SO make contacts to ground.

2.10 The RR relay operates and the SO relay releases after the CLR pushbutton is depressed. The BRK-RLS lamp may flash momentarily at this time. The opening of the SO break contacts prevent the BRK-RLS lamp from remaining on during the clear sequence.

#### RESTRAIN CIRCUIT

2.11 The REST (restrain) lamp lights when the RS (restrain signal) relay in the data set is energized. On a "break," which originates in the data converter, the REST and BRK-RLS lamps are both lighted.

Note: This circuit is found in KSR and ASR sets only.

#### CLEAR KEY CIRCUIT

2.12 Set connected to 101C data set: Momentarily depressing the nonlocking CLR pushbutton closes contacts 11 and 12. This will complete the circuit to ground in the following ways:

- (a) Answer Mode: The circuit is completed through the AN (answer) make contacts.
- (b) Originate Mode: The circuit is completed through the AN break contacts and the OR (originate) make contacts.

2.13 The complete circuit path is through the contacts mentioned in 2.12 (a) or (b), CLR contacts 11 and 12, the RB (receive break) contacts, and the RB relay to -20 v dc.

2.14 When the RB relay operates, the RB make contacts provide a holding circuit for the relay to ground through the AN make or AN break contacts and the OR make contacts, depending on the mode of the set. Other RB make contacts close to complete the circuit from ground through the AN make or AN break contacts, the OR make contacts, CLR contacts 11 and 12, RB make contacts, and the S relay to -20 v dc. The S relay operates and remains energized through the holding path provided by the AN make or AN break contacts and the OR make contacts. The S make contacts close and the CLR lamp will light. A timer circuit de-energizes the S relay after 700 milliseconds, the S make contacts open, and the clear lamp will turn off.

2.15 Set connected to 105A data set: The RO (receive break) and SO (send break) relays are normally operated, as designated by the letter O in RO and O in SO. When the CLR pushbutton is momentarily depressed, contacts 11 and 12 complete the circuit from ground through the CLR contacts, the RO make contacts, and the RR relay to -20 v dc. The RR relay operates and remains energized through its holding contacts.

2.16 The RR break contacts open the circuit to the RO relay and release the relay. The RO break contacts close the circuit from ground through the CLR contacts 11

and 12, the RO break contacts, and the SR relay to -20 v dc. The SR relay operates and is held by the SR make contacts. The SR make contacts (in series with the OH make contacts) close and light the CLR lamp. A timer circuit causes the OH (off hook) relay to release and turn off the CLR lamp.

#### ANSWER CIRCUIT

2.17 When a set is called, an ac ringing current, sent from the central office, energizes the RU (ring up) relay. The set may then be put into the answer condition either automatically or manually.

##### A. Automatic Answer

2.18 With the RU relay energized, the ANS (answer) lamp is lighted by the closure of the RU make contacts, which completes the circuit from ground through the lamp to +20 v dc.

2.19 Set connected to 101C data set: With the set in the automatic answer condition, there is a circuit path from -20 v dc through the AN (answer) relay, the RU make contacts, the CY (copy) break contacts, and CP17 to ground. The AN relay is held energized by the ground applied to its make contacts. The ANS lamp remains on because of the ground applied through the series connected AN make contacts and S break contacts.

2.20 The ANS lamp goes off when the S relay operates after the CLR pushbutton is depressed, or on the end of transmission code. The opening of the S break contacts in series with the S make contacts will turn off the ANS lamp. When the S relay operates, the S break contacts place a resistor in the circuit; the S make contacts provide a path to ground through the timer. After the timing interval during the disconnect sequence, the timer causes the AN relay to release by completing the path to ground which short-circuits the relay.

2.21 Set connected to 105A data set: With the set in the automatic answer condition, there is a circuit path from +20 v dc through the OH relay, the OR break contacts, the RU make contacts, the CY break contacts, and through CP17 to ground. The OH relay operates and is held energized by the circuit path through its make contacts, the SO make contacts, and the TM (timer) break contacts to ground.

2.22 The ANS lamp turns off when the SR relay is operated by depressing the CLR pushbutton, or at the end of the transmission code. The SR break contacts in series with the OR break contacts open to turn the lamp off. The OH relay releases when the SO make contacts and the TM break contacts open during the clearing sequence.

##### B. Manual Answer

2.23 The automatic answer feature is disabled when any one of the following contacts in the circuit through the AN or OH relay and the RU make contacts to ground is opened.

SECTION 574-100-103TC

<u>CONDITION OF SET</u>	<u>CONTACTS OPEN</u>
-------------------------	----------------------

Local, originate, or test modes	CY break
Low paper	Low paper switch
Out of service	Out of service
Feeding forms or tabulating	Vertical tabulation and form out

2.24 During the ringing interval, the RU relay operates causing the ANS lamp to flash and the ringer to sound. The RU relay releases during the silent interval. (If the set is out of service, no ringing will take place.)

2.25 The ANS pushbutton is depressed to answer a call. (If the set is feeding forms or tabulating at this time, the set will automatically answer after the operation is completed.) The ANS pushbutton is nonlocking, and its contacts 17 and 18 (1D7) close momentarily.

2.26 Set connected to 101C data set: Closure of the ANS pushbutton completes the circuit from ground through the S and OR break contacts, ANS contacts 17 and 18, and the AN relay to -20 v dc. The AN relay then operates and is held energized by the ground applied by the AN make contacts. Subsequent operation is the same as the automatic answer described in 2.19 and 2.20.

2.27 Set connected to 105A data set: Depressing the ANS pushbutton completes the circuit from ground through the SO make contacts, the ANS contacts 17 and 18, the OR break contacts, and the OH relay to +20 v dc. The OH relay operates and is held energized by the OH and SO make contacts to ground. Subsequent operation is the same as the automatic answer as described in 2.21 and 2.22.

**ORIGINATE CIRCUIT**

2.28 The RO set goes into the originate mode but has no amplifier.

2.29 Depressing the nonlocking ORIG (originate) pushbutton momentarily closes contacts 5 and 6 (1E7). This will start the following operations, provided the set is not in an answer condition.

2.30 Set connected to 101C data set: Depressing the ORIG pushbutton completes the circuit from ground through the S and AN break contacts, the ORIG contacts, and the OR relay to -20 v dc. The OR relay then operates and is held energized by the OR make contacts and AN break contacts to ground. The closure of the OR make contacts in series with the S break contacts turn on the ORIG lamp and makes the speaker amplifier operable by turning on output transistor Q2 (2E6).

2.31 After the CLR pushbutton is depressed, or upon receipt of the end of transmission code, the S relay operates and its break contacts (in series with the OR make contacts) open to turn off the ORIG lamp and disable the speaker amplifier. The OR relay releases during the disconnect sequence in the same manner as the AN relay releases as described in 2.20.

2.32 Set connected to 105A data set: Depressing the ORIG pushbutton completes the circuit from ground through the SO make contacts, the OH break contacts, the ORIG contacts 5 and 6, and the OR relay to +20 v dc. The OR relay then operates, its make contacts close and the OH relay will operate. The OR relay remains energized when the ORIG pushbutton contacts 5 and 6 open through the holding circuit composed of the OR, OH, and SO make contacts to ground.

2.33 The ORIG lamp lights with the closure of the OR and OH make contacts (in series with the SR break contacts). These contact closures also make the speaker amplifier operable by turning on output transistor Q2.

2.34 After the CLR pushbutton is depressed, or upon the receipt of the end of transmission code, the SR break contacts (in series with the OR and OH make contacts) open, turning off the ORIG lamp and disabling the speaker amplifier. Relays OR and OH release during the disconnect sequence in the same manner as the OH relay in 2.22.

**ROTARY DIAL OR PULSING CARD DIALER CIRCUIT**

2.35 The following circuit description applies to ASR and KSR sets only.

2.36 When originating or answering a call, the ringer is disconnected and the hybrid transformer is connected, between ring and tip, to present an off hook condition to the central office. Both the rotary dialer and pulsing card dialer have off-normal contacts which close and short circuit the speaker output during dialing. The operator, therefore, will not hear dialing clicks through the speaker.

**A. On-Hook**

2.37 When the set is in the on-hook condition, the ringer is connected between ring and tip through the AN break and OR break contacts (in the 101C data set) or, through the OH break contacts (in the 105A data set).

**B. Originating a Call**

2.38 Set connected to 101C data set: the OR relay operates, the OR break contacts open the ringer circuit, and the OR make contacts close the circuit from tip, through the pulsing contacts of the rotary dial (and the pulsing card dialer, if present), and through the hybrid transformer to the ring circuit.

2.39 Set connected to 105A data set: The OH relay operates and the OH break contacts open the ringer circuit. The OH make contacts close the circuit from tip, through the pulsing contacts of the rotary dial (and pulsing card dialer, if present), and through the hybrid transformer to the ring circuit. After the call connection is made, the CR (connect) make contacts or the CO (connect) break contacts close to short circuit the dialer pulsing contacts.

### C. Answering a Call

2.40 Set connected to 101C data set: During an automatic answer, the RU (ring up) break contacts (2C2) open and prevent ringing current from reaching the hybrid transformer when the AN contacts close. The AN relay is operated and the AN break contacts open the ringer circuit. The AN make contacts close the circuit from tip, through the OR break contacts, the AN make contacts, the RU break contacts, and the hybrid transformer, to the ring circuit. Since the set is in an answer condition, the dialer pulsing contacts are not in the circuit.

2.41 Set connected to 105A data set: During an automatic answer, the RU (2B2) break contacts open and prevent ringing current from reaching the hybrid transformer when the OH make contacts close. The OH relay is operated and the OH break contacts open the ringer circuit. The OH make contacts close and the CR make or CO break contacts close, completing the circuit from tip through the OH make contacts, the CR make or CO break contacts, the RU break contacts, and through the hybrid transformer to the ring circuit. Since the set is in an answer condition, the dialer pulsing contacts are not in the circuit.

### "TOUCH-TONE" DIALER CIRCUIT

2.42 The following circuit description applies to ASR and KSR sets only.

2.43 The tone dialer utilizes a transistor oscillator which generates two frequencies each time a pushbutton on the dialer is depressed. The frequencies of oscillation are determined by the values of inductance and capacitance in tank circuits T1-C1 and T2-C2 (3D4-3D6). Different values of L and C are placed into the tank circuits (by the closure of contacts in each circuit) when the pushbuttons are depressed.

2.44 The tone dialer is made operable only when the set is the originate mode and before the call connection between stations is made. The dialer is made operable by making the base of Q1 (3F5) negative with respect to the emitter, causing the transistor to conduct. The circuit path is from ground through the 200 ohm resistor (connected to the CAL rheostat), RV4, RV3, R1, and into the data set at CN41 to -20 v dc.

2.45 In the 101C data set, this path is provided by the CON make-break and M make-break contacts. In the 105A data set, the path is provided by the CO make-break and MO make-break contacts.

2.46 Once the stations are connected, the dialer is disabled to prevent interference caused by its accidental use. It is disabled by opening the circuit between -20 v dc and the collector of Q1. This turns off Q1 and stops the oscillations. The CON break contacts (in the 101C data set) or the CO make contacts (in the 105A data set) open to break the circuit when the stations connect.

2.47 When a tone dialer is used, the speaker amplifier receives two inputs: the normal telephone line input and a tone dialer input. The telephone line signal path is from the incoming amplifier in the data set through CN31 (in the 101C data set) or CN30 (in the 105A data set) through contacts CS (W2-V) to terminal 1 of speaker amplifier input transformer T1 (3F3). The signal from the secondary winding of T1 is fed through contacts CS (Z-Y) and capacitor C1 to the base of input transistor Q1.

2.48 The tone dialer multifrequency output is applied to the base of input transistor Q1 through capacitors C5 and C1. The speaker amplifier output (dial tone) is applied to both the speaker amplifier and the telephone line through the data set. The circuit path to the telephone line is from the emitter of output transistor Q2, through capacitor C3, contacts CS (T-S), and to the outgoing amplifier in the data set at CN47.

2.49 Depressing a pushbutton on the dialer causes common switch CS to operate and its YZ contacts (3D5) to open. This disconnects the signal input from the telephone line to the speaker amplifier. Common switch contacts ST (3D3) close to connect the amplifier output to the telephone line through the outgoing amplifier in the data set. Contacts W2-V open to prevent the dial tone from reaching the incoming amplifier which would cause a false connect. Contacts W1-U (3C6) open and interrupt the dc current in tank coils T1 and T2. Oscillations then start with a very short build-up time.

2.50 Potentiometer CAL (3E4) is used to adjust the level of multifrequency signals generated by the dialer. It must be adjusted each time the data set is changed.

2.51 Capacitor CAN (3E4) and C4 (3F5) suppress spurious signals in the range of 7 k hz to 14 k hz. These signals are generated during the short time interval when all sensing contacts and the E contacts (3B7) are open.

### SPEAKER AMPLIFIER CIRCUIT

2.52 The following circuit description applies to ASR and KSR sets only.

## SECTION 574-100-103TC

2.53 The speaker amplifier is a conventional, direct-coupled, two-transistor audio amplifier. The amplifier may receive two inputs. One input, the frequency-modulated dial signals from the buffer amplifier in the data set limiter circuit, is fed to the primary winding of input transformer T1. (This winding continuously carries the 4 ma quiescent current of the receiving buffer amplifier in the data set). The second input comes from the tone dialer (if used), and is fed directly into the input transistor Q1 through capacitor C5. Both inputs to the speaker amplifier are dc isolated from the amplifier stages.

2.54 The output transistor, Q2, provides outputs from its collector and emitter. The output from the collector of Q2 is applied to the step-down output transformer T2, and then to the speaker and receiver. Potentiometer CF is used to set the proper volume level which may vary with loop loss and the ambient noise level. Dial tone is independent of loop noise.

2.55 The output from the emitter of Q2 is divided into two signal lines. One injects the dial tone into the data set sending amplifier. The second signal line feeds the dial tone detection circuit in the data set (if provided). Signal levels from the emitter of Q2 are essentially independent of the volume control setting.

2.56 Resistor R6, bypassed by capacitor C6, is a supply voltage dropping resistor. Diode CR1 (2E6, 3E6) blocks the sneak path from ground through the ANS and ORIG lamps in the answer mode. Without CR1, the ORIG lamp would be dimly lighted and the speaker amplifier would not be silent when the station is in the answer mode.

2.57 When operating with a 101C data set the speaker amplifier is made operable only during the originate mode. This occurs when the OR (originate) relay operates and its make contacts close, completing the circuit from the emitter of Q2, through the S (send space) break contacts (2E8, 3E8), to ground.

2.58 When operating with a 105A data set the speaker amplifier is made operable only in the originate mode. This occurs when the OR relay operates and its make contacts close, completing the circuit from the emitter of Q2, through the SR (send space) break contacts and the OH (off-hook) make contacts, to ground.

2.59 The speaker amplifier is disabled after the stations connect. This is done by short-circuiting the primary of input transformer T1 through ground by closure of the CON (connect) make contacts (in the 101C data set) or the CO (connect) break contacts (in the 105A data set).

### SIGNAL GENERATOR CIRCUITS

#### A. Signal Line Circuit

2.60 The following circuit description mainly refers to ASR sets. It can be used with KSR sets if all references to the reader are disregarded. It can be used with

RO sets if all references to the reader and keyboard are disregarded.

2.61 The signal line circuit path is from -20 v dc in either the 101C or the 105A data set (4F3). The circuit path goes into the teletypewriter set at CP7, through the distributor, keyboard, reader contacts, and into the data set at CP8.

2.62 Set connected to 101C data set: When the signal generator contacts are closed, current of approximately 0.005 ampere flows from +20 v dc through the 7500 ohm resistor (4F7) to -20 v dc; and a current of approximately 0.008 ampere flows from ground, through the emitter and base of Q1M, to -20 v dc. The current through the contacts is the sum of these two currents, or about 0.013 ampere.

2.63 The voltage across diode CR1M (4F7) is fed to the modulator in the data set. When CR1M conducts, the modulator generates the marking frequency; when the diode is off, the modulator generates the spacing frequency.

2.64 The modulated signal is then fed to the limiter and discriminator for demodulation. Demodulated signals consist of current during marking pulses and no current during spacing pulses. During marking pulses, transistor Q3A (4F4) conducts and provides a circuit from ground through its emitter and collector, through the 249 ohm resistor into the teletypewriter set at CP1. From CP1 the circuit is through the selector magnet drivers, and into the data set at CP2 to -20 v dc.

2.65 Depression of the BREAK key for 140 milliseconds or longer is recognized as a break by the send break timer in the data set. This causes the modulator to originate a timed spacing signal of 225 milliseconds duration.

2.66 The timed spacing signal is recognized as a break (and not a disconnect) by the timer in the data set, which causes the RB (receive break) relay to pull up and close the RB make contacts (4F3). The RB make contacts shunt the transmitter and keyboard signal generator contacts which block transmission from the station. The BRK-RLS pushbutton must be depressed before transmission can be resumed.

2.67 Set connected to 105A data set: From CP8 the circuit path is through the SO or RO make contacts to the base of the modulator keying transistor 4Q3 in the data set. When the signal generator contacts are closed, the base is negative with respect to the emitter and 4Q3 is on. This causes the modulator to generate the marking frequency. When the signal generator contacts are open, transistor 4Q3 is off, and the modulator generates the spacing frequency.

2.68 In half-duplex operation, the circuit also goes into the teletypewriter set at CP2, through the selector magnet driver, into the data set at CP1, and through the discriminator output transistor 6Q10. Demodulated signals consist of current during marking pulses and no current during spacing pulses.

2.69 During marking pulses, transistor 6Q10 conducts and provides a circuit from ground through its emitter and collector, through the 240 ohm resistor, into the teletypewriter set at CP1, to and through the selector magnet drivers, into the data set at CP2, and through the signal generator contacts to -20 v dc.

2.70 The time break signal is generated in the 105A data set as follows: When the set is turned on, the CO (connect – normally operated) relay operates and the timer operates the TM (timer) relay. The TM make contacts (4F8) complete the circuit through the BO (break – normally operated) relay and the CO make contacts to ground. The BO relay operates and is held operated by its make holding contacts and break key contacts when the TM and CO relays release.

2.71 Depressing the BREAK key releases the BO relay, causing the timer in the data set to generate a timed spacing pulse (about 200 milliseconds duration). The BO break contact closes to complete the circuit from +20 v dc through the TM break contacts and BO break contacts, to the base of modulator keying transistor 4Q3. This turns 4Q3 off and causes a spacing pulse to be generated.

2.72 The TM relay operates 200 milliseconds later to interrupt the path from +20 v dc, through the TM and BO break contacts, to the base of 4Q3. The transistor turns on again, and the BO relay operates through the circuit from +20 v dc, through the TM make contacts, the BO relay, and the CY make contacts to ground. The BO relay is held operated by its make holding contacts and the break key contacts when the TM and CO relays release.

2.73 When the CY (copy) relay is released, the selector magnet drivers are held in a ready marking condition as follows.

(a) Operation with a 101C data set: The CY break contacts close to keep discriminator output transistor Q3A conducting to ground.

(b) Operation with a 105A data set: The CY break contacts close to provide a path to ground in parallel with transistor 6Q10. Other CY break contacts short-circuit the signal generator contacts to -20 v dc.

#### B. Signal Generation Circuit

2.74 The following circuit description mainly refers to ASR sets. It can be used with KSR sets if all references to the reader are disregarded. It can be used with

RO sets if all references to the reader and keyboard are disregarded.

2.75 Depressing a key, or operating the reader or answer-back, causes contacts to either open or close a part of the circuit path for each code pulse. The remainder of the circuit path passes through the code segment on the outer ring of the distributor, and through the brush to the inner ring.

2.76 The code pulses will be marking if the circuit path is closed, and spacing if the circuit path is open.

2.77 The path for each pulse through the answer-back contact block are make contacts. Operation of these contacts is determined by the coding of the answer-back drum.

2.78 The path for each pulse through the reader contact block are make contacts. These contacts will remain open until a hole is sensed in the tape. When this condition occurs, the contacts will momentarily close.

2.79 The paths for pulses 1, 2, 3, 4, and 6 through the keyboard contact block are make contacts. The contacts close for each pulse whenever a key is depressed that corresponds to that pulse marking.

2.80 The path for the 5th pulse is determined by transfer and shift transfer contacts. When a key is depressed for a character, the 5th pulse make contacts (4B3) close. This provides a circuit path from KP(5) or KP(2) through shift break and shift make contacts to KP(3).

2.81 When the shift key is depressed in addition to a key for a character which has the 5th pulse marking, the 5th pulse shift break contacts will open. Therefore, no circuit path is provided between KP(5) or KP(2) and KP(3), and the 5th pulse will be spacing.

2.82 When the shift key is depressed in addition to a key for a character which has the 5th pulse spacing, the 5th pulse shift make contacts will close. This will provide a circuit path from KP(5) or KP(2), through shift make and shift break contacts to KP(3), and the 5th pulse will be marking.

2.83 The path for the 7th pulse goes from KP(4) through the KP-V make contacts as follows:

(a) On a nonparity keyboard, the path continues through KP-P, the control break contacts, and KP(3) to KQ-1.

(b) On a parity keyboard, the path continues through KS(2), KS-A, the control break contacts, and KS(1) to KQ-1.

## SECTION 574-100-103TC

2.84 The path for the 8th pulse, through the keyboard contact block on a nonparity keyboard, are make contacts which close so that the 8th pulse is marking for all characters.

2.85 The path for the 8th pulse, through the contact block on parity keyboards, is from KP(2) to KS(1) as follows:

(a) The 8th pulse is spacing for all characters when the sum of the marking pulses in bits 1 through 7 is even. No path is provided between KP(2) and KS(1) since the 8th pulse make contacts connected to KP-J and the shift make contacts connected to KS-C are open.

(b) The 8th pulse is marking for all characters when the sum of the marking pulses in bits 1 through 7 is odd. A path is provided from KP(2) through the 8th pulse make contacts, KP-J, KP-L, KS-D, the shift break contacts, KS(2), KS-A, and the control break contacts to KS(1).

2.86 When the CTRL (control) key is depressed along with a key for a letter character, the control break contacts open so that the 7th pulse is now spacing. This action makes the 6th and 7th pulses alike resulting in a control or nonprint character.

2.87 On a parity keyboard, whenever the SHIFT key is depressed to invert the 5th pulse, or the CTRL key is depressed to change the 7th pulse from marking to spacing, the 8th pulse must be changed to keep the sum of the marking pulses even. This is accomplished in the following manner:

(a) When the SHIFT key is depressed and the 8th pulse is normally marking, the opening of the shift break contacts connected to KS-D changes the 8th pulse to spacing.

(b) When the SHIFT key is depressed and the 8th pulse is normally spacing, the closing of the shift make contacts connected to KS(2) change the 8th pulse to marking. The circuit path is traced from KP(2) through the break contacts KP-K, KP-R, KS-C, shift make contacts, KS(2), KS-A and the control break contacts to KS(1).

(c) When the CTRL (control) key is depressed and the 8th pulse is normally marking, the opening of the control break contacts change the 8th pulse to spacing.

(d) When the CTRL key is depressed and the 8th pulse is normally spacing, the closing of the control break contacts connected to KS(2) changes the 8th pulse to marking.

### C. Control and Shift

2.88 To obtain certain code combinations, the CTRL (control) and shift keys are depressed in addition to some other key. When this is done, the 5th pulse is inverted and the 7th pulse is spacing, but the 8th pulse does not change.

2.89 With the 8th pulse normally marking, the circuit goes from KS(2) through the make contacts, KP-J, KP-L, the shift make contacts, KP(6), KS-B, and the control make contacts to KS(1).

2.90 With the 8th pulse normally spacing, the circuit will be broken since the shift break contacts connected to KP-R and the 8th pulse make contacts are open. The path through KP-R, KS-C, the shift make contacts, KS(2), and KS-A is broken since the control break contacts are open.

### SELECTOR MAGNET DRIVER CIRCUIT

2.91 The selector magnet driver is a two-stage triggering regenerative amplifier or flip-flop, used to drive the selector magnets of the typing unit. The input, 0.020 or 0.060 ampere signal line current, is used to switch the selector magnets 0.500 ampere output current to full on or off, without intermediate levels. This provides a switching operation similar to that obtained with relays.

2.92 Zener diode ZD1 provides a reference voltage of 4.7 volts. This voltage is maintained regardless of varying values of current through ZD1 or with variations in external voltages. Therefore, the junction of CR4 and ZD1 is always -24.7 v dc. (Current flows from -20 v dc through ZD1, CR4 and R8, and through the parallel path of R2 to -40 v dc.)

2.93 The frequency modulated space and mark signals are demodulated and amplified in the data set. Refer to the appropriate sections for a description of the data set discriminator and dc amplifier circuits.

2.94 When spacing pulses are generated, no current flow through the emitter and collector of Q3A (in the 101C data set) or 6Q10 (in the 105A data set). A current of 10 ma flows from -20 v dc through resistor R3, varistor CR5 and the emitter-base path of Q1, and through R1 to -24.7 v dc at the junction of CR4 and ZD1. (When the signal line current is 0.060 ampere and switching at 0.030 ampere is desired, R1 is 135 ohms.) Transistor Q1 is on (base is more negative than emitter) and current flows through its emitter and collector. This puts the base of Q2 at about -20 v dc. The Q2 emitter, because of bias resistor R6, is at about -20.5 v dc. Because the base of Q2 is positive with respect to the emitter, Q2 is off and no current flows through the selector magnet coils.



2.95 When marking pulses are generated, a 0.020 ampere signal current flows from ground at the emitter of transistor Q3A (in the 101C data set) or 6Q10 (in the 105A data set) through the emitter-collector path, resistor R30N or 6R44 in the data set and through resistor R10. (Resistor R10 is strapped out for operation with 0.060 ampere signal current.

2.96 The current through R10 then divides with 0.010 ampere going through resistor R1, diode CR4 and resistor R8, and through the parallel path of resistor R2 to -40 v dc. The base of Q1 is at a potential of about -19.5 v dc while the emitter is at -20 v dc. With the base more positive than its emitter, Q1 is off and has no collector current. The voltage drop across diode CR4 is about 0.5 volt, making the potential at the base of Q2 about -25.2 v dc. With the base more negative than its emitter, Q2 turns on, and its emitter-collector current flows through the selector magnet coils.

2.97 When Q2 conducts, its base is held at about -25.2 v dc by ZD1 and CR4. The current through R3, R4, and R5 is about 0.5 ampere, most of which flows through the selector magnet coils and the collector. Rheostat R3, is adjusted for a selector magnet current of 0.5 ampere. This current is constant because reference diode ZD1 is not affected by voltage variations.

2.98 Feedback in the emitter circuits of Q1 and Q2 is used to provide the circuit transitions with a "snap action." When Q2 turns on, the current through feedback resistor R3 rises rapidly and the voltage across it increases. This drives the emitter of Q1 more negative. Therefore, when Q1 turns off it is because of the increasing collector current of Q2.

2.99 Similarly, when Q2 turns off, the current through R3 decreases and the voltage across it decreases, making the emitter of Q1 more positive. In this way Q1 is driven on when Q2 turns off.

2.100 The transient developed in the collector of Q2 when it is turned off is suppressed by the network consisting of CR3, R9, and C1. Diode CR6, added to recently manufactured circuits, prevents destruction of transistor Q1 by accidental shorting of the case (collector) of Q2 to frame ground.

#### LOCAL AND MOTOR CONTROL CIRCUITS

2.101 The CY (copy) relay (5F3), in the 101C data set, is operated by closure of the CON (connect) relay contacts when the set connects, or by closure of the LCL (local) key contacts 27 and 28. The CY relay releases when the set goes out of the local mode, or when the S (send space) contacts operate on a disconnect.

2.102 The CY relay (5F2), in the 105A data set, is operated by closure of the CR (connect - normally released) contacts when the set connects, or by closure

of the LCL (local) key contacts 27 and 28. The CY relay releases when the set goes out of the local mode or when the SR (send space - normally released) contacts operate on a disconnect.

2.103 In the local mode, the circuit through the CV relay is completed to ground by LCL contacts 25 and 26. Local contacts 29 and 30 close to light the LCL (local) lamp. Using a 101C data set in an originating station, the circuit is completed through the CV relay and OR6 make contacts to ground. If the 101C data set is used in an answering station, the circuit is completed through the AN11 make and OR6 break contacts to ground.

2.104 In a station that uses a 105A data set, the circuit is completed through the CV relay and OH make contacts to ground. This circuit is in effect when a station goes off-hook in either the originate or the answer mode.

#### READER CONTROL CIRCUITS

2.105 The following circuits are applicable to ASR sets only.

2.106 Using a manual reader, the circuit path goes from 48 v ac through the TD trip magnet, RS break contacts, START switch make contacts, RB or RR break contacts, and TD stop break contacts (on sprocket feed printers) to ground.

#### Originate Mode

2.107 Using a 101C data set, the circuit goes through CN-32 and OR6 make contacts to ground. If a 105A data set is used, the circuit path goes through CN-32 and OH make contacts to ground.

#### Answer Mode

2.108 Using a 101C data set, the circuit path goes through CN-32, AN11 make contacts, and OR6 break contacts to ground. If a 105A set is used, the circuit goes through CN-32 and OH make contacts to ground.

#### Local Mode

2.109 In the local mode, the circuit path goes through LCL contacts 25 and 26 to ground using either a 101C or 105A data set.

2.110 With the switch on the reader in the START position, the start contacts close and the TD trip magnet is put into operation. If the reader runs out of tape or if the tape becomes tight, the start contacts will open. This will cause the trip magnet to release and stop the operation of the distributor and reader. When the tape slackens, the contacts will close and normal operation resumes.

## SECTION 574-100-103TC

2.111 The RR or RB (receive break) contacts open when a break signal is received from a local or distant station and cause the TD (timer delay) to stop. Depressing the BRK-RLS (break-release) pushbutton will restart the TD.

2.112 When the TD is transmitting to a slower speed station through a converter and the storage device becomes crowded, a restrain signal is sent out causing the RS (restrain) contacts (5F2) to open. This will stop the TD until the storage device empties itself. The TD will then restart automatically.

2.113 Using an automatic reader, the circuit path goes from 48 v ac through the TD trip magnet, RS break contacts, tight-tape break contacts, TDC3 make contacts, and TD stop break contacts (on sprocket feed printers) to ground.

### Originate Mode

2.114 Using a 101C data set, the circuit path goes through CN-32 and OR make contacts to ground. If a 105A data set is used, the circuit path goes through CN-32 and OH make contacts to ground.

### Answer Mode

2.115 Using a 101C data set, the circuit path goes through CN-32, AN make contacts, and OR break contacts to ground. If a 105A data set is used, the circuit path goes through CN-32 and OH make contacts to ground.

### Local Mode

2.116 In the local mode, the circuit path goes through LCL contacts 25 and 26 to ground using either a 101C or a 105A data set.

2.117 Using an automatic reader, the circuit path goes from 48 v ac through the TDC relay, stop break contacts, tape out break contacts, START switch make contacts or TD call in make contacts, WRU break contacts, and RB or RR break contacts to ground.

### Local Mode

2.118 Using a 101C data set, the circuit path goes through CP-18, CY make contacts, CP-17, out of service break contacts and low paper break contacts to ground. If a 105A data set is used, the circuit path goes through CP-18 and the CY make contacts to ground.

### Originate and Answer Mode

2.119 Using a 101C data set, the circuit path goes through CN-21, CON make contacts, CN-17, to ground and through CP-18, CY make contacts, CP-17, out of

service break contacts, and low paper break contacts to ground. If a 105A data set is used, the circuit path goes through CP-18 and the CY make contacts to ground.

### Originate Mode Only

2.120 The circuit path goes through the stop break contacts tape out break contacts, X-ON make contacts, through CP-10 as follows.

(a) If a 101C data set is used, the circuit path continues through the M break contacts and CON make contacts to ground.

(b) If a 105A data set is used, the circuit path continues through the MO make contacts and CY make contacts to ground.

2.121 If the set is in the originate mode and X-ON is sent from the keyboard or answer-back of either station, the function box mechanisms of both stations will respond. The X-ON contacts at both stations will close momentarily. Since a path to ground is found only in the originate station, only the TD at the originate will turn on.

2.122 The TDC relay is released and the TD stops when any of the following conditions occur:

(a) Switch depressed to STOP position

(b) Tape out

(c) X-OFF code transmitted

(d) WRU code transmitted

(e) Break

(f) Clear or disconnect.

2.123 Using a 105A data set, the TDC holding path in the local mode goes through the CY make contacts directly to ground. The TD is operable in local and out of service modes.

2.124 Using a 101C data set, the TDC holding path in the local mode goes through the CY make contacts, out of service break contacts, and low paper break contacts to ground. Therefore, in the out of service position, no path to ground is supplied and the TD will not start. If the TD is started before going into the out of service position, the TDC1 make contacts will provide a holding path to ground so that the TD can operate after the set is switched into the out of service mode.

2.125 A momentary closure of the TD call in function box contacts (5E6) will operate the TDC relay. The TDC2 make contacts close to provide the holding circuit.

The TD call in function box contacts close whenever the set receives the particular code to which the function box is designed to respond.

2.126 On sprocket feed printers, the PJ make contacts (5B2) close to provide a circuit path to ground through the motor control relay. This prevents the motor from turning off during the feeding of a form.

2.127 The PJ break contacts open to turn off the TD during form feed after the form code is transmitted from the tape. After the form feed is completed, the contacts close and the TD will restart automatically.

2.128 Diode CR6 rectifies the 48 v ac to provide half wave dc for the TDC relay. Resistor RS limits the current through filter capacitor C3.

### ANSWER-BACK CIRCUITS

#### Automatic Answer-Back

2.129 When a station answers a call, the relays in the data set provide a path to ground through the answer-back magnet in the following manner. In the 101C data set, the circuit path goes through the M make and CON make contacts. In the 105A data set, the circuit path goes through the MO break and CY make contacts. The answer-back is mechanically prevented from cycling more than once.

#### Here Is Answer-Back

2.130 The answer-back will cycle once when the HERE IS key is depressed.

#### WRU Answer-Back

2.131 When WRU is sent from the keyboard or tape, the WRU function box mechanism operates at both the sending and receiving stations. The answer-back at the sending station is mechanically prevented from responding, while the WRU function box mechanism trips the answer-back at the receiving station.

2.132 On sets with an automatic reader, a set of contacts is associated with the WRU function box mechanism. These contacts momentarily open when the mechanism senses the WRU code. When the WRU is transmitted from the reader, the WRU break contacts momentarily open the holding circuit through the TDC2 relay. This will release the TDC relay and shut off the TD. The answer-back is then transmitted from a distant station without garbling. If, however, the WRU is sent from the tape of a manual reader, garbling will occur.

### EOT DISCONNECT CIRCUIT

2.133 The following circuit description mainly refers to ASR and KSR sets. It can be used with RO sets if all references to the EOT transmit are disregarded.

2.134 In half-duplex operation, the disconnect sequence is initiated whenever the sending or receiving station transmits the EOT (end of transmission) code. The EOT function box contacts at both stations close momentarily after the EOT code is transmitted.

2.135 The circuit is arranged so that closing the EOT contacts (6E4) completes a circuit only when the demodulated output is marking. This action prevents disconnecting on a break signal received during the transmission of a character. The break signal could cause the character to appear as the EOT code and initiate a disconnect. However, the break signal duration is such that the demodulator output will be spacing at the time the EOT contacts close.

2.136 When traffic is transmitted from tape, the EOT code is usually followed by a DELETE character to prevent the transmission of an extra character before disconnecting.

2.137 Circuit operation using a 101C data set: The circuit path is from -20 v dc through the S relay, the EOT contacts (when closed), and through the collector and emitter of switching transistor Q9N to +20 v dc. When the demodulator output is marking, the base of transistor Q8N is positive with respect to its emitter. (The output of Q3A is ground on marking and -20 v dc on spacing.) Transistor Q8N then conducts and causes the base of Q9N to be negative with respect to the emitter. Transistor Q9N will then also conduct and complete the circuit path from +20 v dc to -20 v dc and through the S relay when the EOT contacts close. The S relay then initiates the disconnect sequence. The SR relay is held operated through its holding contacts.

2.138 Circuit operation using a 105A data set: The circuit path is from -20 v dc through the SR relay, the collector and base of 2Q2, the EOT contacts, and the base and emitter of transistor 2Q6 to ground. Transistor 2Q2 conducts whenever the demodulator output is marking. When the EOT contacts close, if transistor 2Q2 is conducting, the base of transistor 2Q6 will be more negative than the emitter. Transistor 2Q6 will then also conduct and provide a complete circuit path from ground, through its emitter and collector, through the SR relay, to -20 v dc. This operates the SR relay which initiates the disconnect sequence.

### RINGER AND OFF-HOOK CIRCUITS

2.139 Set connected to 101C data set: The initial station line circuit path is from the ring side of the telephone line to the parallel-connected bell, the RU relay, through the AN and OR break contacts, and to the tip side of the telephone line.

2.140 At the originating station, the ORIG (originate) pushbutton is depressed, the OR relay operates, and its transfer contacts break the connection of the bell and RU relay between ring and tip. At stations with a tone dialer (M option), a strap is used in place of the rotary dial

## SECTION 574-100-103TC

contacts. When this action is completed, an off-hook condition is presented to the central office.

2.141 At the answering station, the ac ringing current is received from the central office. If the called station is in the automatic answer mode, the ringing current operates both the bell and the RU relay. The RU relay operates the AN relay, which is held operated by its holding contacts. The AN transfer contacts break the connection of the bell and RU relay and connect the hybrid transformer into the circuit between ring and tip. This action presents an off-hook condition to the central office.

2.142 Set connected to 105A data set: The initial station line circuit path is from the ring side of the telephone line to the parallel-connected bell and RU relay, through the OH break contacts, and to the tip side of the telephone line.

2.143 At the originating station, the ORIG pushbutton is depressed, the OR relay operates and, in turn, operates the OH relay. The OH transfer contacts break the connection of the bell and RU relay, and connects the rotary dial contacts, which are in series with the hybrid transformer, into the circuit between ring and tip. At stations with a tone dialer (M option), a strap is used in place of the rotary dial contacts. When this action is completed, an off-hook condition is presented to the central office.

2.144 At the answering station, the ac ringing current is received from a central office. If the called station is in the automatic answer mode, the ringing current operates both the bell and the RU relay. The RU relay operates the OH relay, which is held operated by its holding contacts. The OH transfer contacts break the connection of the bell and RU relay and connects the hybrid transformer into the circuit between ring and tip. This action presents an off-hook condition to the central office.

### OUT OF SERVICE CIRCUIT

2.145 The following circuit description mainly refers to ASR and KSR sets. It can be used with RO sets if all references to the dialer and speaker amplifier are disregarded.

2.146 The OUT OF SERV (out of service) switch is used to prevent the set from automatically answering incoming calls. The OUT OF SERV lamp is lighted by the closure of contacts 7 and 8 to indicate this condition.

2.147 When the switch is turned to the OUT OF SERV position, the set will respond in one of two ways, depending on the option selected. With the A (don't answer) option, the ringer and RU relay are made inoperative by shorting when contacts 5 and 6 close. With the B (make

busy) option, the ringer and series capacitor are shorted when contacts 5 and 6 close. This makes the station appear to be off-hook or busy to the central office.

2.148 The NL (nonlocking) contacts 1, 2, 3, and 4 of the OUT OF SERV switch are used at terminal hunting stations, where the switch is rotated to the RESTORE position until a dial tone is heard. In this position the contacts do the following:

- (a) Make contacts 3 and 4 short the tip to ring, producing an off-hook condition, which detected by central office. The central office releases the set from lock-out and applies the dial tone.
- (b) Make contacts 1 and 2 apply ground to the speaker amplifier, permitting it to pass the dial tone.

### PAPER ALARM CIRCUIT

2.149 The paper alarm circuit operates an audible alarm (buzzer) and warning lamp to alert the operator when the tape or paper supply is low. In addition, it prevents the set from automatically answering a call during an alarm condition.

2.150 When the typing unit paper supply is low, the low paper switch will operate. On friction feed typing units, this switch will operate when the paper roll decreases to a predetermined diameter. On sprocket feed typing units, the switch will operate when a bail drops through a notch in a form near the end of the supply.

2.151 Operation of any of these switches will close the circuit from 10 v ac to ground by going through the buzzer and the BUZ-RLS (buzzer release) lamp. The buzzer sounds. Depressing the BUZ-RLS pushbutton will turn the buzzer off but the BUZ-RLS lamp will remain on until one of the other pushbuttons is depressed.

2.152 Set connected to 101C data set: The automatic answer circuit path is from -20 v dc through the AN relay, RU make contacts, CY break contacts, out of service switch break contacts and low paper switch break contacts to ground.

2.153 On automatic answer, the RU (ring up) make contacts (8B5) close to operate the AN (answer) relay, which remains operated because of its holding contacts.

2.154 Set connected to 105A data set: The automatic answer circuit path is from +20 v dc through the OH relay, OR break contacts, RU make contacts, CY break contacts, out of service switch break contacts and low paper switch break contacts to ground.

2.155 On automatic answer, the RU (ring up) make contacts (8B6) close to operate the OH (off-hook) relay which remains operated because of its holding contacts.

2.156 The automatic answer is disabled during the following conditions regardless of which data set is used:

- (a) **Set in Local Mode:** In the local mode, the CY relay is operated and its break contacts are open, preventing automatic answer. On an incoming call, the ringer sounds and the ANS lamp flashes. The call may be answered manually by depressing the ANS pushbutton.
- (b) **Low Paper:** The low paper break contacts open, preventing automatic answer from taking place. On an incoming call the ringer will sound and the ANS lamp will flash. The call may be answered manually depressing the ANS pushbutton.
- (c) **Out of Service:** The out of service break contacts open preventing automatic answer from taking place and also disabling the ringer. The ANS lamp will flash on incoming calls. The call may be answered manually by depressing the ANS pushbutton.

#### POWER CIRCUITS

2.157 The following circuit description refers mainly to ASR sets. It can be used with KSR sets if all references to the tape reader and tape punch are disregarded. It can be used with RO sets if all references to the tape reader, tape punch, and the rectifier are disregarded.

2.158 The 115 v ac input supplies the power for the following items:

- (a) Motor
- (b) Selector magnet driver transformer
- (c) Power transformer (10-14-48 v ac)
- (d) Elapsed time indicator
- (e) Rectifier on reader card.

2.159 The elapsed time indicator and motor are operated by the motor control relay make contacts.

2.160 When the TD trip magnet operates it causes the TD feed magnet to energize. The feed magnet raises the reader sensing pins while the distributor transmits the start pulse. If a hole is present in the tape, the code contacts will be closed. If no hole is present in the tape, the code contacts will be open.

2.161 The TD trip magnet remains energized and the sensing pins remain up when the distributor transmits the 8th code pulse. At the end of the 8th code pulse, the

TD feed magnet contacts open causing the magnet to de-energize. This will cause the feed wheel to stop and the sensing pins to retreat.

2.162 When the distributor transmits the start pulse, the TD feed contacts will close and the cycle will be repeated.

#### 3. CIRCUIT SWITCHING SERVICE

3.01 Circuit switching service operates over short and intermediate length telegraph loops using neutral signaling or, over longer loops with polar signaling when modified with proper polar-to-neutral converting circuitry. Within the unit are a power supply circuit, and a motor delay timer circuit.

##### POWER SUPPLY CIRCUIT

3.02 A fused power supply circuit (Figure 1), operates on 117 volts ac  $\pm 10$  percent at 60 hertz  $\pm 1/2$  hertz, and a power input of 12 watts. The power supply ground is floating with respect to the input signal line; that is, it is not at earth ground. Therefore, the center tap of the transformer is  $\pm 120$  volts from earth ground in neutral signaling. The polar adapter, on teletypewriters so equipped, also contains a power supply. This power supply, as well as the one found on the call control unit, uses an earth ground.

##### LOCAL-REMOTE CONTROL CIRCUITS

3.03 The local-remote control consists of three printed circuits placed upon the same circuit card that accomplish the switching called for by the line input or the call control unit pushbuttons. The three circuits are, proceed-to-dial, connect, and local. The circuits are essentially made up of binaries (flip-flops) that have been modified to perform certain functions. All three circuits are protected with a diode arc suppressor against transients and voltage pulses generated by their associated relays.

3.04 A negative voltage, generated at the collector of a transistor will be shorted through the diode to resistor R27. The transient will be developed across R27 and the lamp associated with the relay. The diodes that suppress the transients in each circuit are C10, C12, and C19. The circuits are also protected from transient noise induced into them from leads in the cable to the dial and key and lamp assembly. A low-pass filter or delay network of the RC type is placed in a feedback loop in each binary. These delay networks are made up of R10 and C3, R21 and C4, and R39 and C11.

3.05 The signal line inputs are filtered against spurious noise occurring on the signal line. There are two of these RC type filters. In the proceed-to-dial circuit, R5 and C1 provide a 0.001 second delay while, R12 and C2 provide a

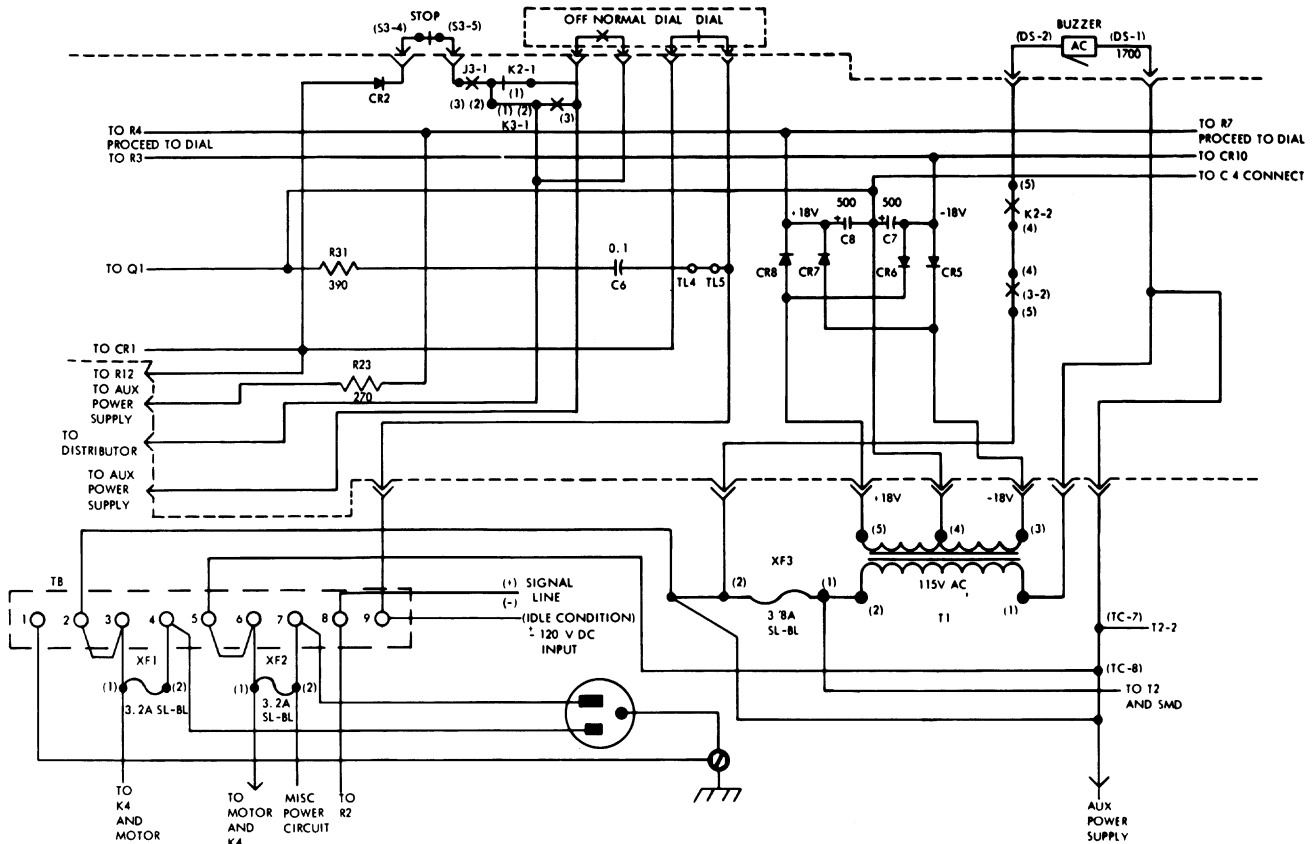

Figure 1 - Power Supply Circuit

0.02 second delay in the connect circuit. The network consisting of R31 and C6 found in the 240 volt signal line, acts as an arc suppressor to protect its associated contacts. This network may be removed from the signal line by removing the strap between terminals TL4 and TL5. Additional network components may be added to these terminals, if required.

A. Proceed-to-Dial Circuit

3.06 The proceed-to-dial circuit (Figure 2), consists of a binary with a line input amplifier. The amplifier consists of transistor Q1 and its associated components, and the binary consists of transistors Q2 and Q3 along with their associated components. The amplifier is connected to the binary through a low-pass filter delay network (R5 and C1) which suppresses signal line noise. The input to the binary, coming from the filter network and passing through R6, will turn on the proceed-to-dial circuit. Control inputs through R15 and the stop pushbutton contacts 1 and 2, are used to turn off the circuit. Operation of the transistors in the proceed-to-dial circuit is as follows:

(a) When transistor Q2 is in conduction, its collector is very near a neutral potential. Current will flow through Q2, R11, stop pushbutton contacts 1 and 2, and R27. Current will also flow from +18 volts through R8 and CR9 to the collector of Q2. The base of Q3 will be held at +0.8 volts with respect to the collector of Q2 due to the current flow of CR9. The base of Q3 will therefore, be slightly positive with respect to neutral, and Q3 will be turned off. With Q3 off, its collector will be negative and Q2 will be held in conduction. This is accomplished by applying current to the base of Q2 supplied through the low-pass filter made up of R9, R10, and C3.

(b) When transistor Q3 is in conduction, the proceed-to-dial circuit will be on and the collector of Q3 will be very near neutral. Current will flow through Q3, K1, the dial lamp, and R27. Since the collector of Q3 is near neutral, current flow through R7, R9, and R10 will produce a positive potential at the base of Q2. This positive potential will hold Q2 off. With Q2 held off, base current for Q3 will flow through CR9, R11, stop pushbutton contacts 1 and 2, and R27. This flow of current will hold Q3 in conduction.

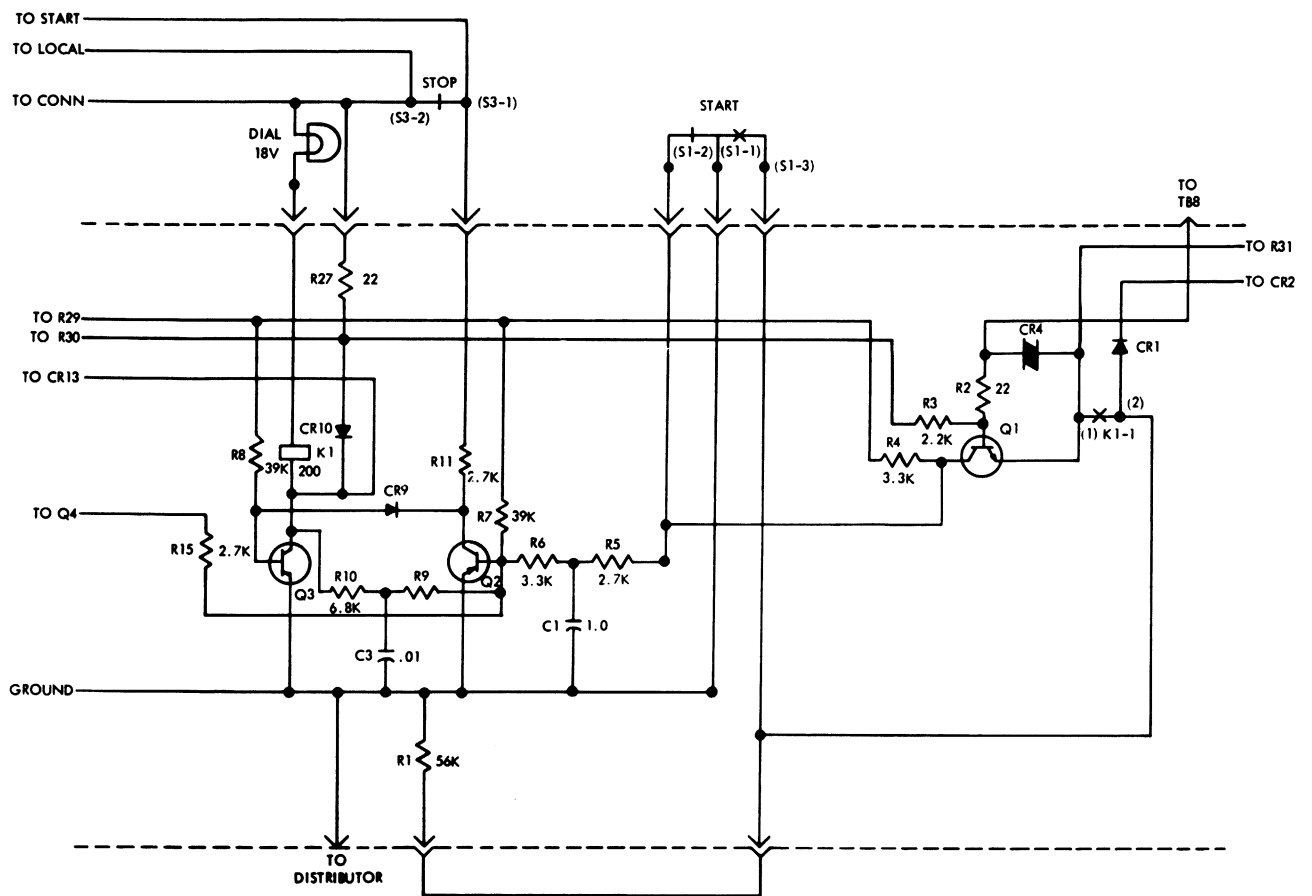

Figure 2 - Proceed-to-Dial Circuit

(c) If an input current in excess of 0.009 ampere flows from TB-8 across CR4 to neutral, a positive potential of 0.8 volts will be developed across CR4. This positive potential will hold Q1 in conduction and its collector near neutral. The neutral condition has no effect upon the base of Q2 because of the isolation provided by R5 and R6. If the input current falls below 0.009 ampere, a negative potential of 0.8 volts is developed across CR4 due to current flow through R3, R2, and CR4. This potential will turn off Q1 and its collector becomes positive. Current now flows through R4 and R5 to charge C1 towards a +18 volts. When a sufficient voltage is developed across C1, the base of Q2 will be back-biased through R6. Transistor Q2 turns off and Q3 turns on placing the proceed-to-dial circuit in the on condition. Back-bias to the base of Q2 is supplied by the voltage divider R7, R9, and R10 so that the positive potential across R6 is no longer required to hold Q2 off. If more than 0.009 ampere begins to flow across CR4 again, Q1 will turn on, and its collector will go to neutral, but this will have no effect on the base of Q2.

(d) If a negative signal is applied to the side of R15 opposite the base of Q2, enough current will flow to forward-bias the base of Q2 and cause it to conduct. Q3 will turn off and supply sufficient base current through R9 and R10 to hold Q2 in conduction. The negative signal on R15 can now be removed, and Q2 will remain in conduction.

(e) With the proceed-to-dial circuit on, Q3 will be in conduction. Base current for Q3 will flow through R11 and CR9. Depressing the STOP pushbutton causes contacts 1 and 2 to open breaking the current path. Transistor Q3 will then turn off and Q2 will turn on. There will be no collector current flowing in Q2; therefore, the collector will be near neutral holding Q3 off. When the STOP pushbutton is released, collector will flow in Q2 and the proceed-to-dial circuit will turn off.

#### B. Connect Circuit

3.07 The connect circuit (Figure 3) consists of a binary (Q4 and Q6) of which one side is driven by emitter follower Q5. The only control input to this circuit is by the

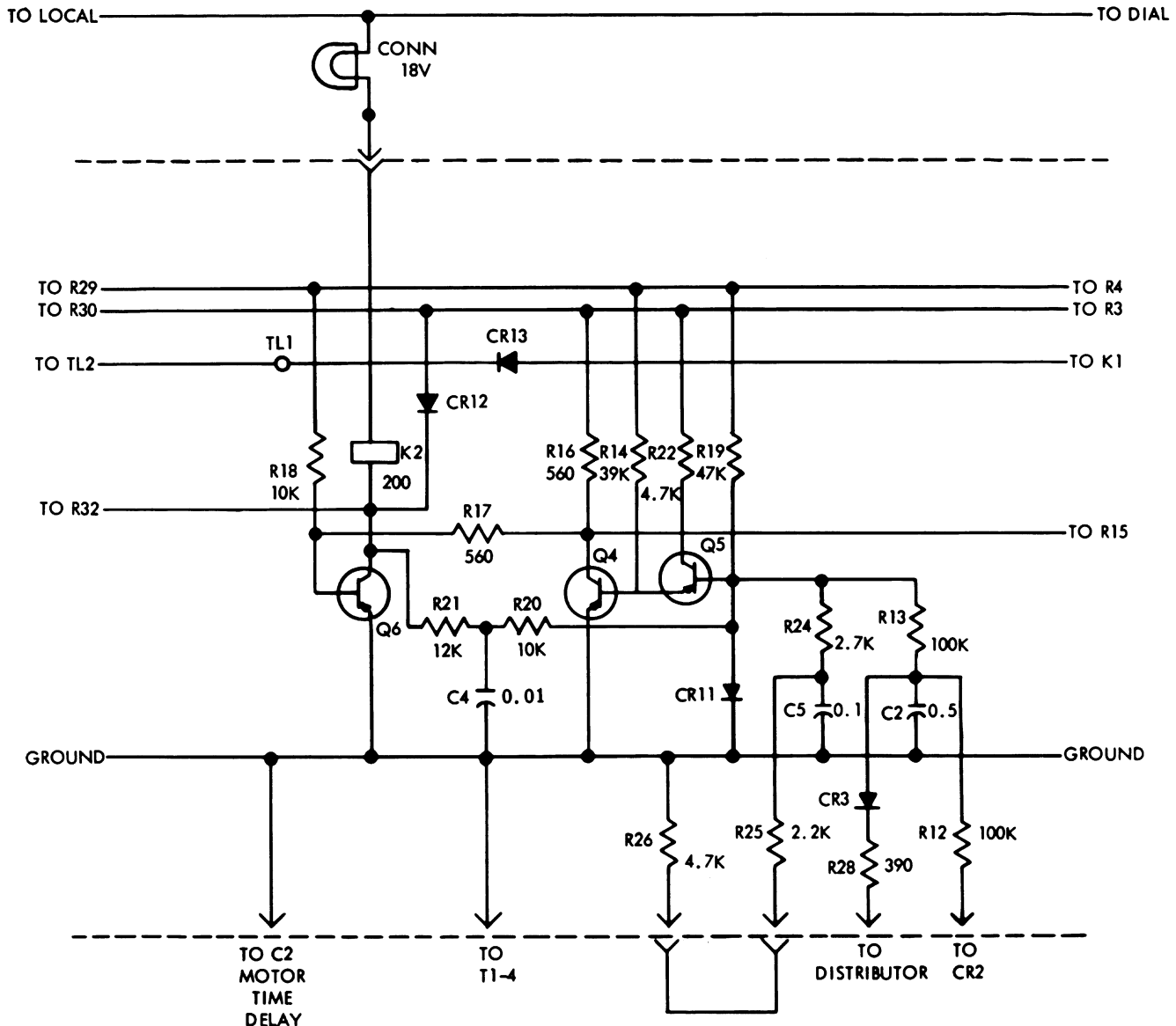

Figure 3 - Connect Circuit

signal line through R12 and R13. A signal delay of approximately 0.02 seconds is provided by the low-pass filter network consisting of C2 and R12. A single passive control, consisting of R28 and CR3, is used for low-paper conditions.

(a) Transistor Q5 controls the base of Q4. When transistor Q4 is in conduction, its collector is very near a neutral potential. A voltage divider consisting of R17 and R18 hold the base of Q6 positive so that Q6 is off. This will make the collector of Q6 go negative and also make the base of Q5 go negative by the current path through R20 and R21. Since Q5 is an emitter follower, its emitter will be held at the same potential as its base. With its emitter at a negative potential, Q4 will be held on.

(b) When the connect circuit is on, Q6 will be in conduction and its collector will be near a neutral potential. The voltage divider R19, R20, and R21 holds the base of Q5 and therefore the emitter, at a positive potential. With the emitter of Q5 at a positive potential, the base of Q4 will be reverse-biased, the transistor will be off, and its collector will go negative. The connect circuit will be held on by the base for Q6 that flows through R16 and R17.

(c) To control the connect circuit a high voltage must be developed at the junction of CR1 and CR2 (circuit card TP305689). This voltage will be approximately  $\pm 200$  volts. If a  $\pm 200$  volt signal is applied at this point, the base of Q5 will be biased positive. Q4 will



turn off and Q6 will turn on. If a -200 volt signal is applied, the base of Q5 will be biased negative, Q4 will turn on and Q6 will turn off. An input signal at or near a neutral potential will have no effect upon the connect circuit, and it will remain in its prior state.

(d) The base of Q5 is protected against excessively high voltages by transistor operation or by CR11. If a -200 volt signal is present, the voltage on the base of Q5 will go in a negative direction and force its emitter to follow. When the emitter of Q5 becomes negative with respect to ground, Q4 will turn on. With Q4 in conduction, the potential on its base will be close to the emitter. Therefore, the base cannot go more negative than -0.4 volts. This action will hold the base voltage of Q4 to within -0.4 volts of its emitter. Therefore, the base voltage of Q5 cannot become more negative than -0.8 volts. If a +200 volt signal is present at the input, the base of Q5 will start to become positive. The diode CR11 is forward-biased to positive base voltages. It will, therefore, limit the base voltage of Q5 to +0.8 volts. Therefore, under the severest input conditions, a voltage swing of more than  $\pm 0.8$  volts is not expected.

(e) Resistors R24, R25, R26 and capacitor C5 are used where a polar converter is employed. They are shown all connected together and have no effect upon the operation of this circuit.

### C. Local Circuit

3.08 The local circuit (Figure 4), consists of a binary and a unijunction transistor timer. The binary operation of Q8 and Q9 is the same as that described in the proceed-to-dial circuit. Four input controls are available for use with the local circuit.

(a) Operation of the LOCAL pushbutton allows transistor Q9 to go into conduction and also turn the local circuit on. When contacts 1 and 2 are closed, base current will be supplied to Q9 through R37 and R38 causing Q9 to turn on and Q8 to turn off. If the anode of either CR13 and CR14 is neutral, the current flowing through R38 will flow through one of these diodes and not reach the base of Q9. These two diodes allow the local circuit to be turned on only when the proceed-to-dial and the connect circuits are off.

(b) The local circuit can be turned off by depressing either the START or the STOP pushbutton. When the local circuit is on, the base current of Q9 flows through start contacts 4 and 5 and stop contacts 1 and 2. Since the contacts of the two pushbuttons are in series, operating either of them will turn Q9 off. The output of unijunction transistor Q7, will also turn off the local circuit as it is basically a breakdown device.

(c) If the voltage on C9 is more negative than approximately -8 volts, the resistance of the junction between the lead connected to C9 and the lead connected to R35 is high. When the voltage on C9 becomes more positive than -8 volts, the resistance of this junction will become very low, and C9 will recharge through R35. The increase in current flowing through R35, while recharging C9, will cause an increase in the voltage drop R35. The positive pulse is coupled through C10 and CR17 to the base of Q9 and causes it to turn off and Q8 to turn on. The local circuit is then off. As capacitor C9 is recharged, the resistance of the junction again becomes high.

(d) Capacitor C9 is discharged toward neutral or held at about -18 volts through R32 and R33. If the input to R32 is negative (connect circuit off), C9 will be held at -18 volts. If the input to R32 is near neutral (connect circuit on), capacitor C9 will discharge through R32 and R33 toward neutral. At the end of a 2.3 second interval, the voltage on C9 will be approximately -8 volts and the unijunction will break down and turn the local circuit off as described above.

### MOTOR DELAY TIMER CIRCUIT

3.09 The motor delay timer circuit (Figure 5), provides the means to delay motor turn-off in the teletypewriter. This allows the teletypewriter to complete its printing cycle and come to rest before the motor begins to stop. This circuit, along with the selector magnet driver circuit, are mounted on the same circuit card but are electronically independent of each other. The circuit is designed to drive a motor control relay connected between points 3 and 5 and is operated when either the connect or local circuit is on.

3.10 The motor delay timer consists of a regenerative switch (Q3 and Q4) and an output driver (Q2). The input to the motor delay timer is from the collector of Q9 through diode CR16 or from the collector of Q6 through diode CR15 in the local and connect circuits of the local-remote control circuit. The diodes provide insulation between the input of the motor delay timer and the transistors of the local-remote control for negative signals. When the input of the motor delay timer at point 2 is grounded, the output driver will turn on immediately. When the input signal is removed, the output driver will remain in conduction for 0.55 seconds while holding the motor relay operated long enough to allow the teletypewriter to complete its printer cycle before turning off the motor.

3.11 When a negative input signal is applied to point 2, base current to Q3 will flow through R13, R15, and R14. Q4 will be held in conduction by the base current flowing through R12 and R16. The collector of Q3 will be close to -1.6 volts. The voltage divider R12 and R16, will hold the base of Q2 positive and therefore Q2 will be cut off.

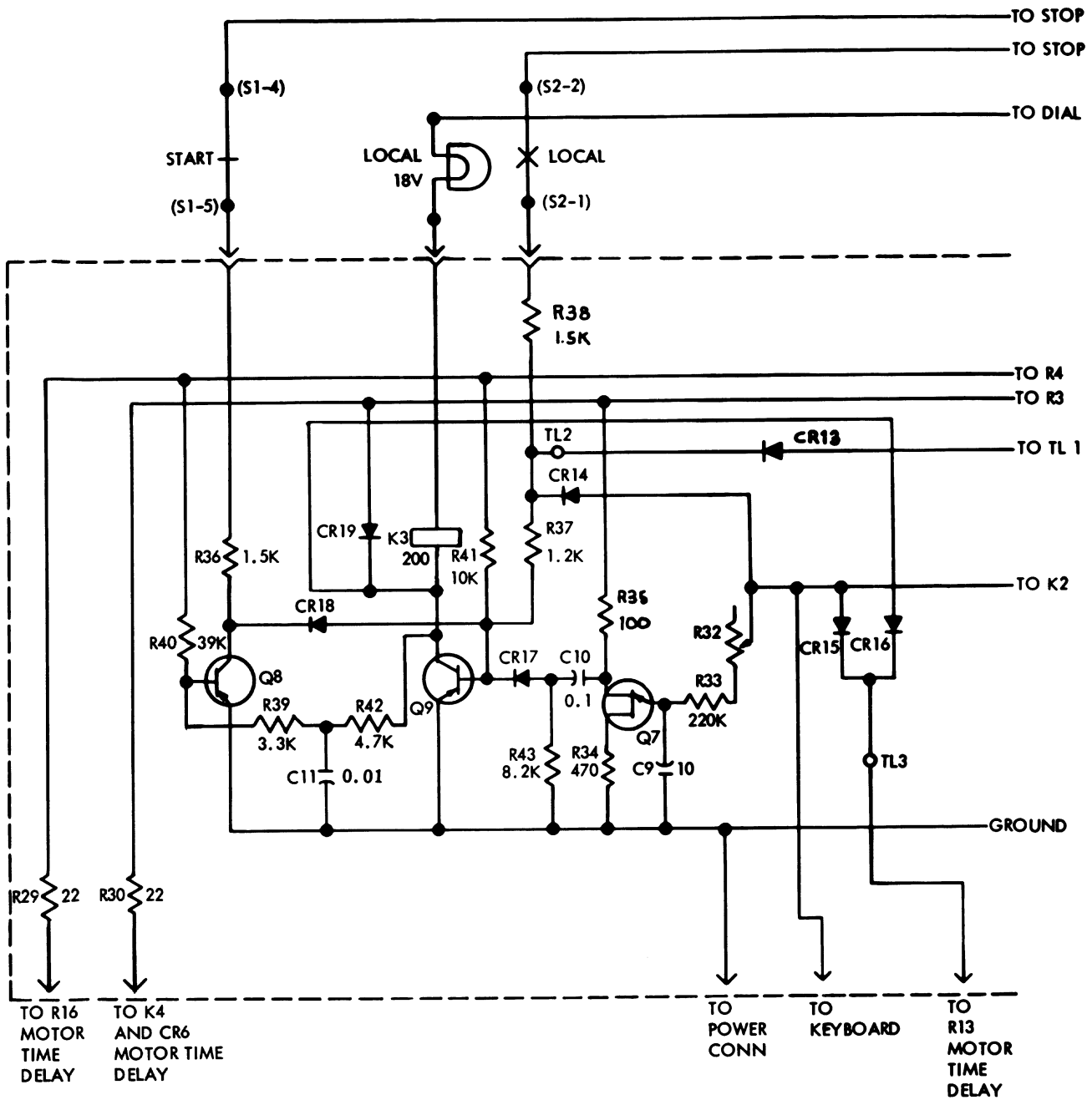

Figure 4 - Local Circuit

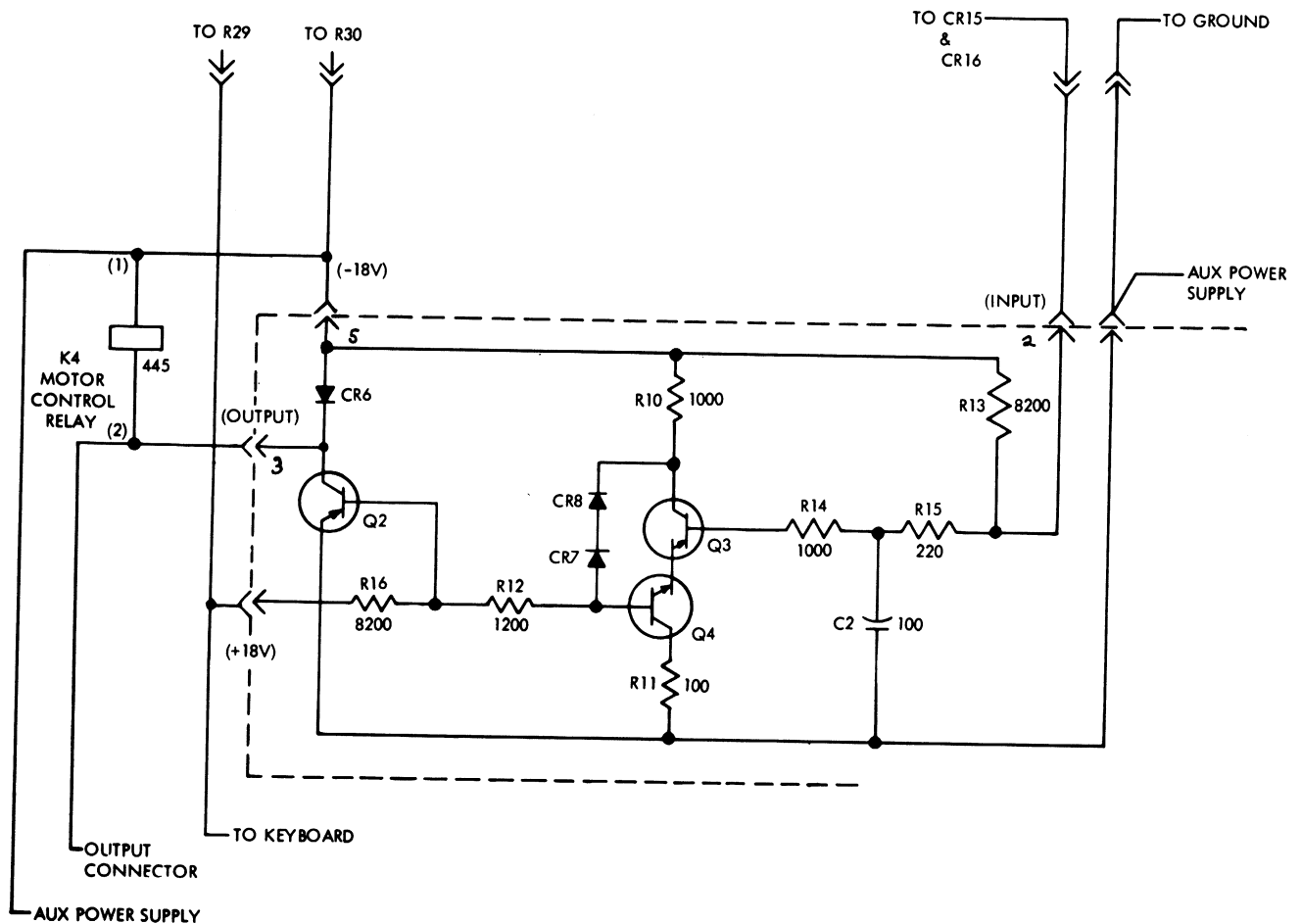

Figure 5 - Motor Delay Timer Circuit

3.12 If ground is now applied to the input, the base of Q3 will approach ground and become reverse-biased. This will turn Q3 off. The collector of Q3 will now be at a potential of -10 volts. This voltage will cause the voltage at the base and emitter of Q4 to be at a potential of -8.5 volts. The emitter of Q3 will be held at -8.5 volts by the emitter of Q4. This will hold Q3 off. The -10 volt potential at the collector of Q3 will cause base current to flow to Q2 through CR7, CR8, and R12. Q2 will then go into conduction, and operate the external motor control relay.

3.13 If the ground input is now removed, current will flow through R13 and R15 and charge C2 toward -18 volts. After about 0.55 seconds the voltage on C2 will reach -8.5 volts and Q3 will go into conduction with its collector going less negative. This causes the base of Q4 and, therefore, the emitter of Q3 and Q4, to become less negative. This process will continue until both Q3 and Q4 are saturated. C2 will then discharge through R11 and the base of Q3 to ground. Base current to hold Q3 in conduction is supplied through R13, R15, and R14.

3.14 At 25 degrees C, with a 390 load, the delay of the motor timer is from 0.475 second to 0.675 second when the supply voltages are within 3 percent of their nominal values.

#### SELECTOR MAGNET DRIVER CIRCUIT

3.15 The selector magnet driver circuit (Figure 6), combined with an external power transformer, and a filter capacitor, provides 0.500 ampere current for driving the selector magnet from a telegraph signal source of appropriate input line current. The input signals are applied through terminals 6 and 11, with R1 determining the switching level.

3.16 For a mark input, a positive current is applied to terminal 11. This will provide a positive bias to the base of transistor Q1 that overcomes the normal negative bias supplied through R1 and stabilized by zener diode ZD1. Q1 will turn off as the increasing positive current reaches one-half of its final value. The collector of Q1 then goes

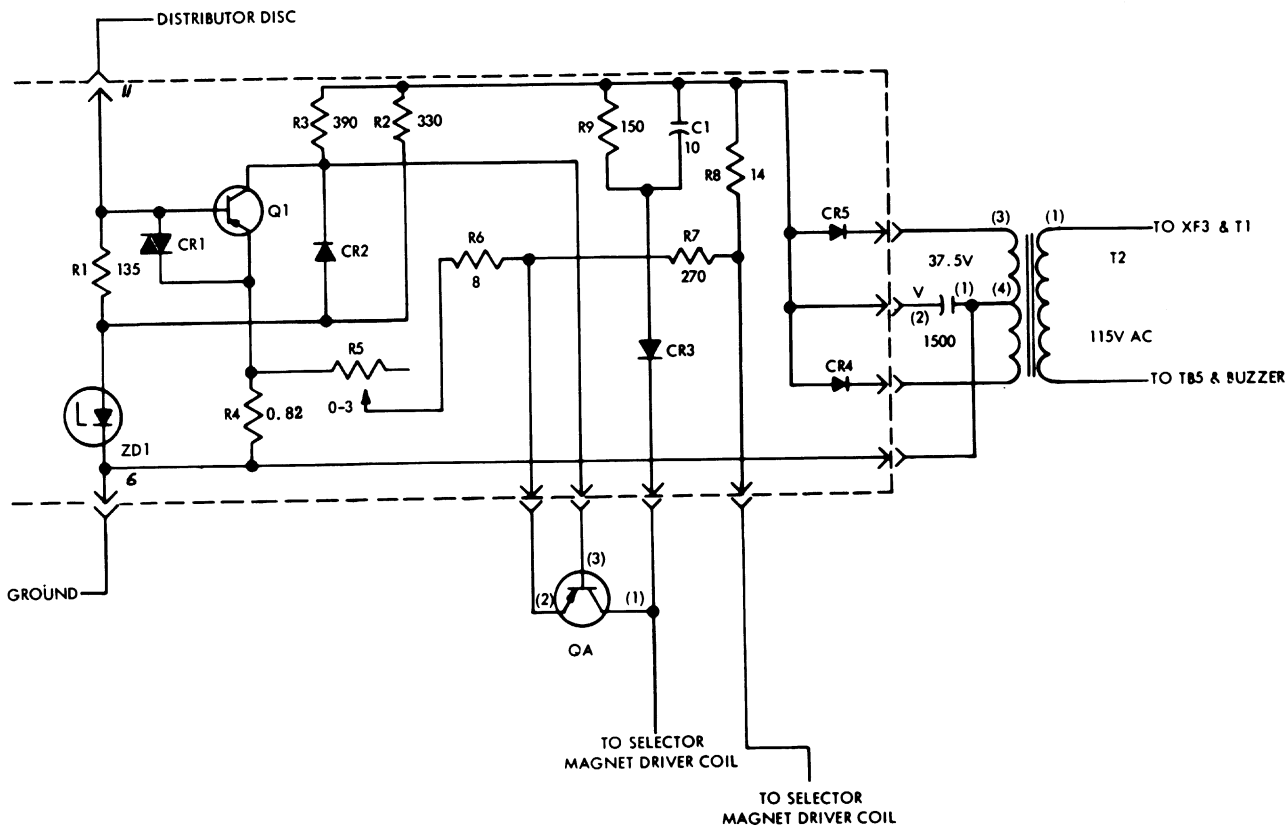

Figure 6 - Selector Magnet Driver Circuit

negative and this negative potential is applied to the base of QA and turns QA on. R4 will provide emitter bias to Q1, and supplies a regenerative action to the transistor.

3.17 The selector magnet is connected between the collector of QA and the junction of R7 and R8, and supplies the load for QA. On marks, the current rises to 0.500 ampere and energizes the selector magnet. On spaces, the positive input bias decreases, and Q1 is turned on at the half-line current point by negative bias through R1. The collector of Q1 rises towards a zero potential, applying reverse-bias to QA, turning off QA, and de-energizing the selector magnet. The selector magnet opposes the change in current, and it applies a transient potential to the collector of QA. CR3 will now conduct and pass the transient potential to C1 and R5 which limits the potential to a value well under the breakdown voltage QA while selector magnet energy is being dissipated.

## NEUTRAL SIGNALING

### A. Circuit Interconnections

3.18 The block diagram for the circuit interconnections is shown in Figure 7.

### Proceed-to-Dial

3.19 In order to turn on the proceed-to-dial circuit, two conditions must be satisfied: The START pushbutton must be depressed and the proper line signal must be received from the exchange. The START pushbutton presents the proper signal to the exchange so that the request to dial is recognized. It also protects the circuit from an open line and long line breaks such as those generated when dialing.

3.20 The proceed-to-dial circuit can be turned off in two ways: By the depression of the STOP pushbutton or by the operation of the connect circuit. Local control is provided by the STOP pushbutton while the connect circuit provides automatic control initiated by the exchange.

3.21 The connect circuit is controlled only by the line and, therefore, has only one input which comes from line sensing and control.

### Local Circuit

3.22 To turn on the local circuit, the following conditions must be satisfied:

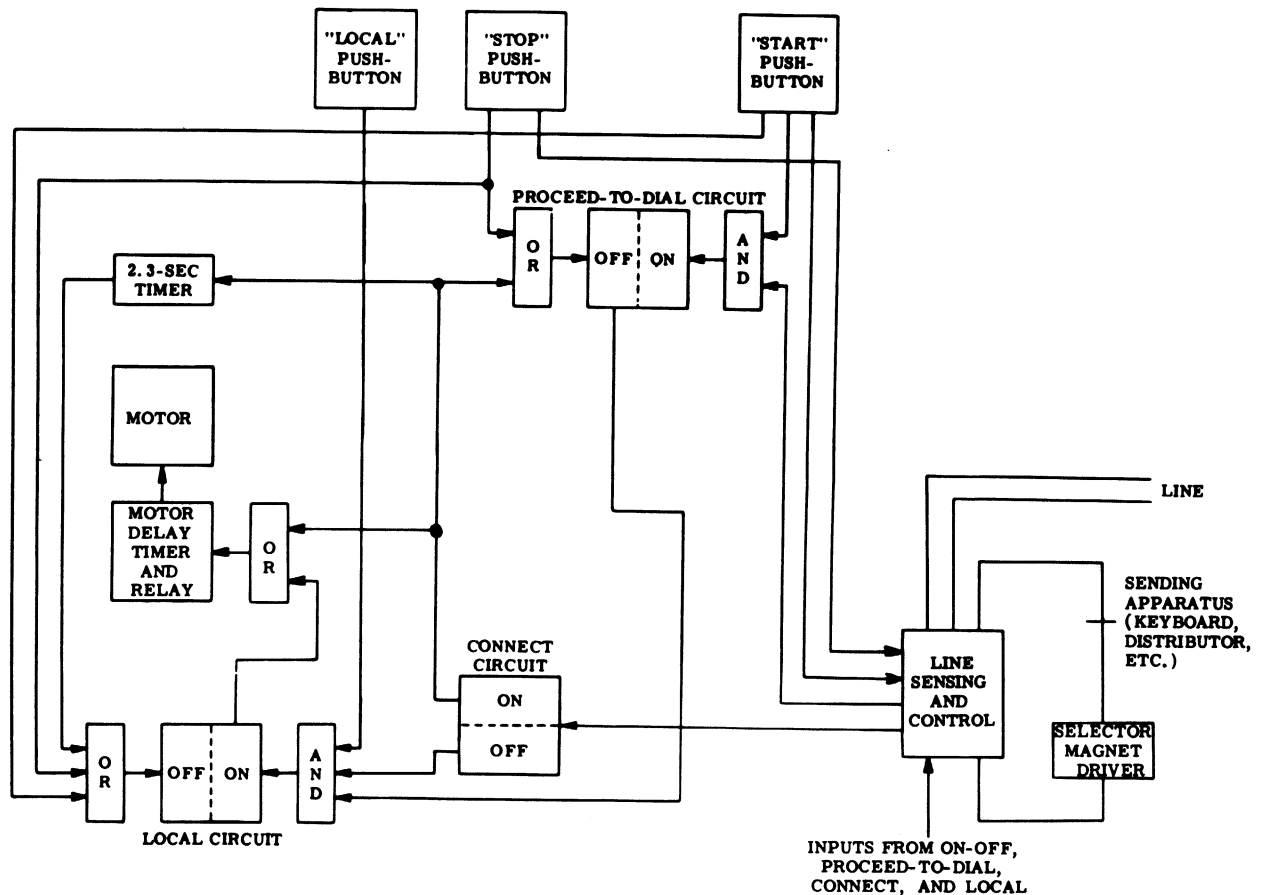

Figure 7 - Circuit Interconnections

- (a) The proceed-to-dial and the connect circuits must be off, and the LOCAL pushbutton must be depressed.
- (b) The input of both the proceed-to-dial and the connect circuit protect against the accidental operation of the local circuit which would otherwise cause an automatic disconnect.
- 3.23 The local circuit is turned off by depressing the STOP pushbutton, the START pushbutton, or the 2.3-second timer. The START and STOP pushbuttons provide local control of the circuit, while the 2.3-second timer provides the automatic control. The timer is controlled by the connect circuit which is, in turn, controlled by the line. The timer will continue to oscillate as long as the connect circuit is on although only the first timing pulse is required to turn off the local circuit.
- 3.24 Each of the circuits mentioned has an input to the line sensing and control. The inputs are in the form of relay contacts which switch the line through the proper internal path in the local and remote control assembly. When

either the connect or local circuit is on, a motor control relay is operated. The contacts of the relay are used to turn on the motor of the associated typing unit.

#### B. Idle Line Conditions

3.25 The schematic diagram of the local-remote control circuit (Figure 8) shows the current flow during the idle line condition. In this state, all relays and lamps are off. This requires that transistors Q3, Q6, and Q9 be off and that Q2, Q4, and Q8 be in conduction. The output transistor of the motor delay timer is off, and the selector magnet driver is marking.

3.26 The signal loop is a 240-volt source with 4000 ohms in series. In the idle condition the local-remote control offers 43,800 ohms of local resistance to the signal loop. The flow of loop current in this condition is shown in Figure 8. Current flows from TB8, the positive idle terminal, across CR4, through R1 and CR1 in parallel with the base emitter junction of Q4 and Q5, R13 and R12. From this point, current flows through the dial pulse contacts to terminal TB9.

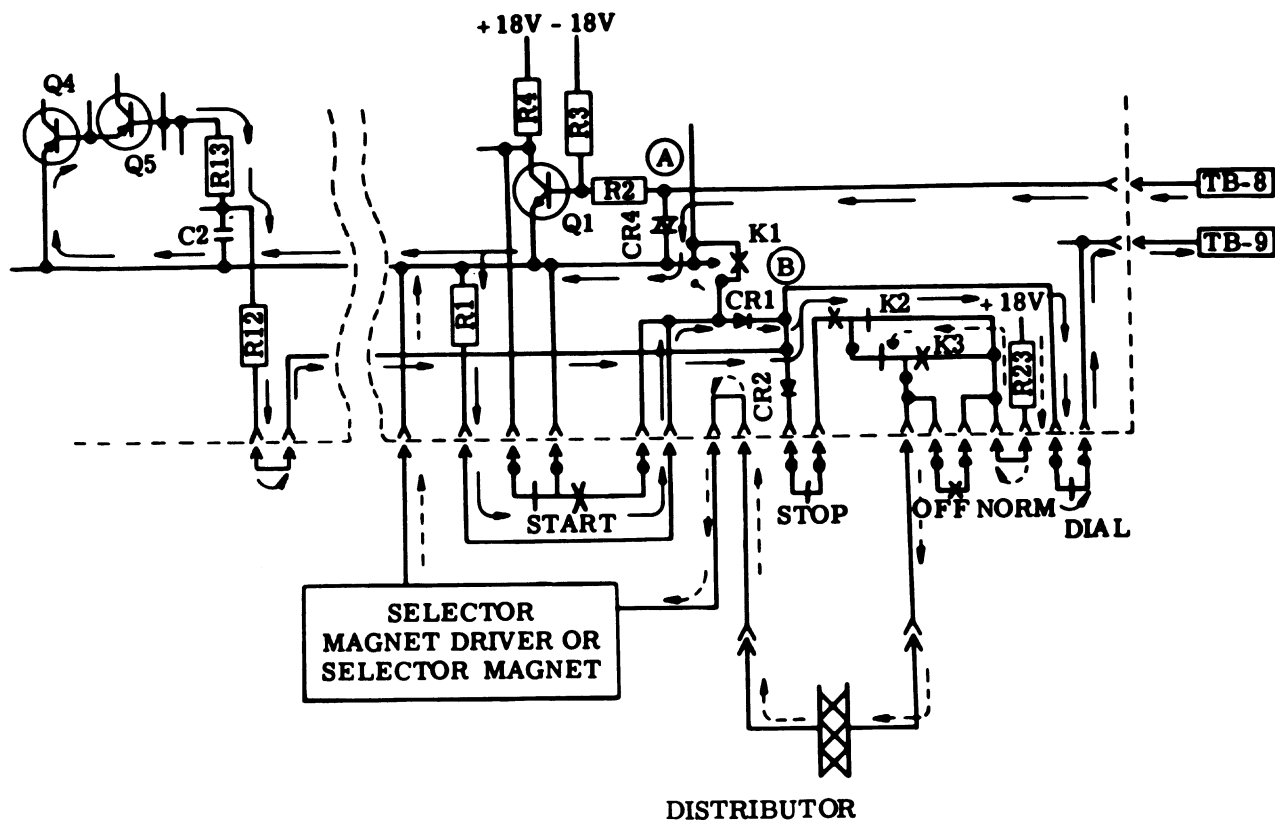

Figure 8 - Local-Remote Control Circuit - Current Flow (Idle)

3.27 The loop current develops a positive potential at A in Figure 8 holding Q1 on. The collector of Q1 is shorted to ground through START pushbutton contacts 1 and 2. Therefore, no signal may be developed at the collector unless the START pushbutton is depressed. The loop current develops approximately a -200 volt potential at point B. This potential will hold Q4 in conduction while holding Q6 and the connect circuit off.

3.28 To locally hold the selector magnet driver and the distributor at neutral, a 0.060 ampere current is supplied through R23 and flows through K2 relay contacts 1 and 2, and K3 relay contacts 1 and 2.

#### C. Initiating a Call

3.29 A call can be initiated with the teletypewriter in either the idle or local condition by depressing the START pushbutton. This performs three functions: Contacts 4 and 5 open to turn off the local circuit; contacts 1, 2, and 3 operate shorting the local loop resistance, allowing the loop current to rise to 0.060 ampere; contacts 1 and 2 open to remove the short from the collector of Q1. The collector will remain at ground since more than 0.002 ampere is flowing through C4. The loop current now flows from TB8, through CR4, START pushbutton contacts, CR1, and the dial impulse contacts to TB9. Shorting out the local loop

resistance causes the voltage at point A to rise to neutral. This action has no effect on the state of the connect circuit.

(a) Proceed-to-dial: When the START pushbutton is depressed, a proceed-to-dial pulse will cause the collector of Q1 to go positive and, in turn, operate the proceed-to-dial circuit (turn Q3 on). With Q3 in conduction, current will flow through relay K1 and the DIAL lamp. This causes both of them to be operated. The normally open contacts 1 and 2 of the K1 relay will operate and short the START pushbutton contacts 1 and 3. Loop current now flows from TB8, through CR4, K1 relay contacts 1 and 2, CR1, and the dial pulse contacts to terminal TB9.

(1) With Q3 in conduction, its collector will be near neutral, CR13 will be forward-biased, and depending on the strapping of TL1, 2, and 3, will either hold the junction of R37 and R38 in the local circuit near neutral and, therefore, preventing the operation of the local circuit or will cause the motor to start.

(2) The proceed-to-dial circuit may be turned off by depressing the STOP pushbutton. STOP contacts 1 and 2 will open causing Q3 to turn off

and the unit to revert to the idle line condition. The current loop is shown in Figure 8.

(3) If the START pushbutton is released any time before the proceed-to-dial pulse is given by the exchange, the unit will revert back to the idle line condition. The START pushbutton should not be reoperated for a few seconds as the exchange requires a short time to reset after this condition.

(b) Dialing: The dial is in the signal loop at all times, but it may be used to transmit information to the exchange only during the proceed-to-dial and the connect conditions. Since the dial impulse contacts are in series with the loop, operation of the dial will completely break loop current. In order to prevent damage to the dial contacts, an arc suppressor consisting of R31 and C6, is placed across the contacts. Terminal lugs TL4 and 5 are provided so that this network can easily be connected or disconnected or so that additional network components can be placed in series with R31 and C6 as needed.

D. Connection

3.30 The schematic diagram of the local remote control circuit (Figure 9) shows the current flow during the local connection.

3.31 Local Connection: If a call is initiated locally, current in the loop will be 0.060 ampere from TB8 to TB9 through the path described in 3.28 before connection. When the loop polarity is reversed by the exchange, current will flow from TB9 to TB8. Diode CR1 becomes reverse-biased and stops current flow except through R12 and R13. This current flow will turn off Q4 and turn on Q6. With Q6 in conduction, the connect circuit will be on, the K2 relay will operate and the CONN (connect) lamp will light. The contacts of the K2 relay will switch and allow the loop current of 0.060 ampere to flow through the distributor and selector magnet driver as shown in Figure 9. Loop current now flows from TB9, through the dial pulse contacts, CR2, K2 relay contacts 2 and 3, K3 relay contacts 1 and 2, the keyboard distributor, the selector magnet driver, and CR4 to TB8.

3.32 With Q6 in conduction, CR15 will be forward-biased and turn on the output transistor of the motor delay timer. The K4 motor control relay will operate by closing its contacts and turning on the printer motor. Q4 will now be cut off and its collector will go negative. Feedback from the collector of Q4 to the base of Q2 through R15 will turn off the proceed-to-dial circuit. The K1 relay contacts will open and the dial lamp will go out. This will have no effect upon loop current flow since these contacts are not now in the current loop. The junction of R37 and

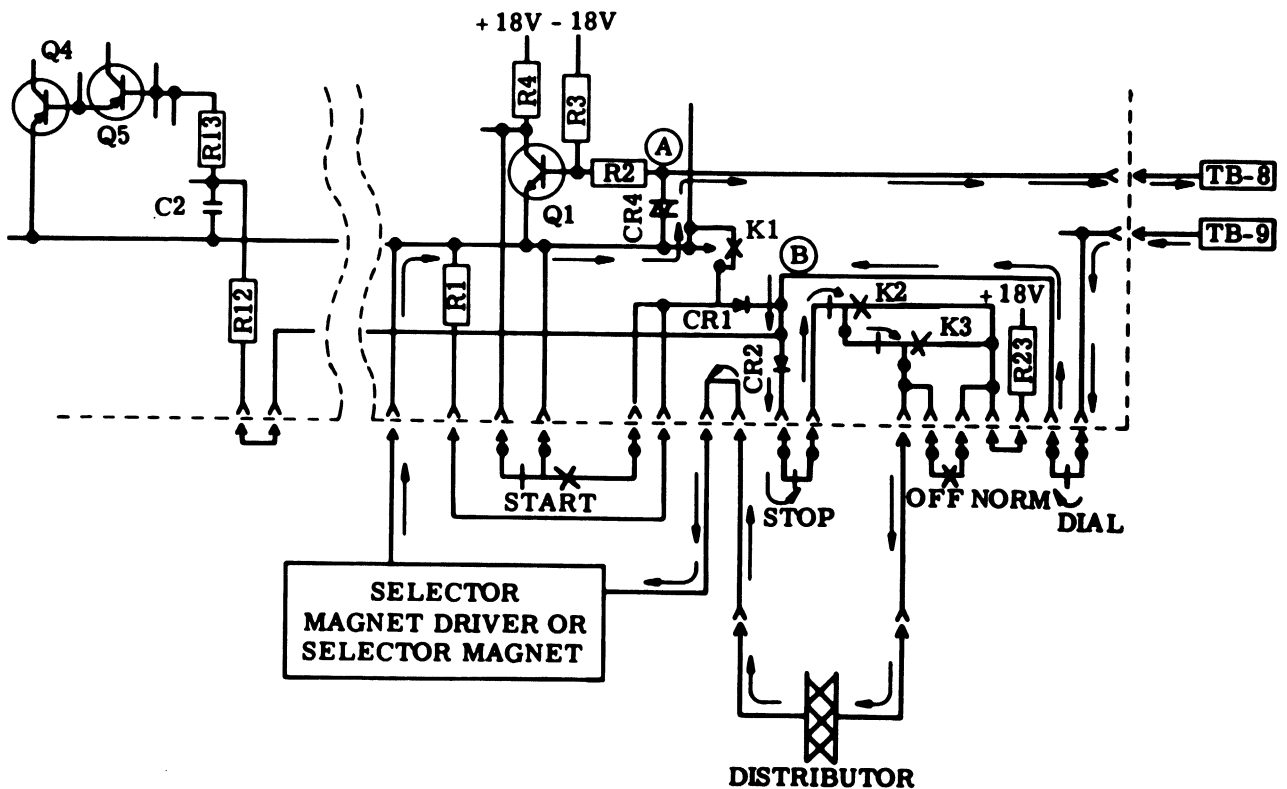

Figure 9 - Local-Remote Control Circuit – Current Flow (Local Connection)

R38 is held near neutral from the collector of Q6 through CR14. This will prevent operation of the local circuit.

**3.33 Remote Connection:** On an incoming call, the teletypewriter may be connected remotely while in the idle line or local conditions. The loop path is shown in Figure 8 for both of these conditions. The incoming call causes the exchange to reverse the loop polarity. This causes the potential at the junction of CR1 and CR2 to change from -200 volts to approximately +200 volts. The potential causes the connect circuit to operate as described in 3.32

**3.34 Low-Paper Circuit:** If the paper in a teletypewriter has become low and the low-paper contacts operate, the junction of R12 and R13 will not be allowed to become positive. Q4 cannot be turned off, and a connection cannot be made. If low paper occurs during a call, the teletypewriter will remain in the connected state, since zero potential at the junction of R12 and R13 will not effect the connect circuit. A disconnect will occur in the normal manner, since CR3 will be reverse-biased to a negative potential at the junction of R12 and R13. If a call is initiated locally with a low-paper condition, the normal sequence of events will occur until a connection is attempted. When the exchange cannot connect, it will reverse the loop polarity, and the teletypewriter will return to the idle state.

#### E. Disconnect

**3.35 Local Disconnect:** Operation of the STOP pushbutton while in the connect condition opens contacts 4 and 5 which are in series with the loop, and breaks the loop. When the exchange recognizes the break, it reverses the loop polarity. The reverse polarity is blocked by CR2, and current flows through CR1 along the path shown in Figure 8. At point A a -200 volt potential is developed due to the current flow described in 3.26 through 3.28. This potential causes the connect circuit to turn off and the teletypewriter stops running open. The input to the motor delay timer becomes negative, and the timer will time out. After 0.55 second the motor control relay releases, and the motor will turn off.

**3.36 Remote Disconnect:** The operation of the circuits and the loop paths are the same as those described in 3.33. The STOP pushbutton is not operated locally, but the signal conditions appear identical to the local-remote control.

#### F. Local Off-Line Operation

**3.37** When the teletypewriter is in the idle line condition, depressing the LOCAL pushbutton will cause the local circuit to turn on. If the control is in the proceed-to-dial or connect conditions, either CR13 or CR14 will prevent operation of the local circuit. When the local circuit does operate, the LOCAL lamp will light. K3 relay

contacts 2 and 3 will short out K2 relay contacts 1 and 2 located in the keyboard selector magnet driver loop. Current in this loop will then flow through R23, K3 relay contacts 2 and 3, the keyboard, and the selector magnet driver to neutral. CR16 will be forward-biased causing the output transistor of the motor delay timer to turn on. The motor control relay will operate and the motor will start. The teletypewriter is now ready for off line operation. To return to the idle position, the STOP pushbutton should be depressed. STOP pushbutton contacts 1 and 2 open and turn off the local circuit. A call may be initiated in the usual manner. When the START pushbutton is depressed, its contacts 4 and 5 open and turn off the local circuit the same way as if the STOP pushbutton were used.

(a) If an incoming call is received while the teletypewriter is in the local condition, the action of the circuit is the same as that described in 3.30 through 3.32. The K2 relay operates to shunt the line through the keyboard distributor and selector magnet driver, but this operation cannot be accomplished since the K3 relay contacts 2 and 3 have shorted the K2 relay contacts 1 and 2 out of the circuit. Operation of the K3 relay contacts 4 and 5 will complete the 115 v ac circuit to the buzzer causing it to sound.

(b) With the connect circuit on, the collector of Q6 will be near neutral. This causes the timer to start. At the end of a 2.3 second period, a positive pulse from the timer is coupled to the base of Q9 through C10 and CR17. This pulse will cause the local circuit to turn off. The LOCAL lamp will go out and K3 will release. The K3 contacts 1 and 2 will short the signal loop through the keyboard distributor and selector. The K3 relay contacts 4 and 5 will open and the buzzer will turn off. The teletypewriter is now in the connect condition.

#### POLAR ADAPTER

##### A. General

**3.38** The following description is based upon schematic wiring diagram 5923WD.

**3.39** The polar adapter converts the types of signals received from the receiving leg and the teletypewriter into those usable by the circuitry and the sending leg. Some of the functions of the relay contacts are modified by the polar adapter, but they serve the same general purpose. The outward operations of the call control unit, with the polar adapter attached, are identical to those of the call control unit alone.

**3.40** The polar adapter consists electrically of four basic parts. These parts are:

(a) Receiving polar relay: This relay converts the received signals into those usable by the circuitry of the adapter and the call control unit.



- (b) Sending polar relay: This relay converts the make-break signals generated by the distributor into transmitted line signals.
- (c) Connect control timer: This circuit is made up of four basic parts and differentiates between control and information signals.
- (d) Current amplifier: This circuit amplifies the signals of the receiving polar relay to control the selector magnet driver.

3.41 The polar adapter operates on a 3-wire basis. Two of these wires are the sending and receiving legs. The third wire is an earth return for these two legs. The polar adapter will, therefore, not operate unless earth ground is supplied. The chassis of the polar adapter is grounded to the power supply. When installed in the call control unit, electrical connection is made through the chassis contact to the third wire in the power plug. This third wire in the power cord must be connected to a suitable earth ground.

3.42 The sending and receiving polar relays are of the nonbridging mercury-wetted contact type. They are housed in metal cylinders with an 11-pin tube socket at their base. Because of the mercury in the relay capsule, they must be operated within 30 degrees of vertical to prevent shorting of the contacts.

- (a) The coils of the polar relay are as follows:

Pins no. 2 and 11 - Drive coil  
Pins no. 3 and 10 - Drive coil  
Pins no. 5 and 9 - Bias coil  
Pins no. 6 and 8 - Bias coil  
Pins no. 1 and 7 - Contacts  
Pin no. 4 - Tongue

- (b) In the polar adapter, contact no. 7 has been chosen as the spacing contact and contact no. 1 as the marking contact. To close contact no. 1 and the tongue, current must flow from either pins no. 2 to 11, 3 to 10, 9 to 5, or 8 to 6.

3.43 All polar relay contacts are protected by arc suppressors. These arc suppressors slow the rate of change of voltage across the mercury-wetted contacts of the polar relays. On the receiving polar relay the arc suppressors are made up of R32, R33, C5, and C6. On the sending polar relay they are made up of R43, R44, C7, and C8.

3.44 All voltage sources are isolated by at least 120 ohms. In the event of a momentary short, current through the polar relay contacts or the connectors is limited to 1 ampere or less. If a short is of long duration, the resistor will act like a fuse and open the shorted circuit. These resistors are R34, R36, R38, R41, and R42.

3.45 When polar signals are being transmitted by the sending polar relay, a noise suppressor is used in the sending leg. This suppressor consists of a "pi" filter and is made up of C11A, C11B, and R45. The filter rejects all high frequency components of the transmitted signal. It is not used when neutral signals are transmitted.

#### B. Receiving Polar Relay

3.46 This polar relay and its associated components convert incoming signals into those usable by the circuitry of the polar adapter and the call control unit.

3.47 Several types of input signals to this polar relay are possible. These modes of operation may be selected by appropriate strapping of the binding posts on the TP181607 printed card assembly. The various modes of operation are:

- (a) Polar signals, battery supplied remotely. This is the normal mode of operation, and all polar adapters are supplied with strapping for this type of operation.
- (b) Neutral signals, battery supplied by the polar adapter. In this condition, posts no. 3 and 4, 5 and 7, and 12 and 13 are strapped together.
- (c) Neutral signals, battery supplied remotely (battery negative). In this condition, posts no. 5 and 12, 6 and 13, and 3 and 4 are strapped together.
- (d) Neutral signals, battery supplied remotely (battery positive). In this condition, posts no. 3 and 4, 12 and 13, and 5 and 6 are strapped together.

3.48 With the wiring as described in 3.47, a spacing signal will cause the tongue (4) of the polar relay to rest on the space contact (7). With a marking signal, the tongue will rest on the mark contact (1). The tongue (4) of the polar relay is supplied with +120 volts through R34. It supplies this voltage to the selected contact, while the other contact has no potential applied. Both contacts have two outputs. One of these is a voltage or direct output, while the other is current output. The current output is through a diode and a resistor and will supply approximately 0.010 ampere to ground. The diode prevents reversed currents from flowing when the contact is not supplied with +120 volts from the tongue. The output diodes and resistors are CR11, CR12, R30, and R31.

3.49 The bias for this relay, when used in neutral operation, is 0.030 ampere and is supplied through R37 and strapped terminals no. 3 and 4. Operating current for neutral operation, when supplied locally, is supplied from -120 volts and is limited to 0.060 ampere by R46 and the signal line resistance.

C. Sending Polar Relay

3.50 This polar relay converts the neutral make-break signal generated by the distributor and the dial into those required on the sending leg. There are a variety of possible signal types that can be transmitted. These are:

- (a) Polar signals, battery supplied by the polar adapter. This is the normal mode of operation and all polar adapters are supplied with strapping for this type of operation.
- (b) Neutral signals, battery supplied by the polar adapter. In this condition, posts no. 10 and 11 are strapped together, and the straps between posts no. 8 and 9, 14 and 15, and 16 and 17 are cut.
- (c) Neutral signals, battery supplied remotely. In this condition posts no. 6 and 10 are strapped together, and straps between posts no. 8 and 9, 10 and 11, 14 and 15, and 16 and 17 are cut.
- (d) Since both the drive and bias windings are wired in series, both windings are supplied with the same amount of current. The input current of 0.021 ampere to the drive windings is supplied through R40 from +120 volts. The 0.021 ampere to the bias is supplied through R39 from +120 volts.

D. Connect Control Timer

3.51 This circuit consists of four basic parts on the TP181606 assembly. These are: a strobe pulse generator, two timing transmission gates, and binary.

3.52 The strobe pulse generator generates a 120 Hz square wave. This square wave and the outputs from the receiving polar relay are used as inputs to the two timing transmission gates. The outputs of these two gates are used to control the binary. The output of the binary, in turn, is used to control the connect circuit in the call control unit.

3.53 The strobe pulse generator is made up of Q1 and Q2 and associated components. It is controlled and caused to oscillate by alternating current from the power transformer of the call control unit. This 12.5-volt ac (18-volt peak) sine wave is rectified by CR1 and CR2 to form a negative 120 Hz wave. The base of Q1 is biased by R2 and R3 such that -3.9 volts is necessary at the junction of CR1 and CR2 to turn on Q1. When base current does flow to Q1, it will turn on, and its collector will become nearly ground. R4 and R5 form a voltage divider which back-biases the base of Q2 and holds it off. The voltage at the collector of Q2 will be set by a voltage divider made up of R8 and R9. This voltage is -9.1 volts. Feedback, through R6 from the collector of Q2 to the base of Q1, will help provide snap-action.

3.54 When the 120 Hz sine wave becomes more positive than -3.9 volts, base current to Q1 will cease to flow. The collector of Q1 will now have a potential of -5.7 volts. Current will now flow through R5 to the base of Q2 and cause the transistor to turn on. The collector of Q2 will now be very close to a neutral potential. This circuit will continue to oscillate as long as power is applied to the control unit transformer.

3.55 Two, 1-percent tolerance resistors (R8 and R9) in the collector of Q2, set the voltage at that point at -9.1 volts. This voltage level is important in controlling the binary and setting the proper time delay intervals in the timing gates. The square wave generated at the collector of Q2 will be ground for approximately 0.0013 second and -9.1 volts for approximately 0.007 second.

3.56 When spacing signal is present on the receiving leg, +120 volts is applied to contact no. 7 and no voltage is applied to contact no. 1 of the receiving polar relay. No voltage will appear across R28, and the voltage at the junction of R28 and R26 is set by current flow through CR10 and R26. This voltage will be approximately -60 volts. CR8 will conduct and the voltage across C3 and at the anode of CR5 will be held at -60 volts. If Q4 is in conduction, its base will be nearly ground, and CR5 will be back-biased by 60 volts.

3.57 The 9.1 volt strobe pulse introduced at C1 will cause the voltage at the anode of CR5 to rise to -50.9 volts. The negative pulse, that follows in 0.0013 second will lower it to -60 volts. The net result of these strobe pulses upon the voltage on C3 is, therefore, zero, and CR5 is not forward-biased at this time.

3.58 When a marking signal appears on the receiving leg, a positive potential of 120 is applied to one side of R28 through the marking contacts of the receiving polar relay. The voltage divider of R26 and R28 will have a +22 volt potential at its junction and reverse-bias CR8. This action will isolate C3 from R26 and R28 and it will begin to discharge through R20 from a -60 volt potential toward ground. The anode voltage of CR5 will respond to the discharging, reducing its reverse-bias condition. After approximately 0.08 second the voltage on C3, and therefore the anode of CR5, will have risen to -9.1 volts. The next strobe pulse to appear at C1 will cause CR5 to become forward-biased, and part of the pulse will appear at the base of Q4.

3.59 The gate just described is the connect timing gate and produces a signal delay of approximately 0.08 second. The disconnect timing gate operates in a similar manner. The input to R27 is from the spacing contact. When mark appears on the receiving leg, R25 and CR9 hold the voltage on C4 at -60 volts. When a spacing signal appears, CR7 will be back-biased, and C4 will discharge through R19

from -60 volts toward ground. In approximately 1.3 seconds the voltage across C4, and therefore at the anode of CR4, will become more positive than -9.1 volts. The next strobe pulse introduced across C2 will cause CR4 to be forward-biased, and part of the strobe pulse will appear at the base of Q3.

3.60 C3 will recharge to -60 volts from -9.1 volts in 0.004 second. C4 will recharge in 0.01 second. Both of these recharge times are less than one code element length and can be considered instantaneous.

3.61 The outputs of the transmission gates control the binary which is made up of Q3 and Q4 and associated components. The operation of this binary is similar to that of the binaries in the call control unit. The control of the binary by the transmission gates is the same as that of the 2.3-second timer controlling the local circuit in the call control unit. A positive pulse at the base of Q4, through CR5, will turn off Q4 and turn on Q3. The collector of Q3 will then be near ground. Current will flow through R35 and through ZD1 to the collector of Q3. The cathode of

ZD1 will be +9.1 volts with respect to its anode, so that the voltage at the cathode will be +9.1 volts. This point is the output to the connect circuit of the call control unit.

3.62 A positive pulse at the base of Q3 through CR4 will turn off Q3 and turn on Q4. The collector of Q3 will go negative. Current flow through CR6 and R23 will hold this voltage to -18 volts. Current flow through R35 and ZD1 will hold the voltage at the cathode of ZD1 to +9.1 volts of -18 volts. The output will then be -8.9 volts. A negative output (Q3 off) will hold the connect circuit of the call control unit off, and a positive output (Q3 on) will hold the connect circuit on.

E. Current Amplifier

3.63 This circuit is made up of Q5 and associated components on the TP181606 assembly. Base current to this amplifier is supplied through CR12 and R31 from the marking contact of the receiving polar relay.

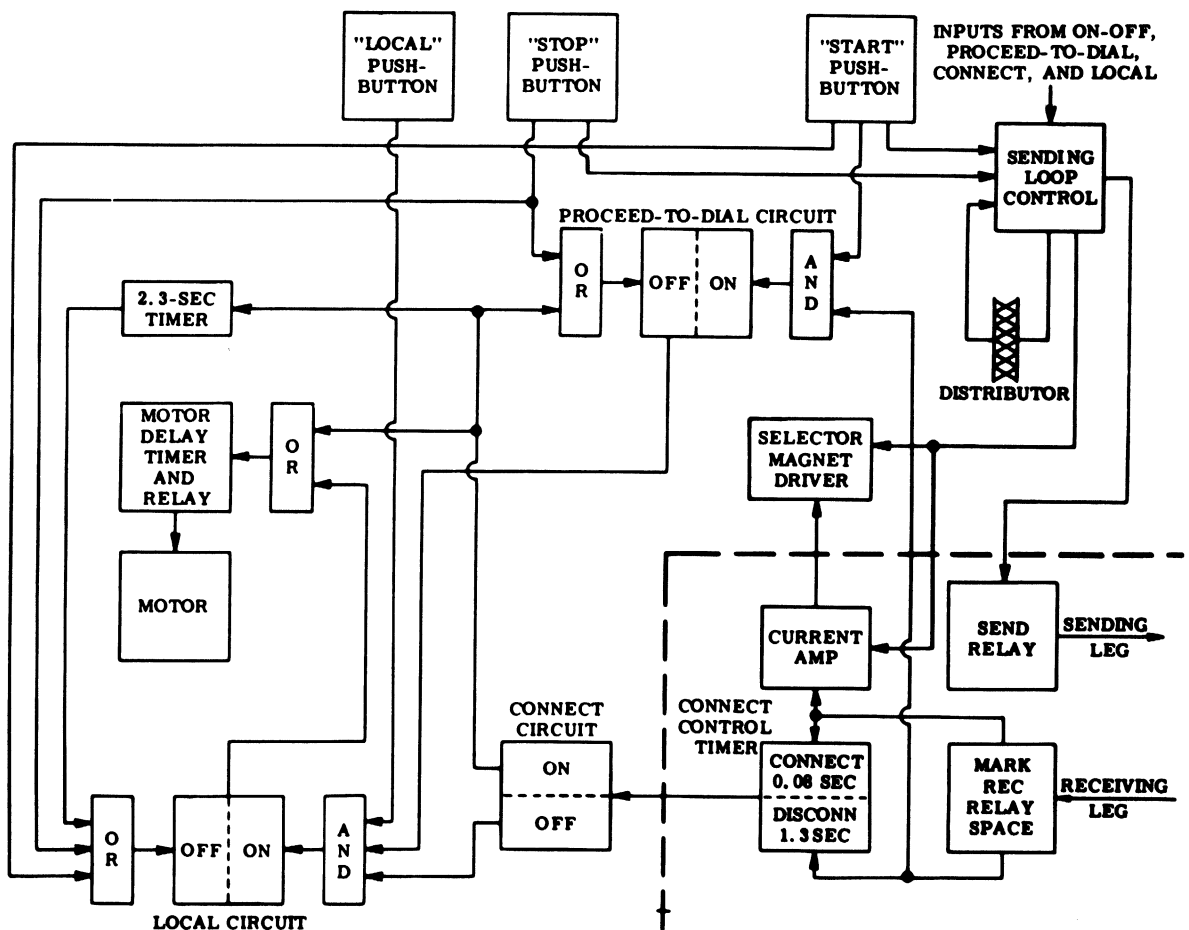

Figure 10 - Polar Adapter Circuit

3.64 If ground is applied to the emitter of Q5 through CR3 or by strapping binding posts no. 1 and 2, the base is reverse-biased by the voltage divider made up of R13 and R14. If base current is now supplied, the transistor will turn on. With the collector load as shown in Figure 12, 0.060 ampere of collector current will flow.

3.65 If the ground to the emitter of Q5 through CR3 is switched to +120 volts, CR3 will become back-biased. The emitter is biased to near +18 volts through R12. Since both the emitter and collector are biased to +18 volts, no current will flow between them. Base current supplied to the transistor will flow into both the collector and emitter. The current in the collector will flow from the base, through the collector, the selector magnet driver, and R23 to +18 volts. This current flow is in the reverse direction of the normal control current for the selector magnet drive, and it will be held spacing.

3.66 The amplifier will supply marking current only when ground is applied to the emitter, and the base current is supplied. If either of these conditions is not fulfilled, the selector magnet driver will not be supplied input current, and its output will be spacing.

3.67 Strapping posts no. 1 and 2 will permanently apply ground to the emitter and allow duplex operation of the teletypewriter.

#### F. Circuit Interconnections

3.68 Figure 10 is a block diagram showing the polar adapter connected to the call control unit. The call control unit portion of the block diagram is the same as that shown in Figure 7 with one exception. The line sensing and control block of the call control unit is now called the sending loop control. All of the components are identical in these two blocks, but rewiring allows the block to control the sending leg rather than the signal loop. This block also has outputs to the current amplifier and the selector magnet driver. The input to the current amplifier allows the teletypewriter to read its own copy. The input directly to the selector magnet driver is for teletypewriter blinding.

3.69 The receiving polar relay marking contact supplies inputs to both the connect control timer and the current amplifier. The input to the current amplifier allows the teletypewriter to read incoming copy. The input to the connect control timer allows the polar adapter to recognize a connect signal. The spacing contact supplies inputs to both the connect control timer and the proceed-to-dial circuit of the call control unit. The input to the connect control timer allows the polar adapter to recognize a disconnect signal. The input to the proceed-to-dial circuit supplies current for spacing signals and no current for mark. This allows this circuit to operate in the normal manner.

#### G. Idle Line Condition

3.70 In this condition both the sending and receiving legs are spacing. All the circuits in the call control unit are off. The spacing contact of the receiving polar relay is +120 volts and allows C4 to be discharged. CR4 will then allow strobe pulses to pass to the base of Q3 and hold it off. The output of the connect control timer is then negative and holds the connect circuit in the call control unit off.

3.71 Figure 11 is a schematic wiring diagram of the sending loop control circuit with the current amplifier and the sending polar relay. Blinding current to the selector magnet driver flows from +18 volts through R23, J5-2, the selector magnet driver, J4-3, and "hl" contact, the "wl" contact, J4-9, and the distributor to ground. No current flows in the drive coils of the sending polar relay, since neither the start contact, the "a" contact, nor the "hl" contact are operated to supply ground.

3.72 The marking contact of the receiving polar relay has no voltage applied. No base current will then flow from this contact to Q5. The emitter of Q5 is biased to +18 volts through R12. The cathode of CR3 is at +120 volts which is supplied through R39 and the sending relay coils, and CR3 is back-biased.

#### H. Initiating a Call

3.73 A call may be initiated when the call control unit is in either the idle line or local conditions as described earlier. Depressing the START pushbutton will allow current to flow through the drive coils of the sending polar relay. This sending polar relay will then transmit a marking signal on the sending leg. The current path through the coils is shown by the dotted line in Figure 11.

3.74 Operating the START pushbutton will also remove ground from the collector of Q1 in the call control unit. Current to the input of the proceed-to-dial circuit (base of Q1) is supplied from the spacing contact of the receiving polar relay. This is not shown in Figure 11. The proceed-to-dial circuit will not operate until this current is interrupted.

#### I. Proceed-to-Dial

3.75 The exchange will recognize the marking signal transmitted as a request to dial. When the exchange has selected the proper equipment, it will transmit a 0.025 second marking signal on the receiving leg. The receiving polar relay will respond to this signal by interrupting the current flow to the input of the proceed-to-dial circuit. This circuit will then turn on, and energize the (K1) relay and the proceed-to-dial lamp. The "a" contact will operate and shunt out the START pushbutton contact. The START pushbutton may now be released.

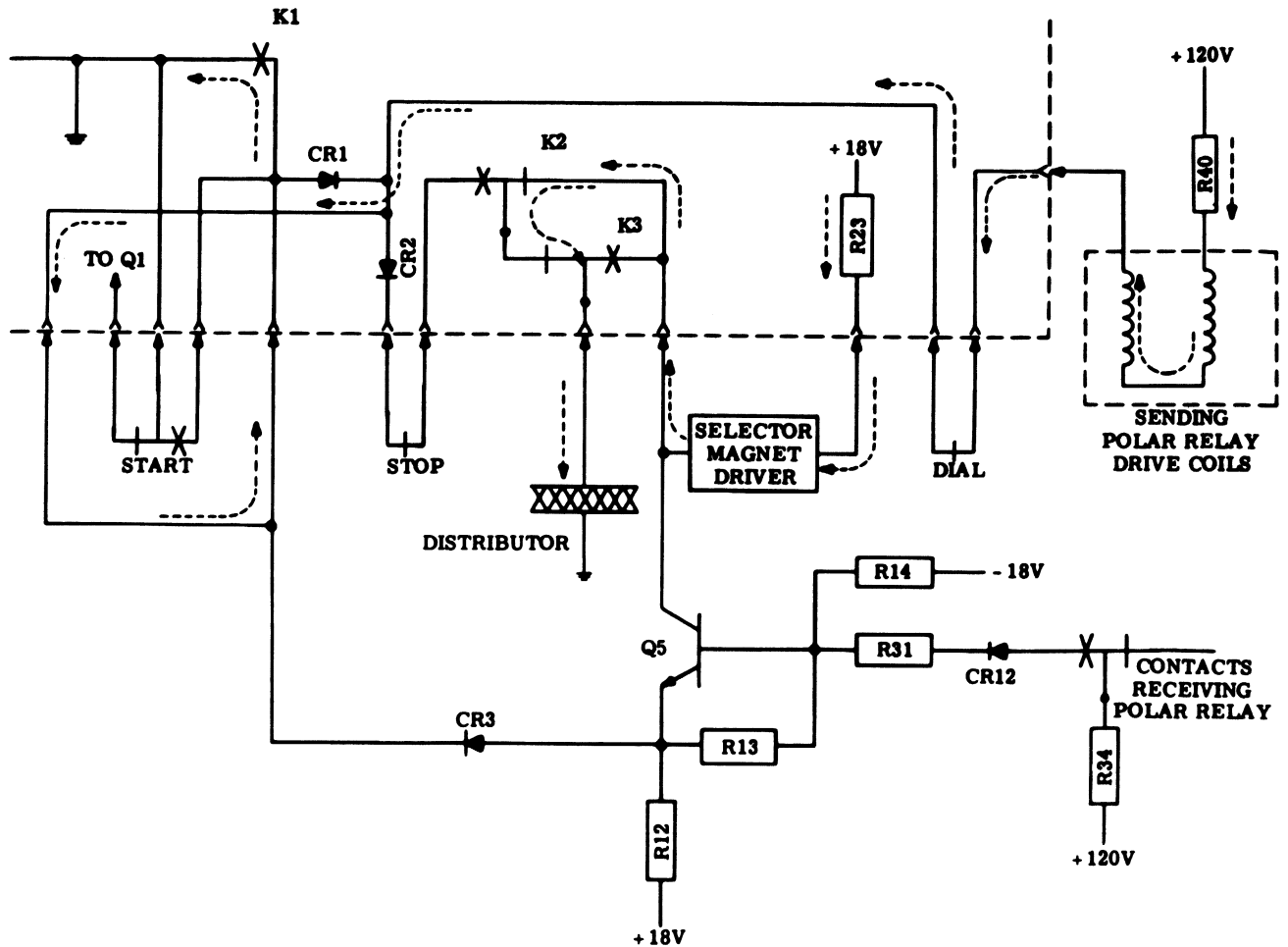

Figure 11 - Sending Loop Control Circuit With Sending Polar Relay

3.76 When the receiving polar relay responds to the 0.025 second pulse, C3 in the connect control timer will start to discharge. After 0.025 second the receiving leg returns to spacing and causes C3 to be recharged to -60 volts. In the 0.025 second interval, the voltage across C3 will not rise to -9.1 volts, and no strobe pulse will be passed by CR5. The connect control timer, therefore, will not respond to a proceed-to-dial pulse.

#### J. Dialing

3.77 The dial signaling contacts are in series with the drive coils of the sending polar relay as shown in Figure 11. The dial contacts will thus energize and de-energize this relay whenever current is flowing through them. The make-break signal generated by the dial contacts will be transmitted as mark-space signals by the sending polar relay. These mark-space signals are used by the exchange to make the necessary connection.

#### K. Call Connection

3.78 With the call control unit in the proceed-to-dial condition, the sending leg is marking, and the receiving leg is spacing. When dialing is completed, the exchange will switch the receiving leg to marking. This signal causes the tongue of the receiving polar relay to transfer and apply +120 volts to R28. CR8 will become reverse-biased, and C3 will begin to discharge toward ground. After 0.080 second, the voltage across C3 will be approximately -9.1 volts. The next strobe pulse to appear will pass through CR5 to the base of Q4. The output of the connect control timer will then become positive and cause the connect circuit to turn on. As described earlier, the proceed-to-dial circuit will turn off. As the connect circuit turns on, the (K2) relay will operate, the "hl" contacts will transfer, the CONN lamp will light, and the motor will turn on.

3.79 Current flow to the drive coils of the sending polar relay is now through R40, the drive coils, the dial contacts, CR2, the stop contacts, K1, K2, and the keyboard

contacts to ground as shown in Figure 12. Base current to Q5 is now supplied from the marking contact of the receiving polar relay through CR12 and R31. Input current to the selector magnet driver will flow from +18 volts through R23, the selector magnet driver, Q5, CR3, CR2, the stop contacts, K1, K2, and the distributor contacts to ground.

3.80 Both the current paths for the drive coils of the sending polar relay and the selector magnet driver are through the distributor contacts. If the distributor is operated, the signal will be transmitted on the sending leg and cause the selector magnet of the teletypewriter to operate. When information is received from the distant station, the receiving polar relay will operate and make or break base current to Q5. This will cause Q5 to make or break current flow to the selector magnet driver without affecting the sending circuit.

3.81 The longest possible normal spacing signal generated by the distant teletypewriter will be less than 1.3 seconds. This is the length of spacing signal required

to cause the connect control timer to disconnect. Therefore, under normal signaling, the connect control timer will not be affected by information signals.

L. Remote Connection

3.82 The call control unit may be connected remotely from either the idle line or local condition. An incoming call is indicated by the exchange by its transmission of a marking signal on the receiving leg. The connect control timer after 0.080 second, will turn on the connect circuit in the control unit. A current path to ground is set up through the drive coils of the sending polar relay. It will then transmit a marking signal on the sending leg to signify that the unit has connected. The remainder of the operations are the same as described in 3.78 through 3.81.

3.83 If the paper in the teletypewriter has become low and the low-paper contacts operate, the voltage across C3 will be held at -60 volts through R29. This will stop any connections from occurring. If the call control unit is

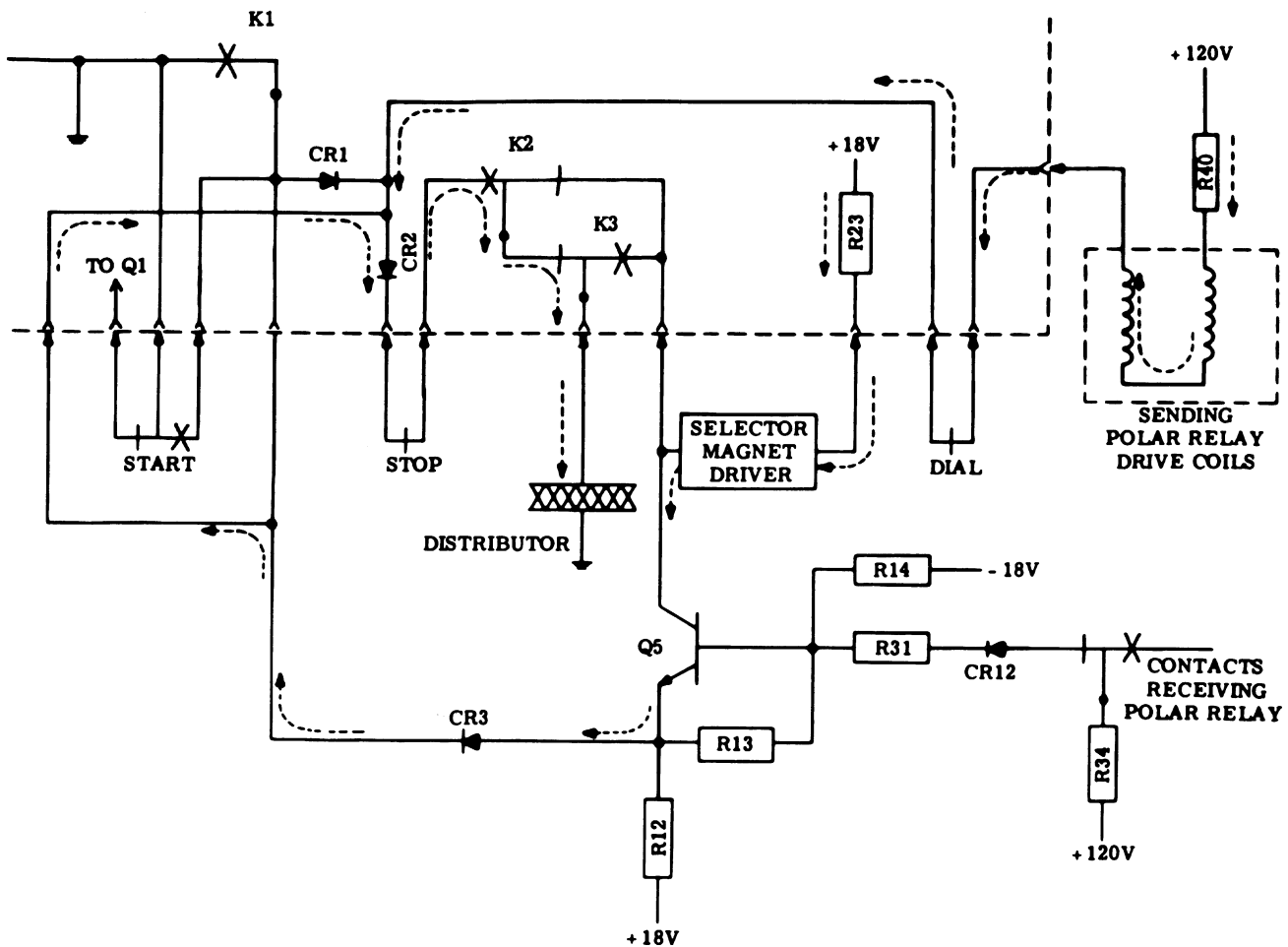

Figure 12 - Receiving Loop Control Circuit With Receiving Polar Relay

already in the connect condition, when the low-paper contacts close the call may be completed, but subsequent connections will be blocked.

3.84 If a call is originated locally with a low-paper condition, the normal sequence of events will occur until the connection is attempted. When the exchange does not receive a marking signal on the sending leg, it will turn the receiving leg to spacing (idle line condition).

**M. Call Disconnect**

3.85 If the STOP pushbutton is depressed while the teletypewriter is in the connect condition, the stop contacts in series with the drive coils of the sending polar relay will open. The relay output will then be spacing. The exchange will recognize this long spacing signal as a request to disconnect and will send a spacing signal on the receiving leg. The receiving polar relay contacts will transfer and allow C4 to discharge toward ground. After 1.3 seconds, the voltage across C4 will be -9.1 volts, and the next strobe pulse will pass through CR4 to the base of Q3. The output of the timer will become negative and turn off the connect circuit in the call control unit. Current to the drive coil of the sending polar relay will be held off so that the STOP pushbutton may be released. The K2 contacts will now also supply blinding current to the selector magnet driver. The control unit is now in the idle line condition.

**N. Remote Disconnect**

3.86 When the remote unit generates the spacing signal to disconnect, the receiving polar relay will allow C4 to discharge and after 1.3 seconds the timer will turn off the connect circuit. The K2 contacts will transfer, stopping current flow to the drive coils of the sending polar relay and blinding the selector magnet driver. The call control unit is now in the idle line condition.

**O. Local Off-Line Operation**

3.87 This operation is identical to that of the call control unit without polar adapter except for the current path to the selector magnet driver. This path is shown in Figure 11.

**4. PRIVATE WIRE SERVICE**

**INTRODUCTION**

4.01 Power for the motor, selector magnet driver, local power supply, and tape reader power pack, when provided, is supplied from fused 115-volt ac, 60 Hz power. Direct current of either 0.020 or 0.060 ampere is required for the signal line(s) and for operation in the local mode. Battery for the signal line(s) is supplied by the customer's facilities, while local battery for operation in the local mode is

furnished through the operation of the local power supply circuit in the call control unit. At the rear of the call control unit is a terminal strip which provides the point of entry for the ac power and the signal line(s) into the teletypewriter.

4.02 The purpose of the selector magnet driver is to amplify received dc marking and spacing intelligence pulses. Received dc intelligence pulses are directed to the input of the selector magnet driver circuit in the call control unit where they are amplified and returned as 0.500 ampere dc intelligence pulses to operate the typing unit selector. A detailed description of the operation of a selector magnet driver is given in 2.92 through 2.102. The selector magnet driver described there is similar to the ones used in private wire service.

**A. Power Switch and Local Power Supply Circuits**

4.03 The 3-position rotary switch (electronically shown in Figure 13) is the only manual control on the call control unit. Through its operation the teletypewriter can be (1) placed in the external signal line loop for communication with other teletypewriters, (2) removed from the external signal line loop for local operation, or (3) placed in the off condition.

**B. Mode Chart**

4.04 The following chart indicates the condition of the rotary power switch contacts – either open or closed – when the control knob is turned to one of its positions:

KNOB POSITION	LINE SEGMENT		CONTACTS CONDITION
	FROM	TO	
LINE	L1	2	Closed
	L1	1	Closed
	L2	2	Open
LOCAL	L1	2	Closed
	L1	1	Open
	L2	2	Closed
OFF			All Open

**OFF MODE**

**A. Power Circuit**

4.05 All power in the call control unit, except that applied to the selector magnet driver is off.

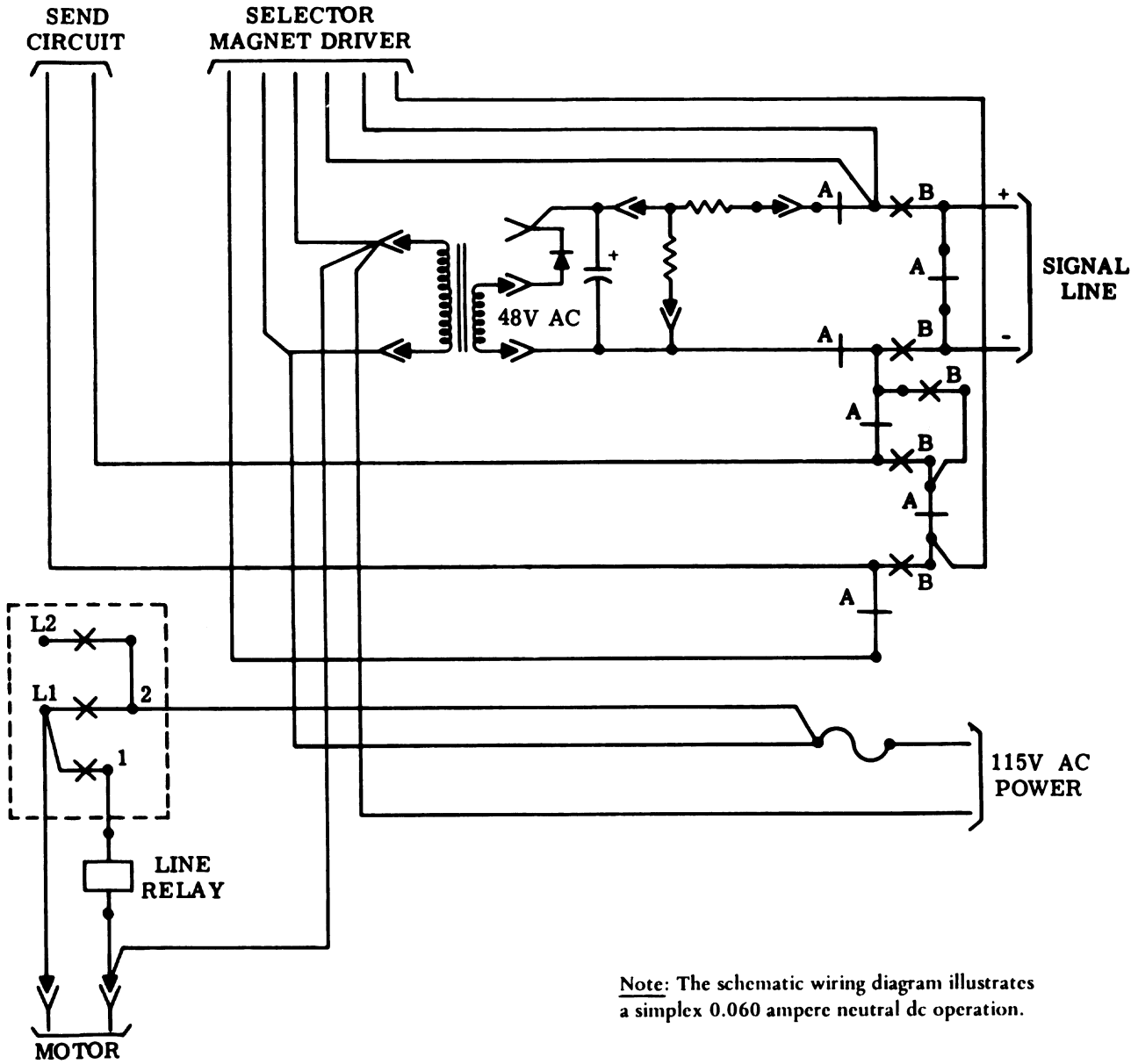

Note: The schematic wiring diagram illustrates a simplex 0.060 ampere neutral dc operation.

Figure 13 - Rotary Power Switch and Local Power Supply Circuit



**B. Signal Circuit**

**4.06** The signal line is diverted around the local teletypewriter so other teletypewriters in the external signal line loop can communicate without interference.

**LOCAL MODE**

**A. Power Circuit**

**4.07** The line relay is not energized and the local battery is supplied to the selector magnet driver and the send circuit.

**B. Signal Circuit**

**4.08** The normally closed contacts A remain closed, and the normally open contacts B remain open. The external signal line loop is divorced from the selector magnet driver, and shunted so that other teletypewriters in that loop can communicate without being affected by the operation of the local teletypewriter.

**LINE MODE**

**A. Power Circuit**

**4.09** The line relay is energized and the battery is on the signal line.

**B. Signal Circuit**

**4.10** The normally closed contacts A will open and the normally open contacts B will close. The external signal line loop is united with the selector magnet driver and the local teletypewriter can now communicate any other teletypewriters in that loop.

**4.11** Any transmission from the keyboard or tape reader, if provided, will cause the typing unit distributor to send start-stop signals to other teletypewriters in the external signal line loop. Also, the local teletypewriter is able to receive the start-stop signals transmitted from other teletypewriters in the same external line loop.



33 TELETYPEWRITER SET  
 INSTALLATION

CONTENTS	PAGE	
1. GENERAL . . . . .	1	1. GENERAL
UNPACKING . . . . .	1	1.01 This section provides instructions for unpacking, installing, connecting, and preparing the 33 Teletypewriter Set for use. It is reissued to provide exclusive coverage of the 33 Teletypewriter Set and to update the section. Since this is a general revision, marginal arrows used to indicate changes and additions are omitted.
PREPARATION FOR INSTALLATION . . . . .	2	1.02 References to left, right, front, or rear, etc, consider the teletypewriter set to be viewed from a position where the typing unit carriage faces up and the typing unit selector mechanism is located to the viewer's left.
2. INSTALLATION . . . . .	3	1.03 Tools and materials used for teletypewriter set installation are shown in Section 570-005-800TC.
MOUNTING TYPING UNIT ON STAND . . . . .	3	
CODING ANSWER-BACK DRUM . . . . .	3	
ELECTRICAL CONNECTION . . . . .	7	
ADJUSTMENTS . . . . .	8	
PLACEMENT . . . . .	8	
A. Without Stand . . . . .	8	
B. With Stand . . . . .	8	
3. FINAL ASSEMBLY . . . . .	8	<u>Note:</u> To avoid injury, take special care when working with a teletypewriter set connected to its power supply.
GENERAL . . . . .	8	
RIBBON INSTALLATION . . . . .	8	
PAPER OR FORM INSTALLATION . . . . .	9	1.04 Leads for the signal line must be furnished by the customer.
A. Friction Feed . . . . .	9	
B. Sprocket Feed . . . . .	10	UNPACKING
4. OPTIONAL FEATURES . . . . .	12	1.05 The teletypewriter set is packed in one carton. Observe all caution and instruction labels on the carton before breaking the seals.
A. Copyholder . . . . .	12	
B. Busy Circuit . . . . .	12	
C. Hand Receiver . . . . .	13	
5. TAPE READER . . . . .	13	
6. POWER PACK ASSEMBLY . . . . .	13	1.06 Cut tape at center and end seams. Open carton and remove the upper filler pads. Remove typing unit carefully to avoid damaging the plastic cover. Take out the remaining carton fillers and the stand (if used).
7. TAPE PUNCH . . . . .	13	
8. RESHIPMENT . . . . .	15	

1.07 The typing unit and subbase are mounted on a shipping pallet by seven screws. Four of the screws are TP181237 self-tapping screws that secure the subbase to the pallet. The remaining three are standard machine screws that pass through aluminum bushings into tapped holes in the typing unit's base casting.

1.08 Tilt the shipping pallet and remove the screw from the countersunk hole; loosen remaining six screws. Return pallet to its upright position. Slide pallet slightly beyond the edge of the bench; remove the six loosened screws.

Note: Retain the forward mounting screw and associated flat washer. This screw is used to secure the typing unit when shipped to another location without its cover fastened in place. The screw and washer may be stored in the TP181104 cable clip (included in bag of hardware with pedestal mounted units) to be mounted on the typing unit frame between the two dashpot mounting screws (Figure 1).

Remove typing unit from the shipping pallet.

**CAUTION: DO NOT TILT THE TYPING UNIT AFTER IT HAS BEEN REMOVED FROM THE PALLET. THE TYPING UNIT FLOATS ON RUBBER ISOLATORS AND MAY PULL LOOSE IF IT IS TILTED.**

## PREPARATION FOR INSTALLATION

1.09 Remove the tape from across the top of the cover and take out the cables, platen knob, and paper spindle from the paper recess. Unwrap the parts.

1.10 Remove the call control bezel, if used, after removing its two mounting screws. Remove volume control knob or power switch rotary knob, if used, by pulling knob forward. Detach the nameplate (Figure 2) by pulling it down and out. Remove the four front and three rear cover mounting screws.

Note: On Automatic Send-Receive (ASR) Sets, remove the screw from the left rear corner of the tape reader cover.

Gently lift the cover from the subbase.

1.11 Remove the twist tie holding the carriage to the left side frame and the tissue paper retaining the spacing pawls.

Note: If the teletypewriter is an ASR Set with early design tape reader, remove the retaining clip from the tape reader upstop screw (Figure 11).

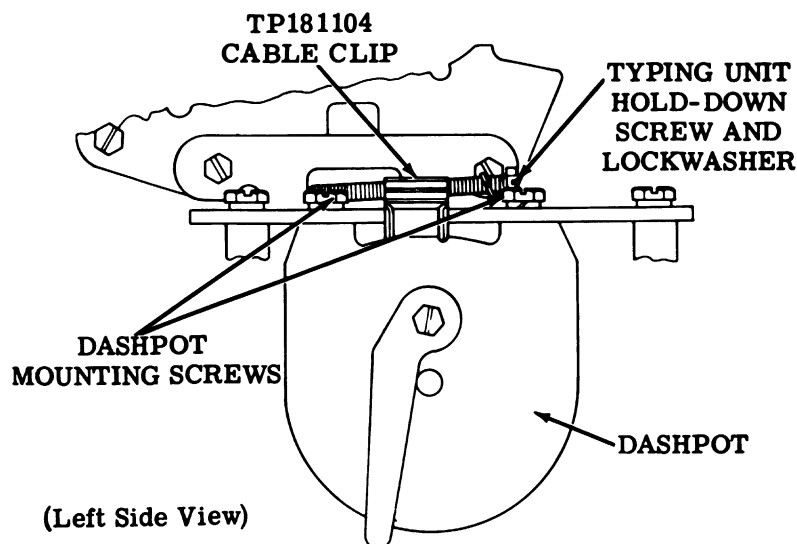

Figure 1 - Typing Unit Hold-Down Screw Storage

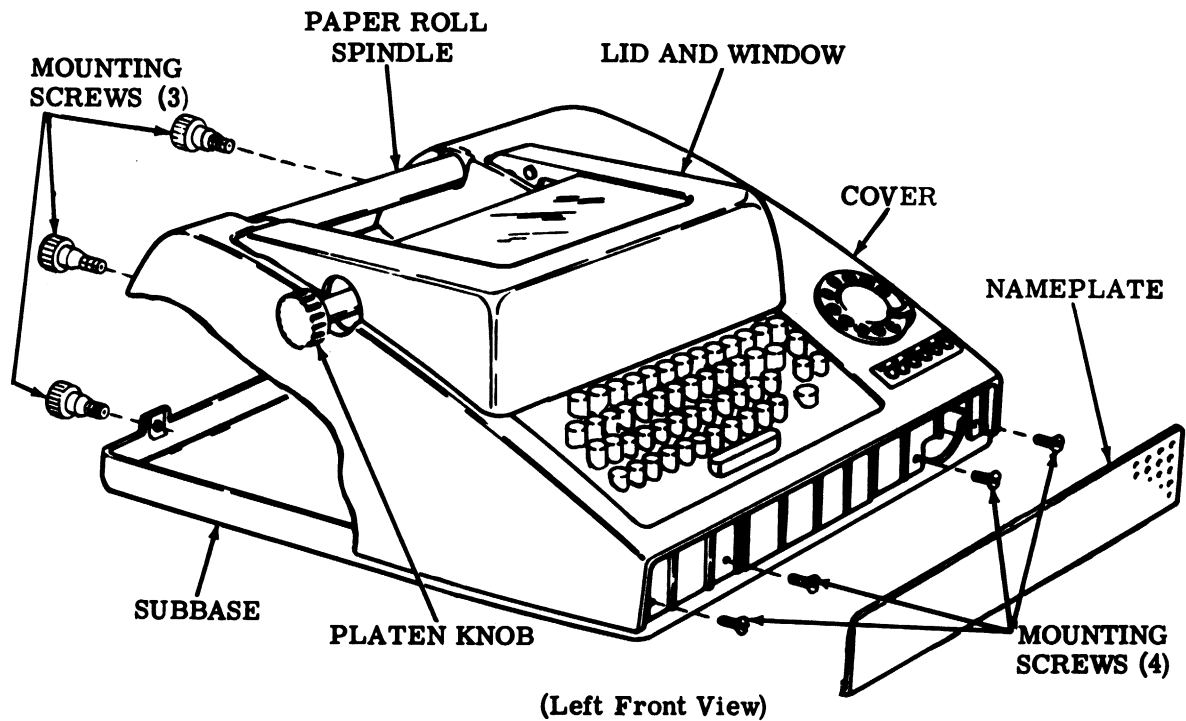

Figure 2 - Cover Mounting

1.12 If a stand is used, remove its two rear panel mounting screws and take panel off. Remove the copyholder, if used, from inside the stand. Remove the bag tied to the stand and place its hardware contents on the bench.

1.13 Use the supplied screws to fasten the data set, if used, to the relay rack.

1.14 The teletypewriter set should be thoroughly lubricated before placing it into service and relubricated after a short period of service. Thereafter, maintain the regular lubrication intervals as required in the appropriate lubrication sections.

## 2. INSTALLATION

### MOUNTING TYPING UNIT ON STAND

2.01 If the teletypewriter set is to be bolted to the floor, remove the front screw in each leg of the stand (Figure 3).

2.02 Install the plug button, included in the bag of hardware, in the forward hole in the bottom of the subbase.

2.03 Place the subbase and typing unit on top of the stand so that its back edge and sides line up with the back edge and sides of the stand.

**CAUTION: PROVIDE SUPPORT FOR THE SUBBASE UNTIL THE TWO REAR MOUNTING SCREWS ARE TIGHTENED.**

Mount subbase to the stand using four TP181237 screws and four TP125928 flat washers in the hardware bag (Figure 3); when supplied, use 10-32 hex head screws with flat washers and lockwashers in the two front tapped subbase bosses. Tighten the mounting screws.

### CODING THE ANSWER-BACK DRUM

2.04 To remove answer-back drum for coding, press back and down on the tab portion of the TP180854 brace until it becomes detented in its open position. Lift feed pawl slightly (do not overextend its spring) and remove drum.

2.05 Code the answer-back drum in a counter-clockwise direction (Figures 4 and 5), starting with row no. 1.

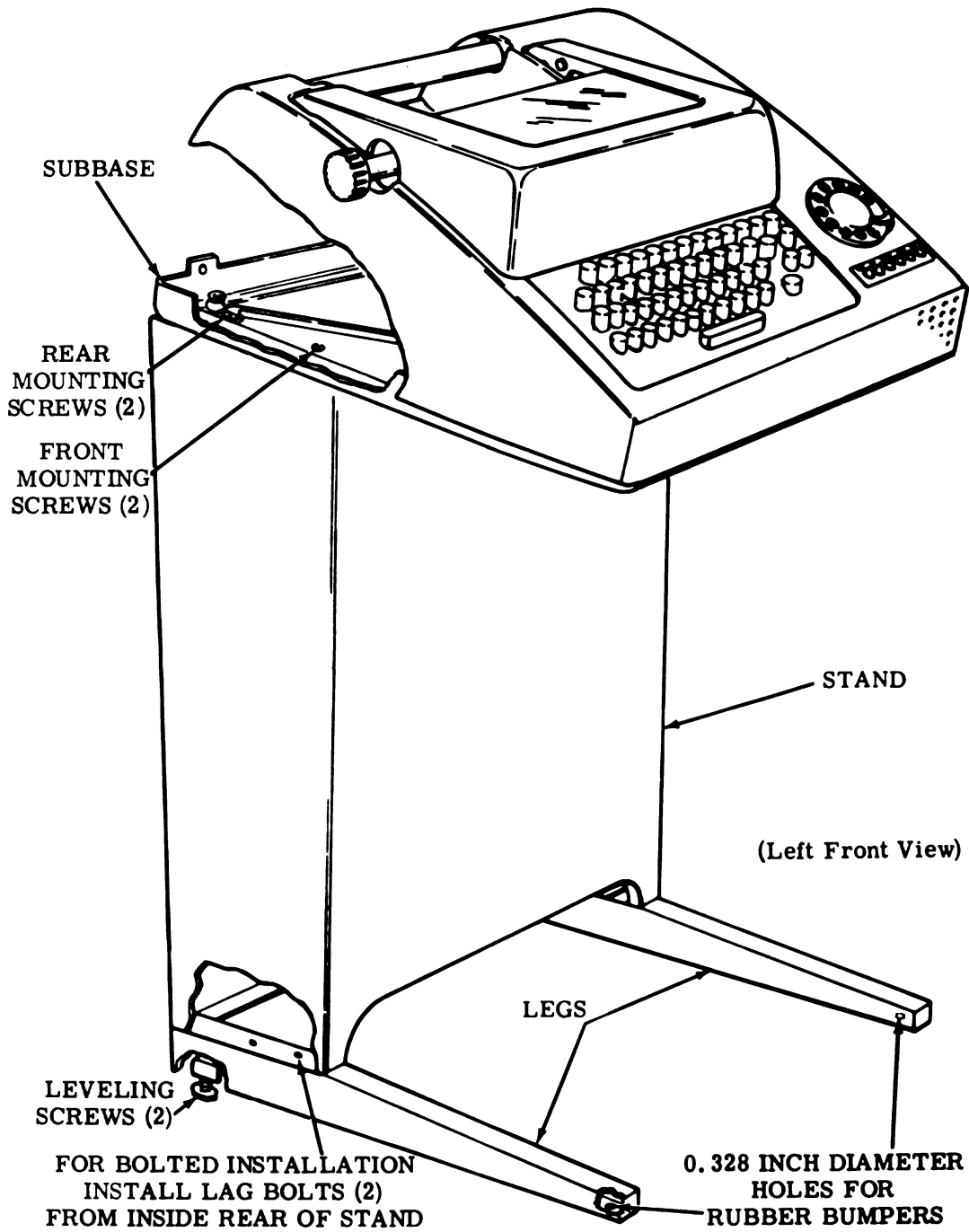

Figure 3 - Stand Leveling and Anchoring and Assembly of Subbase with Typing Unit to Stand

Note: The ST row is the first row sensed at the beginning of an answer-back cycle. It is coded at the factory for character suppression and must not be recoded.

2.06 A particular character is coded by either retaining or removing tines within a row, as illustrated in Figure 4. A tine may be removed by either of the two following methods:

(a) Method 1: Place the end of a screwdriver blade at the base of a tine in the row previously coded. Press the side of the blade against the top of the unwanted tine until the tine breaks off. Figure 4 illustrates this method — pressure applied to base of

row no. 18 and against top of adjacent tine being removed from row no. 19.

(b) Method 2: Place the unwanted tine in the slot of a TP161686 tine tool, or grasp the tine firmly with long-nose pliers. With the tool or pliers held stationary, rotate the answer-back drum back and forth until the unwanted tine breaks off near its base. Do not damage adjacent tines.

Note: If a coding error is made, or for some other reason it is necessary to suppress (erase) characters from the answer-back drum, remove the character suppression tine from the row(s) affected.

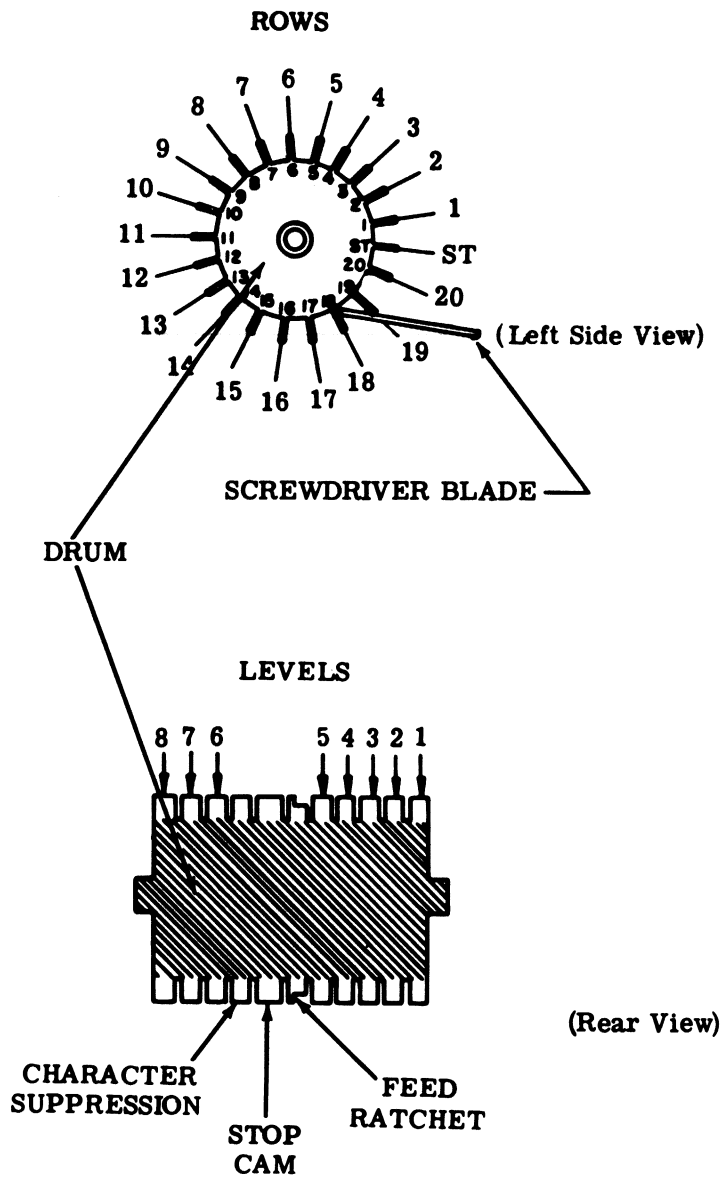

Figure 4 - Answer-Back Drum

CODE LEVELS										ASCII CODE			CODE LEVELS										ASCII CODE				
8	7	6			5	4	3	2	1	1967 Edition	1965 Edition	1963 Edition	8	7	6			5	4	3	2	1	1967 Edition	1965 Edition	1963 Edition		
										NUL	NULL											2					
										SOH	SOM												3				
										STX	EOA												4				
										ETX	EOM													5			
										EOT														6			
										ENQ	WRU													7			
										ACK	RU													8			
										BEL	BELL													9			
										BS	FE <sub>0</sub>												:				
										HT	HT/SK												;				
										LF													<				
										VT	VTAB												=				
										FF													>				
										CR													?				
										SO													@	\	@		
										SI													A				
										DLE	DC <sub>0</sub>												B				
										DC1														C			
										DC2														D			
										DC3														E			
										DC4	DC4 (STOP)													F			
										NAK	ERR													G			
										SYN	SYNC													H			
										ETB	LEM													I			
										CAN	S <sub>0</sub>													J			
										EM	S <sub>1</sub>													K			
										SUB	SS	S <sub>2</sub>												L			
										ESC	S <sub>3</sub>													M			
										FS	S <sub>4</sub>													N			
										GS	S <sub>5</sub>													O			
										RS	S <sub>6</sub>													P			
										US	S <sub>7</sub>													Q			
										SP	b													R			
																								S			
																								T			
										#														U			
										\$														V			
										%														W			
										&														X			
										'														Y			
										(														Z			
										)														c			
										*														\	~	\	
										+														^			
										-														~			
										.														~			
										/														~			
										0														~			
																								DEL			

1 CYCLE OPER. ROW 6																																
1 CYCLE OPER. ROW ST																																
2 CYCLE OPER. ROWS 6 & 17																																
2 CYCLE OPER. ROWS ST & 11																																
3 CYCLE OPER. ROWS 6,13,20																																
3 CYCLE OPER. ROWS ST, 7,14																																

CHARACTER SUPPRESSION ———

STOP CAM ———

FEED RATCHET ———

■ LEAVE TINE

□ REMOVE TINE

Note 1: Blank space indicates no change from latest edition.

Note 2: Codes shown are for even parity operation --- for nonparity, remove eighth level tine.

Figure 5 - Answer-Back Drum Coding



2.07 The length of an answer-back sequence can be varied either by removing the stop cam tine(s) and/or the character suppression tine(s).

(a) For short sequences, code the drum for either 2- or 3-cycle operation by removing the appropriate tine(s) as indicated in Figure 5.

(b) Removal of the character suppression tine from any row prevents transmission from the answer-back mechanism. To shorten the answer-back sequence, remove the suppression tine from any unused row(s) after the end of a message.

Note: Do not remove the character suppression tine from the last row of each segment of the answer-back drum — row no. 20 for answer-back drums coded for 1-cycle operation — on sets used in systems where a response to each answer-back activation signal must be obtained. The last row can be coded with any other character that is compatible with the particular system.

2.08 The number of rows available for message coding is shown below for 1-, 2-, or 3-cycle operation.

CYCLE OPERATION	TOTAL ROWS	AVAILABLE ROWS
1	21	20
2	10 (11)*	9 (10)*
3	7	6

\*Alternately one, then the other.

2.09 The number of rows available for actual station identification is less than shown above, because each coded message should begin and end with CARRIAGE RETURN and LINE FEED (this may be altered in specific applications). This assures that the transmitted message will appear at the beginning of a line of the receiving teletypewriter set and eliminates overprinting.

2.10 In switched network service, the station identification for 1-cycle operation may not exceed 14 characters, including spaces. The answer-back drum should be coded as follows.

ABBREVIATION                      KEY TO ABBREVIATION

ACK	Acknowledge
CR	Carriage Return
LF	Line Feed
RO	Rub Out
SP	Space
SUP	Character Suppression

(a) Example 1:

SUP CR LF RO  
 TELETYPE SP NILES CR LF ACK  
 Company                      City

Station Identification  
 (Maximum-14 characters)

Note: In this system, the ACK character code combination must be the final significant character code combination in the coded answer-back message.

(b) Example 2:

SUP CR LF RO  
 ERIE SP BOST CR LF ACK SUP  
    SUP SUP SUP SUP  
 Company                      City

Station Identification  
 (Less than maximum number of characters)

Note: If the station identification is less than the maximum of 14 characters in length, then the remaining rows on the answer-back drum must be coded with the character suppression code according to Example 2 above.

2.11 To replace the answer-back drum, place the TP180854 brace in its detented open position, and lift feed pawl (do not overextend its spring). Replace drum with its shaft firmly seated in the contact block slots. Release feed pawl and TP180854 brace. Rotate answer-back drum to assure proper seating of its associated parts. Check that the contact wires are located in their proper slots.

**ELECTRICAL CONNECTION**

**CAUTION: MAKE SURE POWER CORD IS NOT CONNECTED.**

2.12 Refer to the appropriate wiring diagrams packed with teletypewriter set or to the appropriate wiring diagrams if available.

## SECTION 574-100-201TC

2.13 Connect the signal line leads (supplied by customer) to the terminals on the terminal board at the rear of the call control unit as indicated in the wiring diagram.

2.14 Connect power cord to an ac source, 115-volt 60 hertz.

### ADJUSTMENTS

2.15 Check DASHPOT ORIFICE (Spacing Area) adjustment, since altitude may have some affect on dashpot operation. See the appropriate typing unit section for adjusting procedure.

2.16 Sets equipped with an answer-back mechanism must be tested for proper response to a predetermined call character such as WRU. The following procedure is recommended for performing this test.

(a) Use a predetermined call character such as WRU, to call in the newly installed set.

(b) The set should establish the connection and automatically transmit the answer-back message.

Note: Set will not respond if the suppression tine has been removed from the last row. See 2.07 (b).

(c) If proper response is not obtained, check and correct the answer-back area adjustments (Section 574-122-700TC), beginning with those of the following list.

DRUM POSITION

TRIP LEVER CLEARANCE

FEED PAWL POSITION

FEED LEVER POSITION

"HERE-IS" BELLCRANK POSITIONING

TRIP BAIL POSITIONING

CHARACTER SUPPRESSION CONTACT

WIRE GAP

### PLACEMENT

#### A. Without Stand

2.17 If a stand is not included, place the teletypewriter set on the surface where it is to be used.

#### B. With Stand

2.18 Figure 3 illustrates the facilities for leveling and anchoring the stand.

2.19 Place the partially assembled set where it is to be used. If the set rocks to one side or another, tip it slightly and reposition the leveling screws.

Note: Reaction to the carriage returning to its left position may cause early design teletypewriter sets to move across the floor toward the left. To correct this, either add weight to the stand, arrange to have it bolted to the floor, or drill one 0.328 inch diameter hole into each leg and install TP182285 rubber bumper in each leg.

2.20 If the teletypewriter set is to be bolted to the floor, place stand at the desired location and drive lag bolts into the floor through the front holes in the legs.

2.21 Place the relay rack inside the stand.

### 3. FINAL ASSEMBLY

#### GENERAL

3.01 Replace the back panel onto the stand, if used, using the removed screws.

Note: Before replacing an ASR cover, remove the retaining clip (early design units only) from the tape reader upstop screw (Figure 11).

3.02 Replace the cover over the typing unit and onto the subbase (Figure 2). Take care that all seams are tight and that keyboard push-buttons, dial, etc, are properly aligned. Insert and tighten the cover mounting screws removed during PREPARATION FOR INSTALLATION.

Note: On an ASR Set, insert and tighten screw at left rear corner of tape reader cover.

3.03 Replace the nameplate making sure that the formed lip fits around the bottom of the flange on the cover, that the top edge is behind the small lip on the cover, and that the bottom of the nameplate rests on top of the two small projections on the subbase.

3.04 Replace the volume control knob or the power switch rotary knob, if either is used, by positioning and pushing it rearward.

3.05 Position the bezel, if used, on the cover over the call control unit. Insert and tighten its two mounting screws.

3.06 On friction feed typing units, align the platen knob with the flat on the left side of the platen. Push knob in place. On sprocket feed typing units, install platen knob on left side of platen. Fully seat knob to the right and secure it with the screw provided.

#### RIBBON INSTALLATION

3.07 Figure 6 illustrates ribbon threading.

3.08 Raise the cover lid. Pull both spools off the friction spindles.

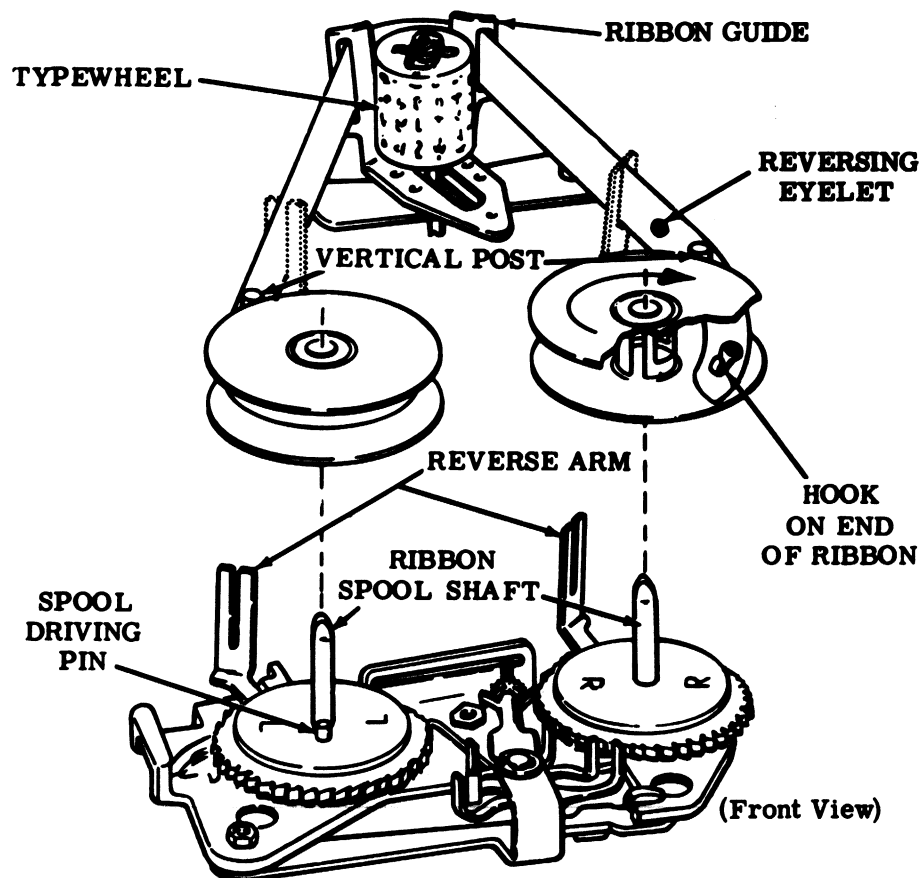

Figure 6 - Ribbon Threading

**3.09** Engage the hook at the end of the ribbon in the hub of the empty spool; if there is no hook, pierce the end of the ribbon over the point of the arrow in the hub of the empty spool. Wind a few turns of ribbon onto the empty spool in the direction indicated by the arrow, and make sure that the reversing eyelet has been wound upon the spool.

**3.10** Place the spools on the shafts in such a manner that the ribbon feeds to the rear from the right side of the right spool and from the left side of the left spool. Turn each spool slightly until the spool driving pin engages the hole in the spool. Guide the ribbon around the right vertical post and through the slot in the reverse arm. Place the ribbon in the ribbon guide behind the typewheel. Guide the ribbon through the left side of the reverse arm and around the vertical post. Rotate the spool to take up any slack.

## PAPER OR FORM INSTALLATION

### A. Friction Feed

**3.11** A frictionfeed teletypewriter set accommodates a standard roll of paper 8-1/2 inches wide and 5 inches in diameter. Figure 7 illustrates paper threading for a friction feed typing unit.

**3.12** Insert the paper roll spindle into the roll of paper so that an equal length of spindle is exposed at either end of the roll. Place roll into the cover recess with the ends of the spindle resting in the slots so that the paper will unroll from the bottom.

**3.13** Raise the cover lid. Release pressure roller tension by moving the pressure lever forward. Prepare a smooth leading edge

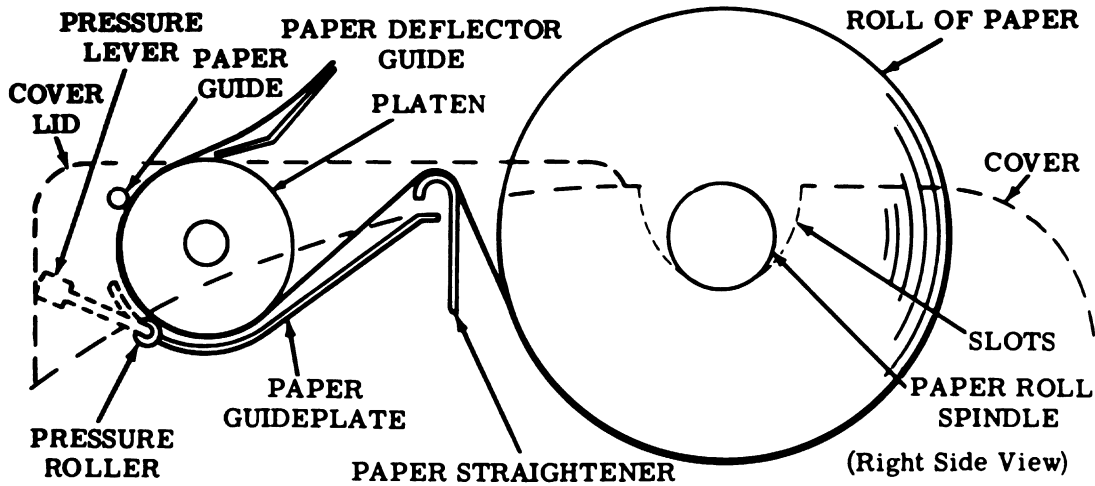

Figure 7 - Paper Threading — Friction Feed

of paper. Pass paper over paper straightener, under platen, and under paper guide. Straighten paper and reapply the pressure roller tension. Close the cover lid.

**Note:** When typing units are stored or out of service for an extended period of time, release the pressure roller tension.

#### B. Sprocket Feed

**3.14** A sprocket feed teletypewriter set accommodates forms 8-1/2 inches wide and of various lengths. The forms are normally passed to the typing unit from a conveniently located supply at the rear of the set.

**3.15** Place the paper roll spindle into the paper recess of the cover so that it rests in the slots provided.

**3.16** Figure 8 illustrates form threading for a sprocket feed typing unit.

**3.17** **Form Threading:** Raise the cover lid. Pass the leading edge of the first form under the paper roll spindle. Thread the form under the low-paper and paper-out arms, if used, and between the platen and paper guideplate. Guide the form squarely into the platen and rotate the platen until the form is advanced by the sprocket pins. Lift up the wire guide and continue to rotate the platen until the form is under

the wire guide and positioned for the first typing line. Lower wire guide and cover lid. After the first form is fed out, lift the form over the paper roll spindle to separate the incoming forms from the outgoing forms.

**3.18** Figure 9 illustrates the zeroizing position of the platen drive mechanism for one cam lobe operation. For platen drive mechanisms using more than one cam lobe, see the **CAM ZERO POSITION (Platen Drive Area, Sprocket Feed Mechanism)** adjustment in the appropriate typing unit adjustment section.

**3.19** **Zeroized Position:** Position a form at its first printing line in the typing unit. Depress the zeroizing button and rotate the pulley until the index plate is lined up with the pointer. Release the zeroizing button.

**Note 1:** To initiate the action to feed out a form, depress the CTRL and FORM keytops. The form-out mechanism will not respond to successive commands to feed out a form. At the end of a form feed-out, advance the form at least one line before issuing a second form-out command.

**Note 2:** The typing unit, in an ASR Set, operates one cycle behind the tape reader. Thus, a nonprint fill in code selection is required immediately after each form-out selection for proper set operation.

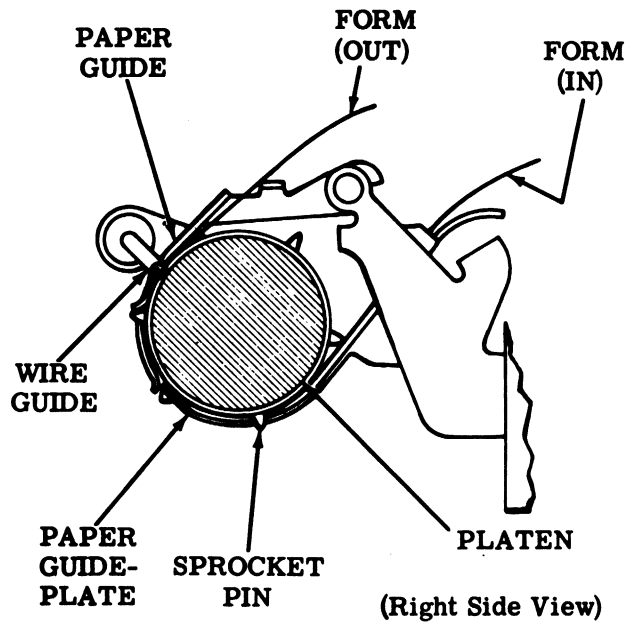

Figure 8 - Form Threading — Sprocket Feed

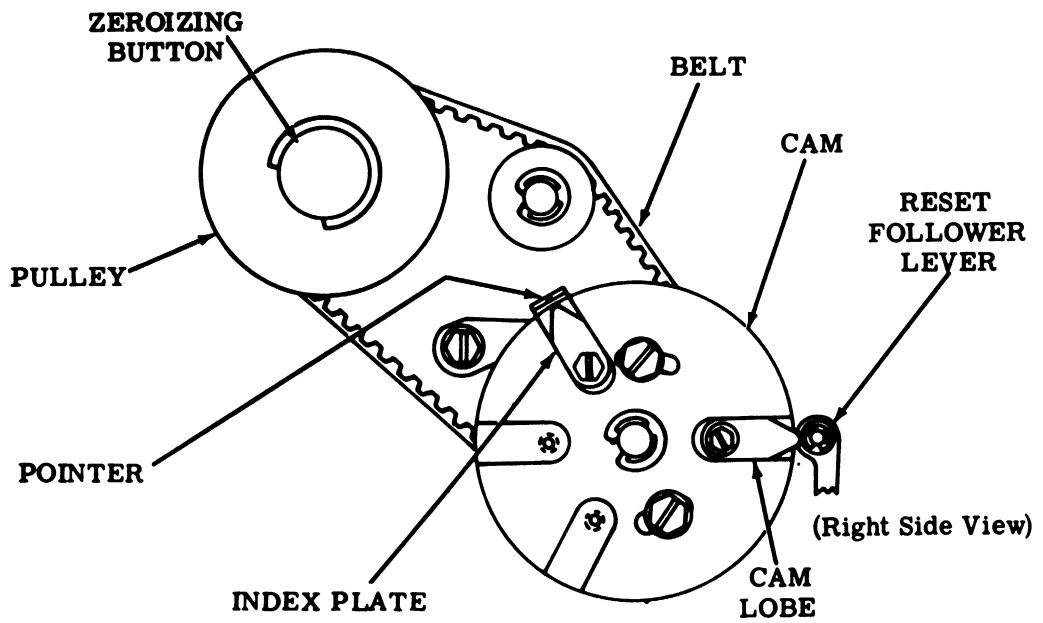

Figure 9 - Zeroizing Position of Platen Drive Mechanism — One Cam Lobe Operation

#### 4. OPTIONAL FEATURES

##### A. Copyholder

4.01 With the line guide facing forward (Figure 10), insert the rear mounting tabs in the lower mounting slots. Pivot the copyholder to align the front mounting tabs above their mounting slots. Push copyholder downward until the tabs are fully seated.

##### B. Busy Circuit

4.02 The teletypewriter set is normally wired in a "don't answer" mode of operation for low-paper alarms and out-of-service. In this mode, the set will not answer an incoming call. To wire the teletypewriter set to indicate "busy" instead of not answering, move the black-slate wire from terminal no. 2 to terminal no. 4 on the ringer terminal strip.

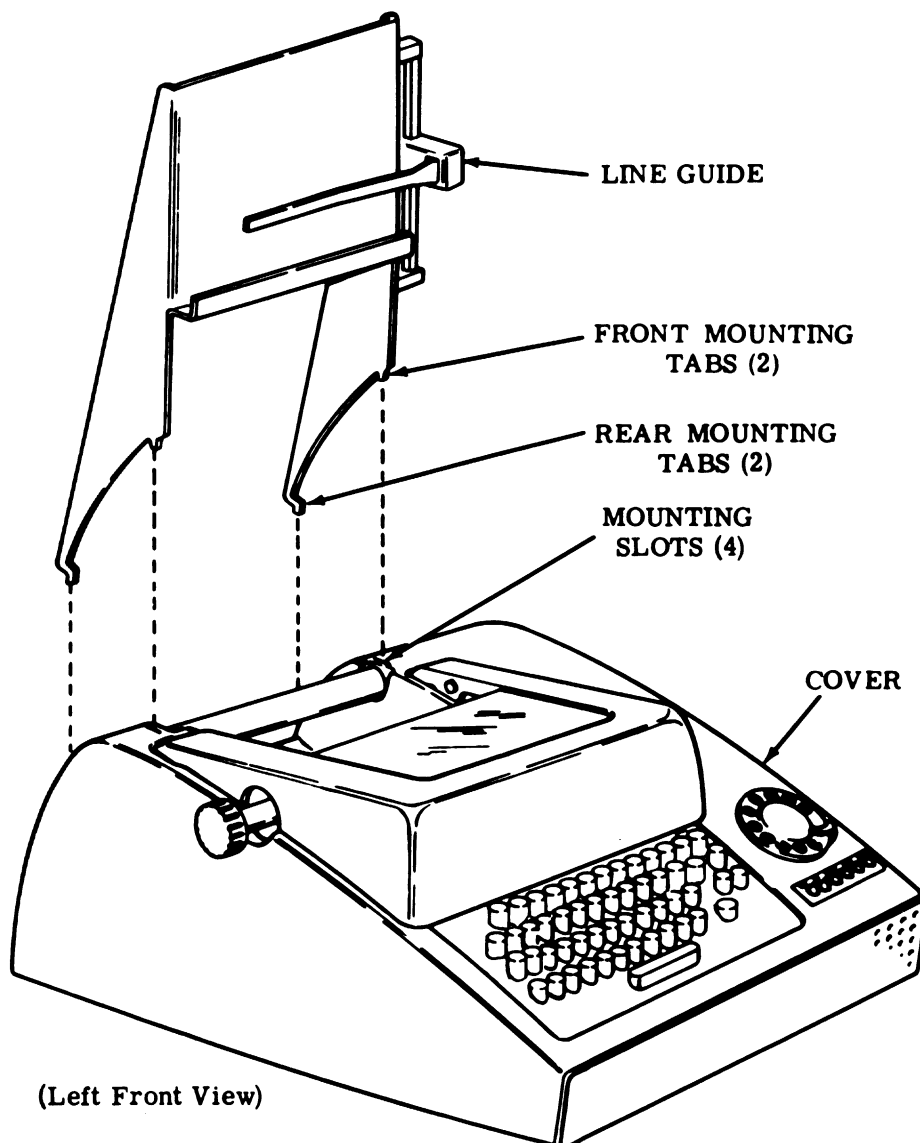

Figure 10 - Copyholder

### C. Hand Receiver

4.03 To install the hand receiver, connect the two white wires to terminals no. 5 and 6 on the 9-point terminal board.

### 5. TAPE READER

5.01 A retaining ring or clip (Figure 11) is assembled (on early design units) to the upstop screw to prevent the sensing pins from being dislodged during shipment. This retaining clip must be removed before placing the tape reader in operation.

5.02 When inserting tape into the tape reader prior to operation, allow enough slack in the tape between the tape punch and the reader so that the reader lid can be easily closed.

**CAUTION: THE TAPE READER OPERATES UNDER HIGH VOLTAGE. PRECAUTIONARY MEASURES SHOULD BE TAKEN WHENEVER POWER TO THE TAPE READER IS TURNED ON. HIGH VOLTAGE FROM THE POWER PACK WILL CONTINUE UNTIL APPROXIMATELY 10 SECONDS AFTER THE TAPE READER HAS BEEN DISCONNECTED.**

5.03 Do not place the control lever beyond the STOP position while the tape reader is operating under power. The reader must come to a complete stop before placing the control lever in the FREE position.

### 6. POWER PACK ASSEMBLY

6.01 Clip the power pack to the front panel inside the stand (Figure 12). Position the power pack approximately 1/2 inch from the right panel.

6.02 The auxiliary ASR power supply is mounted in the enclosure of the stand. It is used in the off-line mode to provide 115 volts on the tape reader, answer-back, and distributor contacts when a tape reader is used. When the tape reader is not used, a plug with a jumper wire is inserted in position R2 at the rear of the call control unit.

### 7. TAPE PUNCH

7.01 The tape punch, drive link mechanism, baseplate, and plastic cover are assembled at the factory.

7.02 Figure 13 illustrates the proper installation of a tape spool in a tape roll.

- (a) For 2-inch inside diameter tape rolls, use the tube-type spool.
- (b) For 1-inch inside diameter tape rolls, use the 2-piece spool.
- (c) Place the tape and spool into the tape punch cover so that the leading edge of the tape is at the top of the roll.

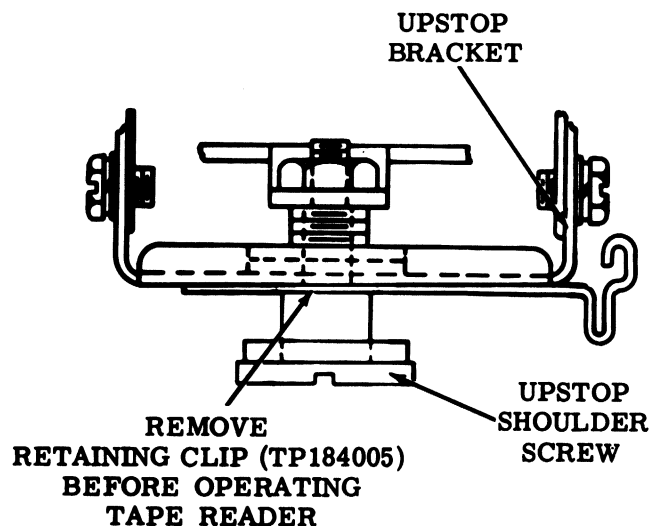

Figure 11 - Tape Reader Upstop Bracket Retaining Clip

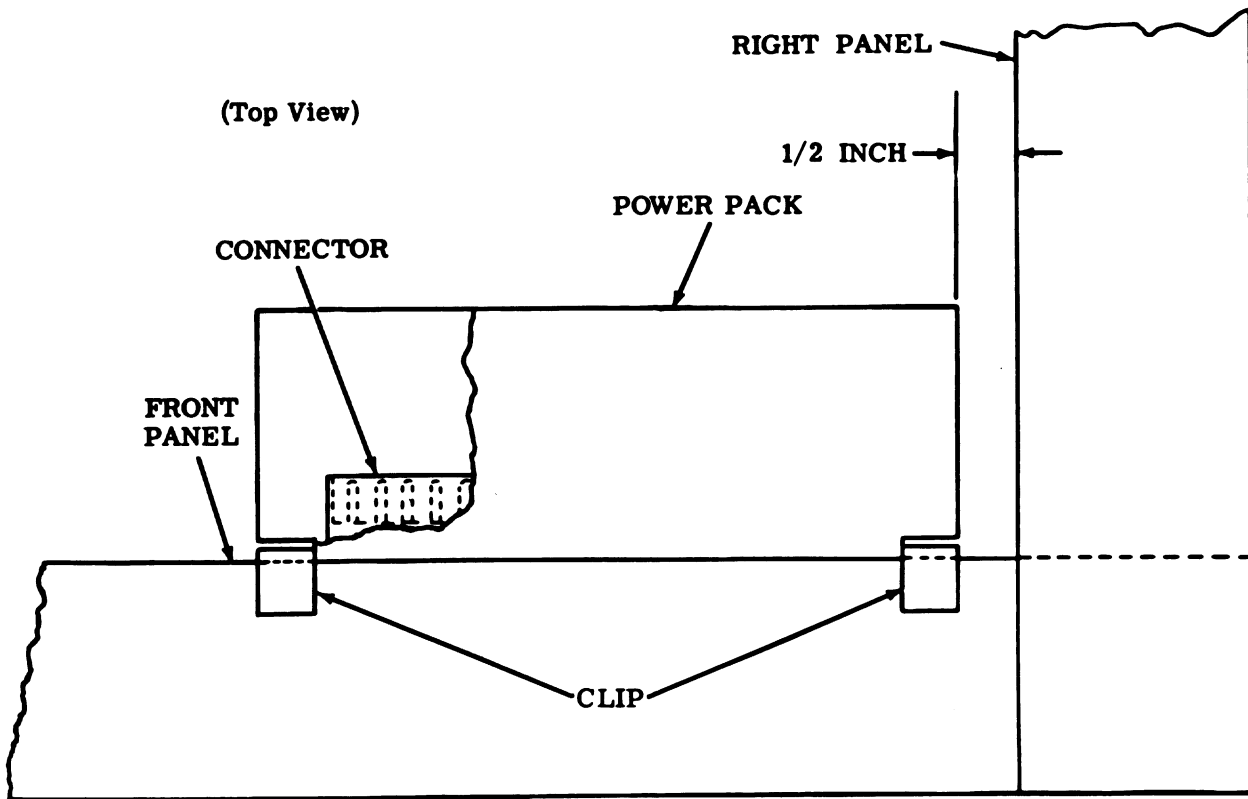

Figure 12 - Power Pack Assembly

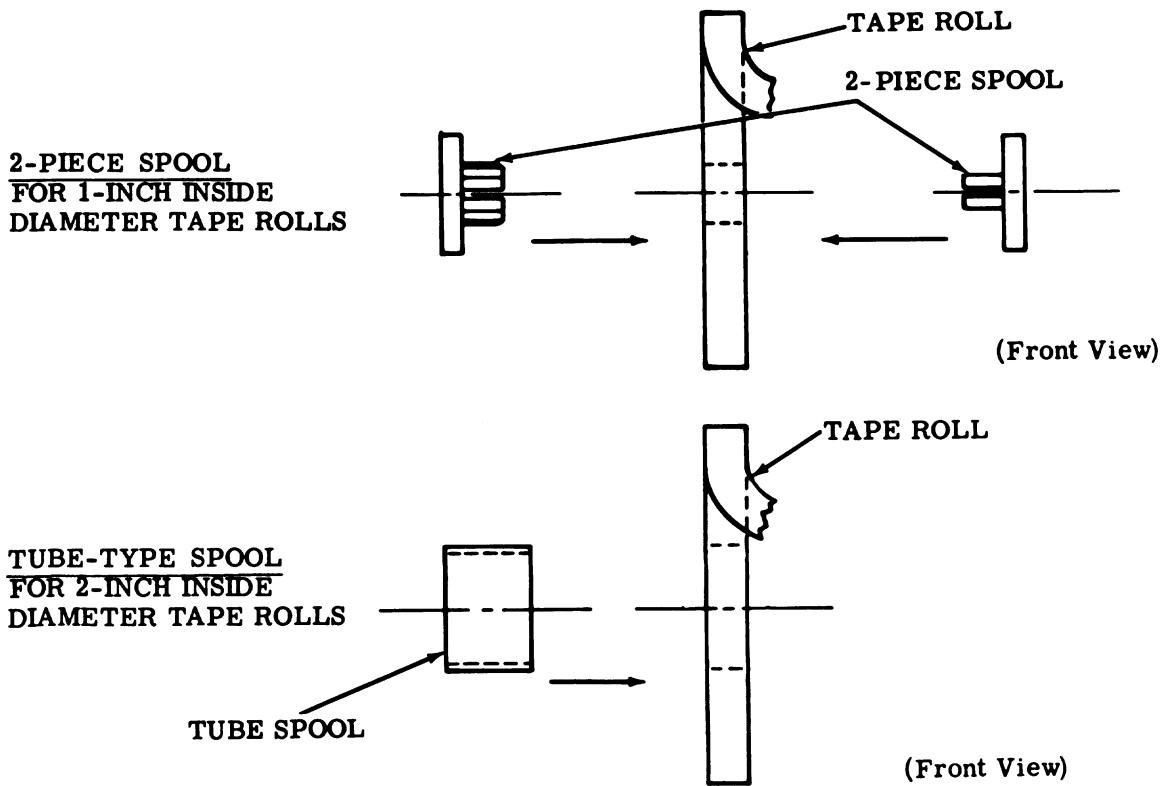

Figure 13 - Tape Roll and Tape Spool Assembly



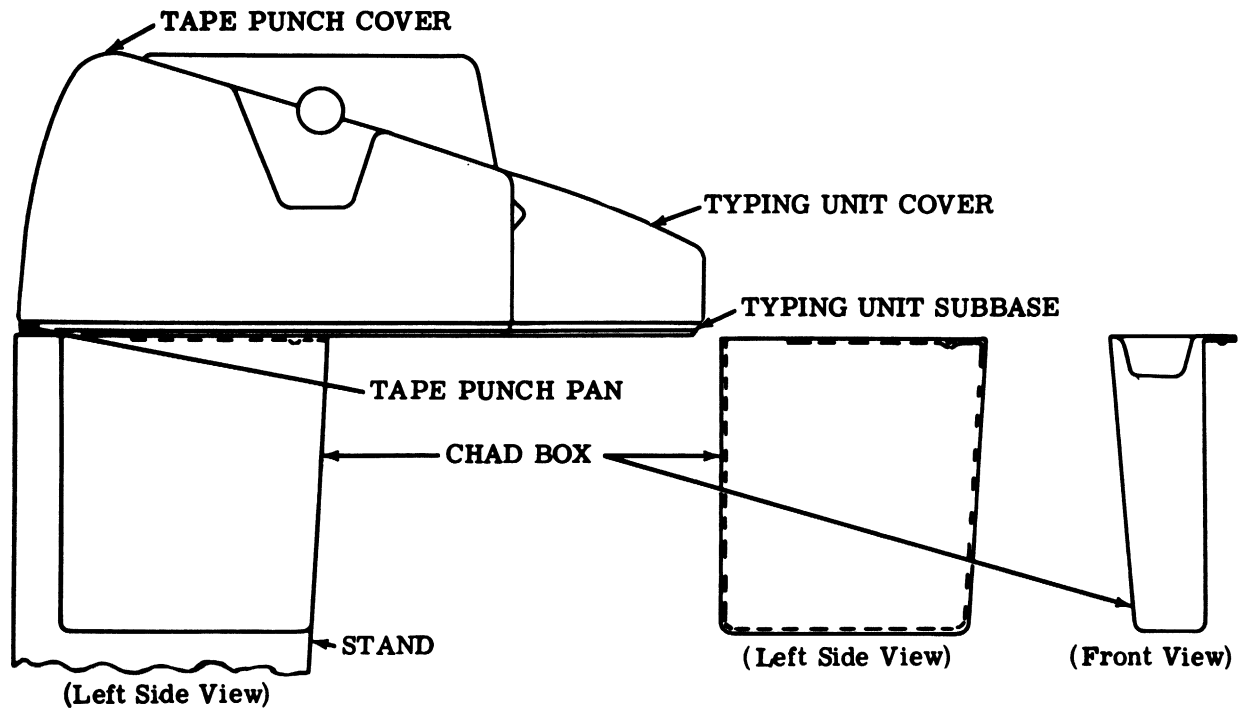

Figure 14 - Tape Punch Chad Chute Assembly

7.03 Figure 14 illustrates the chad box installation.

- (a) Assemble the chad box under the tape punch pan by inserting the back of the flanged surface between the stand and the typing unit subbase.
- (b) Push the chad box toward the rear until the bent surface located at the front of the chad box engages the stand. An embossing located on the front bottom surface of the flanged surface engages an oblong hole in the stand and holds the chad box in place.
- (c) To empty the chad box, lift the front slightly and pull the chad box toward the front until it becomes disengaged.

## 8. RESHIPMENT

8.01 If the teletypewriter set is to be shipped to another location without its cover, the following must be done to avoid damage to the typing unit.

- (a) Remove subbase and typing unit from the stand.
- (b) Remove the plug button from the forward mounting hole in the bottom of the subbase.
- (c) Secure typing unit to the base by inserting and tightening the screw and washer previously stored in the TP181104 cable clip (1.09). Do not damage the typing unit by overtightening the screw.
- (d) Store the removed plug button in the TP181104 cable clip.



33 TELETYPEWRITER SET

REMOVAL AND REPLACEMENT OF COMPONENTS

CONTENTS	PAGE
1. GENERAL . . . . .	1
2. REMOVAL AND REPLACEMENT . . .	1
COVER . . . . .	1
TYPING UNIT . . . . .	2
KEYBOARD . . . . .	2
CALL CONTROL UNIT . . . . .	4
READER . . . . .	4
PUNCH . . . . .	4

1. GENERAL

1.01 This section is issued to provide removal and replacement instructions for major components of the 33 Teletypewriter Set.

1.02 References to left, right, front, rear, etc, consider the set as viewed from the normal operating position.

1.03 The removal procedure given in this section subdivides the set into its major components. Each removal procedure is written assuming the set to be completely assembled, ie, no components previously removed. If further disassembly of the component is required, refer to the appropriate disassembly and reassembly section or the illustrated parts section which gives detailed arrangements of all parts. Where it will help in determining their location, the numbers of the parts are given in the instructions.

1.04 All tools used to remove the major components referred to in this section can be found in the 570-005-800TC standard tool section.

1.05 All damaged, worn, or distorted parts should be replaced if encountered in the removal and replacement procedure.

**CAUTION: BEFORE REMOVING COMPONENTS, REMOVE CONNECTORS FROM EXTERNAL RECEPTACLES (POWER SOURCE, DATA SET, ETC).**

2. REMOVAL AND REPLACEMENT

COVER

2.01 To remove the set cover (Figure 1), proceed as follows.

(a) Remove paper and paper roll spindle. Remove bezel, if used, on call control unit by removing screws. Remove the volume control knob, if used, or the power switch rotary knob, if used, by pulling frontward. Remove the nameplate by pulling it down and out. Remove the platen knob used on friction feed typing units by pulling it to the left. On sprocket feed typing units, remove a platen knob screw first, then remove the platen knob by pulling it to the left.

(b) Remove the four TP181141 screws from front and the three TP184085 screws from rear of typing unit cover.

Note: On Automatic Send-Receive (ASR) Teletypewriter Sets, remove the TP183112 screw from left rear corner of the tape reader cover.

(c) Gently lift the cover from the subbase and set it aside.

Note: On Automatic Send-Receive (ASR) Teletypewriter Sets, the typing unit cover, tape punch cover, and reader cover are all interconnected and they remove as one unit. If desired the three covers can then be separated from each other.

(d) To replace the cover, reverse the procedure used to remove it. Make sure that all protrusions are aligned in the holes provided.

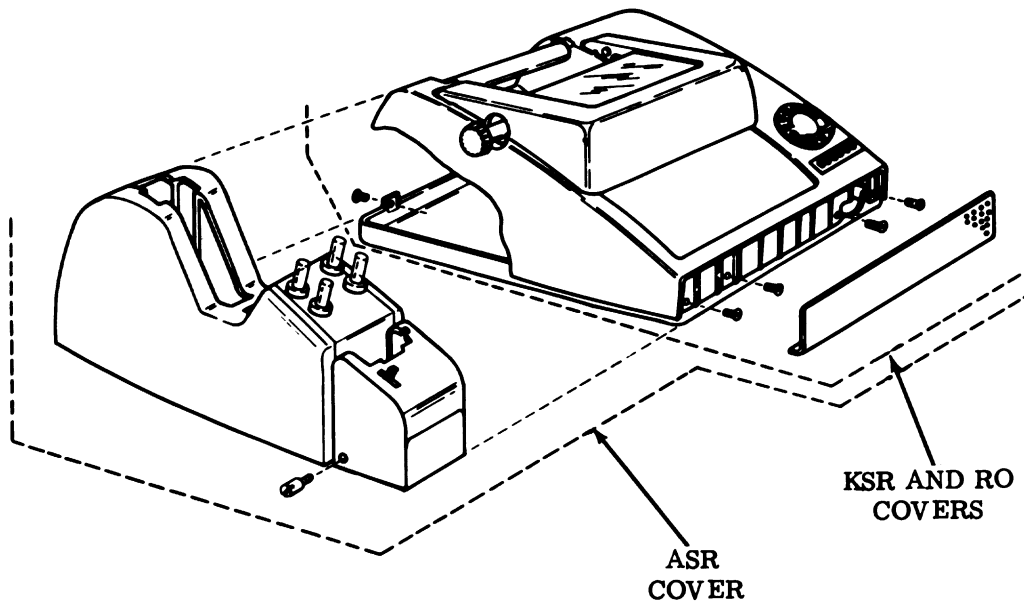

Figure 1 - Set Covers

### TYPING UNIT

2.02 To remove typing unit (Figure 2), proceed as follows.

- (a) Remove cover assembly as described in 2.01.
- (b) Remove all plugs which connect the typing unit to the call control unit. Remove ground strap from ground tab on call control unit.

Note: On ASR Sets, remove the two leads that connect to the reader cable from the contact assembly.

- (c) Insert screwdriver in slot of TP180977 H-plate and push to left against pressure of spring until plate is disengaged from universal lever. Remove H-plate.
- (d) Lift typing unit from subbase using the following procedure.

(1) Insert a screwdriver between the typing unit base casting and the subbase in the left rear of the typing unit.

(2) Using the screwdriver as a lever, lift the left rear section of the typing unit until the left hand can be placed under the unit.

(3) Grasp the extreme right side of the front carriage shaft and lift the typing unit from the subbase.

(e) To replace typing unit, reverse procedure used to remove it. Make sure that the typing unit is properly seated on rubber isolaters and that the TP180831 answer-back bellcrank is under and aligned with the HERE IS keylever. Replace plugs into proper receptacles on call control unit.

### KEYBOARD

2.03 To remove the keyboard (Figure 3), proceed as follows.

- (a) Remove cover assembly as described in 2.01.
- (b) Remove the keyboard plug from its receptacle on the call control unit.

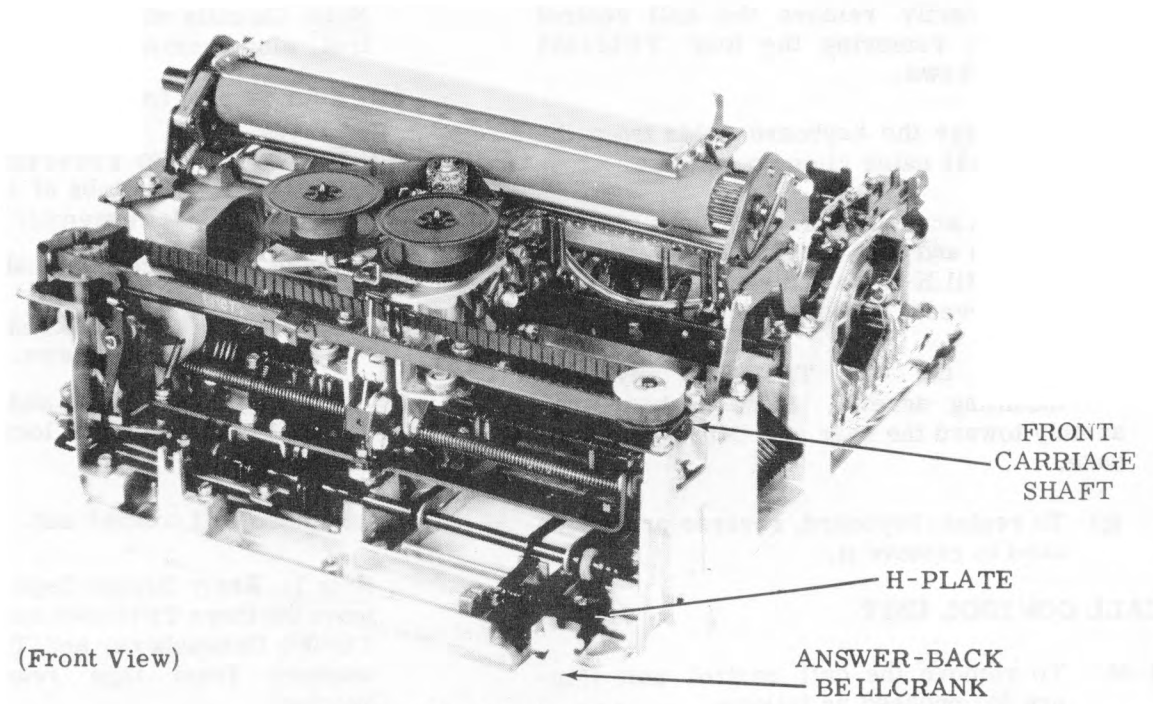

Figure 2 - Typing Unit

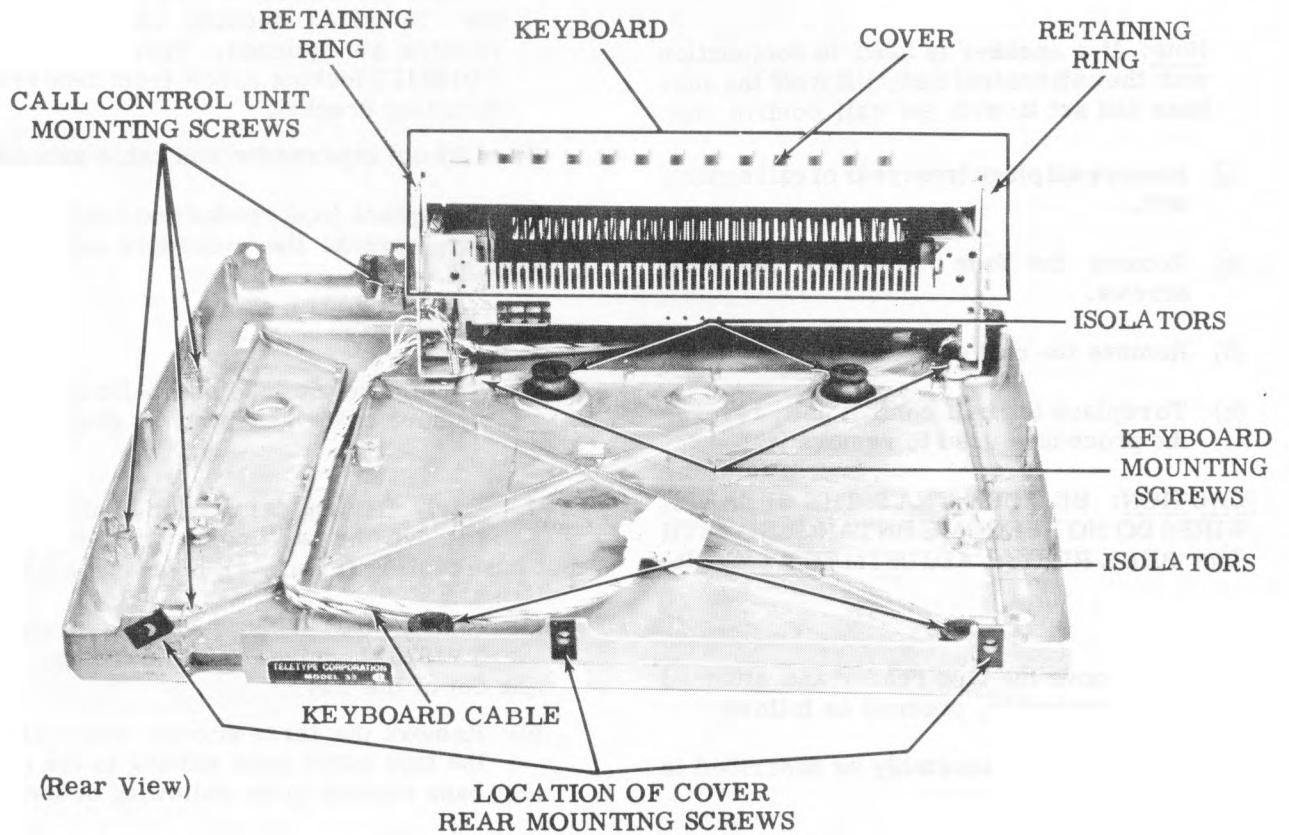

Figure 3 - Subbase With Keyboard

## SECTION 574-100-702TC

(c) Temporarily remove the call control unit by removing the four TP121551 mounting screws.

(d) Disengage the keyboard cable from the TP182531 cable clips on subbase.

(e) Insert a screwdriver in slot of TP180977 H-plate and push to left against pressure of spring until H-plate is disengaged from the universal lever. Remove the H-plate.

(f) Loosen the two TP180798 keyboard mounting screws. Slide keyboard assembly toward the rear and lift it from subbase.

(g) To replace keyboard, reverse procedure used to remove it.

### CALL CONTROL UNIT

2.04 To remove the call control unit (Figure 3), proceed as follows.

(a) Remove cover assembly as described in 2.01.

Note: If a speaker is used in conjunction with the call control unit, lift it off the subbase and set it with the call control unit.

(b) Remove all plugs from rear of call control unit.

(c) Remove the four TP121551 mounting screws.

(d) Remove the call control unit.

(e) To replace the call control unit, reverse the procedure used to remove it.

**CAUTION: BE SURE THAT THE SPEAKER WIRES DO NOT BECOME ENTANGLED WITH THE BELL RINGER ADJUSTMENT LEVER.**

### READER

2.05 To remove the tape reader and attached cable assembly, proceed as follows.

(a) Remove cover assembly as described in 2.01.

(b) Remove tape reader plug marked "6" from receptacle in back of call control unit.

Note: On units with automatic reader control, also remove plug marked "5".

(c) Remove plug from power pack.

(d) Remove the two TP182726 push-on terminals from the tabs of the tape reader feed magnet contact assembly.

(e) Remove any necessary cable clamps.

(f) Remove the four TP121551 call control bracket mounting screws.

(g) Lift call control unit and remove tape reader cable which is located under the call control unit.

(h) Replace call control unit.

Note 1: Early Design Tape Readers: Remove the three TP181244 mounting screws, TP7002 flatwashers, and TP124177 lockwashers from tape reader mounting bracket.

Note 2: Late Design Tape Readers: First remove the TP119651 retaining ring from the TP183117 locking screw on tape readers so equipped. Then, remove the TP183117 locking screw from tape reader mounting bracket.

(i) Lift out tape reader and cable assembly.

(j) To replace tape reader and cable assembly, reverse the procedure used to remove it.

### PUNCH

2.06 To remove the tape punch lid assembly, remove cover assembly as described in 2.01.

2.07 Early Design (Aluminum Casting): To remove the tape punch from the typing unit base casting (Figure 4), proceed as follows.

(a) Unhook the TP3864 spring from the TP182894 drive link and rotate drive link out of the way.

(b) Remove the three screws which secure the tape punch base casting to the typing unit base casting in the following order:

First, the TP181246 screw.  
Second, the rear TP182891.  
Finally, the most forward TP182891 screw.

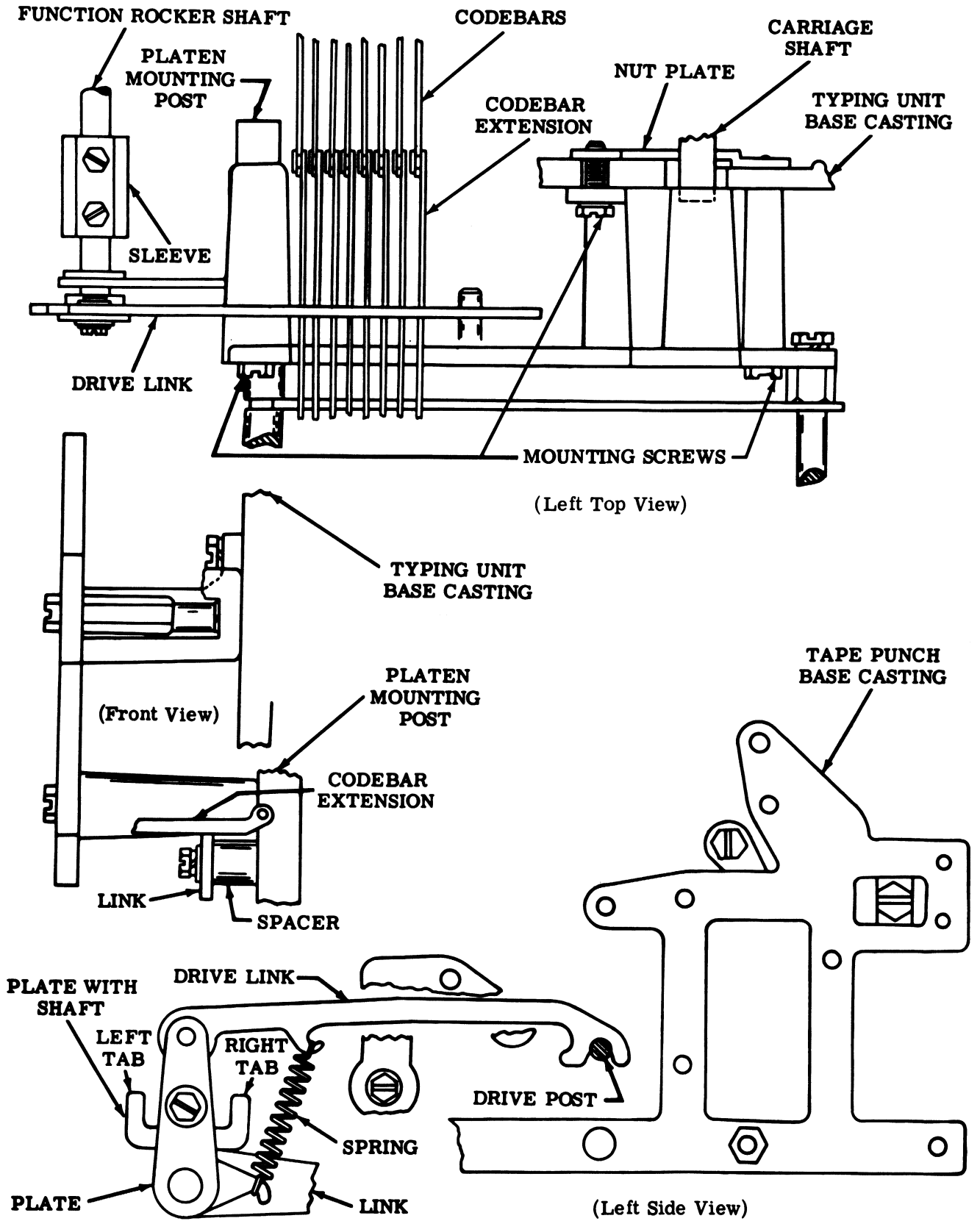

Figure 4 - Tape Punch (Early Design)

(c) Remove the TP182805 nut plate from the inside surface of the front wall of the typing unit base casting.

(d) Remove the codebar extensions from their respective codebar slots while removing the tape punch base casting from the carriage shaft.

(e) To replace the tape punch to the typing unit base casting, reverse the procedure used to remove it. Prior to replacing the tape punch to the left side of the typing unit base casting, manually set up the typing unit so that all codebars are in the marking position.

(a) Unhook the TP3864 spring from the TP182894 drive link and rotate drive link out of the way.

(b) Remove the two TP181241 bracket connecting screws.

(c) Remove the TP181242 screw that holds the TP182252 post to the TP182256 plate.

(d) Remove the codebar extensions from their respective codebar slots while also removing the tape punch from the typing unit.

(e) To replace the tape punch to the typing unit base casting, reverse the procedure used to remove it. Prior to replacing the tape punch to the left side of the typing unit base casting, manually set up the typing unit so that all codebars are in the marking position.

2.08 Late Design (Sheet Steel Frame): To remove the tape punch from the typing unit base casting (Figure 5), proceed as follows.

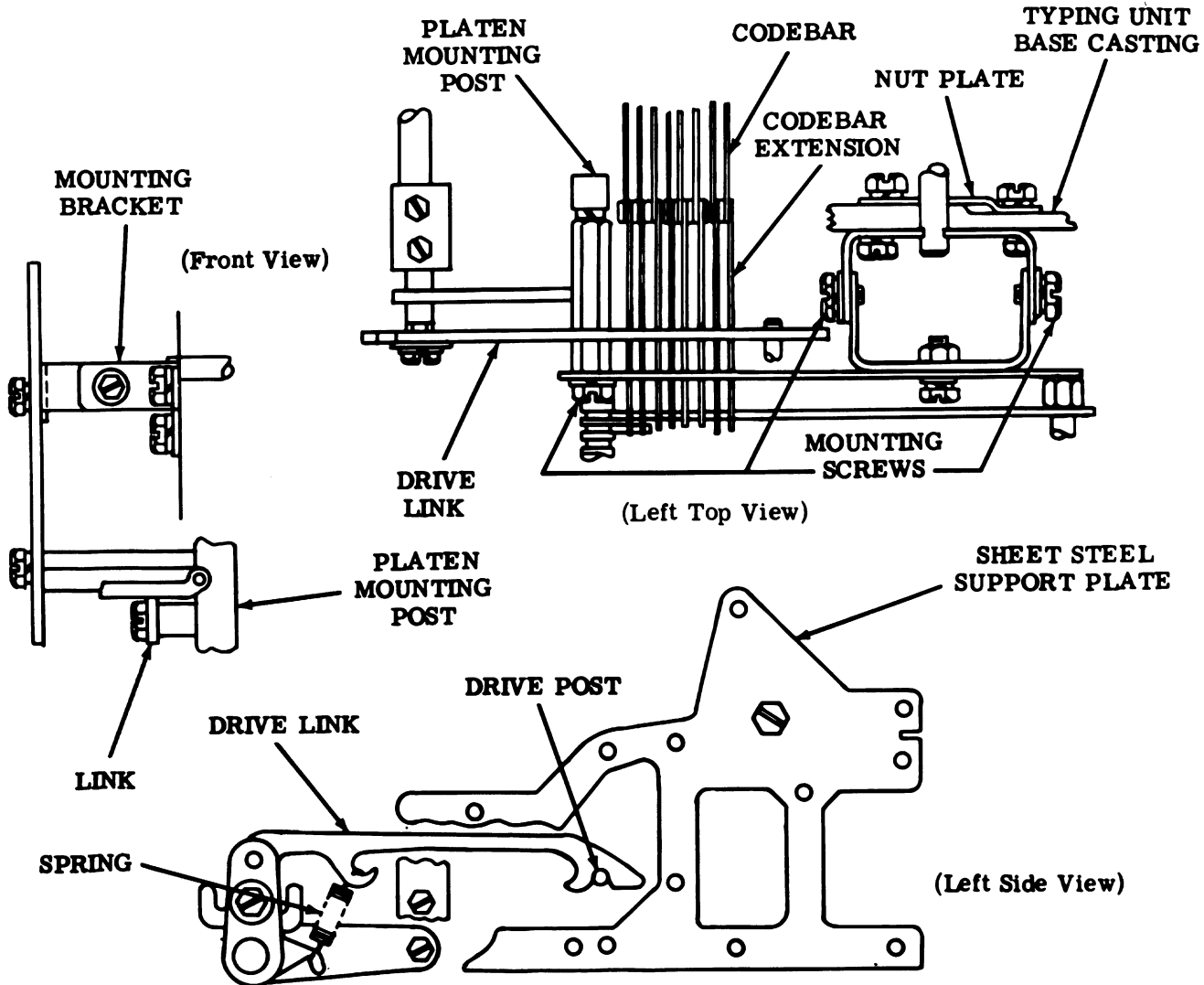

Figure 5 - Tape Punch (Late Design)



33 KEYBOARD

GENERAL DESCRIPTION AND PRINCIPLES OF OPERATION

CONTENTS	PAGE
1. GENERAL . . . . .	1
2. TECHNICAL DATA . . . . .	1
3. ASCII CODE . . . . .	3
4. OUTLINE OF OPERATION . . . . .	4
5. DETAILED OPERATION . . . . .	4
A. Codebar Mechanism . . . . .	4
B. Universal Codebar Mechanism . . . . .	5
C. Keyboard Contact Mechanism . . . . .	6
D. Line Break . . . . .	7
E. Repeat . . . . .	7
F. HERE IS . . . . .	7
G. Keyboard — Typing Unit Interface . . . . .	7
H. Nonparity Operation . . . . .	7
I. Parity Operation . . . . .	9

1. GENERAL

1.01 This section is reissued to provide a general description of the 33 keyboard. Information on the 32 keyboard presented in Issue 1 has been omitted and is covered in Section 574-171-100TC. A general updating of the 33 keyboard description is being presented in this section, so that marginal arrows ordinarily used to indicate changes have been omitted.

1.02 Both the nonparity and parity keyboards are covered in this section.

1.03 The 33 nonparity and parity keyboards are electromechanical apparatus used to mechanically select and electrically transmit the ASCII (USA Standard Code for Information Interchange) code.

1.04 The functional difference between the nonparity and parity keyboards is in the control of the eighth level pulse:

- (a) With nonparity keyboards the eighth pulse is always marking.
- (b) With parity keyboards the eighth pulse changes so that an even number of marking pulses is transmitted for every character.

Note: For further details on the ASCII code and transmission principles refer to the Typing Unit, Section 574-122-100TC.

1.05 References to left, right, front, rear, etc consider the keyboard as viewed by the operator.

1.06 In the illustrations fixed pivots are solid black, and floating pivots — those mounted on parts that move — are crosshatched.

**CAUTION: DISCONNECT ALL POWER FROM THE KEYBOARD PRIOR TO INSPECTION.**

2. TECHNICAL DATA

2.01 Dimensions and Weight (Approximate)

Height . . . . .	5 inches
Width . . . . .	12-1/2 inches
Depth . . . . .	5 inches
Weight . . . . .	4-1/2 pounds

2.02 Electrical

Long loops . . . . .	0.015 to 0.070 ampere, 48 to 240 volts dc inductive
Short loops . . . . .	0.058 to 0.072 ampere, (local operation) 16 to 22 volts dc resistive

2.03 Transmission Code

Level . . . . .	8
-----------------	---

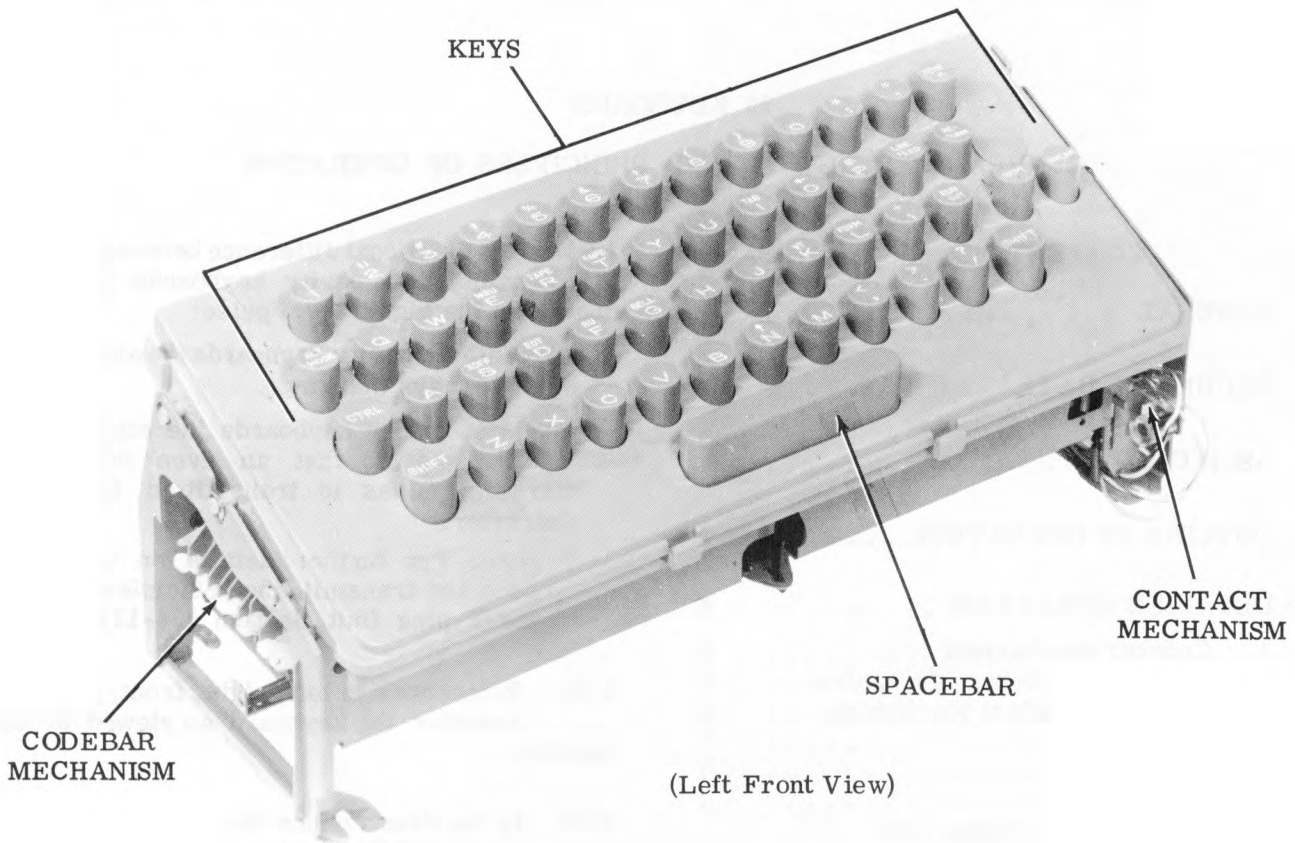

Figure 1 - Nonparity Keyboard

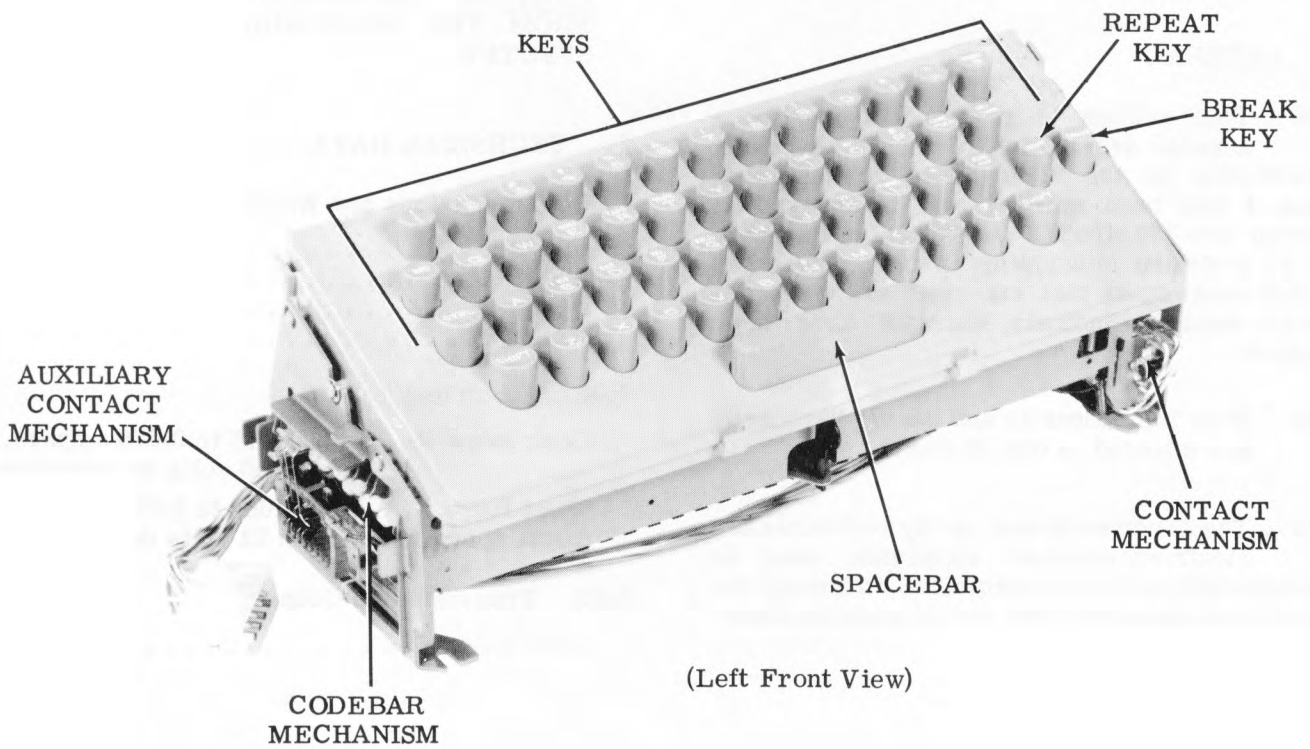
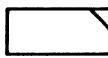
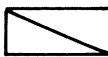

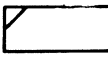
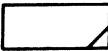

Figure 2 - Parity Keyboard

				b7	0	0	0	0	1	1	1	1
				b6	0	0	1	1	0	0	1	1
				b5	0	1	0	1	0	1	0	1
b4	b3	b2	b1									
0	0	0	0	NUL	DLE	SP	0	@	P			
0	0	0	1	SOH	DC1	!	1	A	Q			
0	0	1	0	STX	DC2	"	2	B	R			
0	0	1	1	ETX	DC3	#	3	C	S			
0	1	0	0	EOT	DC4	\$	4	D	T			
0	1	0	1	ENQ	NAK	%	5	E	U			
0	1	1	0	ACK	SYN	&	6	F	V			
0	1	1	1	BEL	ETB	/	7	G	W			
1	0	0	0	BS	CAN	(	8	H	X			
1	0	0	1	HT	EM	)	9	I	Y			
1	0	1	0	LF	SUB	*	:	J	Z			
1	0	1	1	VT	ESC Note 6	+	;	K	[			
1	1	0	0	FF	FS	,	<	L	\			Note 2
1	1	0	1	CR	GS	-	=	M	]			Note 5
1	1	1	0	SO	RS	.	>	N	^			Note 7
1	1	1	1	SI	US	/	?	O	_			DEL

- NUL - Null
- SOH - Start of Heading
- STX - Start of Text
- ETX - End of Text
- EOT - End of Transmission
- ENQ - Enquiry
- ACK - Acknowledge
- BEL - Bell
- BS - Backspace
- HT - Horizontal Tabulation
- LF - Line Feed
- VT - Vertical Tabulation
- FF - Form Feed
- CR - Carriage Return
- SO - Shift Out
- SI - Shift In
- DLE - Data Link Escape
- DC - Device Control
- NAK - Negative Acknowledge
- SYN - Synchronous Idle
- ETB - End of Transmission Block
- CAN - Cancel
- EM - End of Medium
- SUB - Substitute
- ESC - Escape
- FS - File Separator
- GS - Group Separator
- RS - Record Separator
- US - Unit Separator
- SP - Space
- DEL - Delete

-  LOCKED OUT BY CONTROL
-  NOT APPLICABLE TO 33 EQUIPMENT
-  SHIFT CHARACTERS  
┌5 └8
-  CONTROL CHARACTERS  
└7 ┌8
-  LOCKED OUT BY SHIFT

Note 1: 1 = Mark, 0 = Space.

Note 2: Cannot be generated from keyboard.

Note 3: Blocks not indicating SHIFT or CTRL characters contain primary key characters.

Note 4: Filled-in corners or blocks indicate 8th pulse marking (in nonparity units, 8th pulse is always marking).

Note 5: This code can be generated on model 33 nonparity keyboards by depressing the ALT MODE key.

Note 6: The ESC control function may be generated by depressing the ESC key or by simultaneously depressing the K, SHIFT, and CTRL keys.

Note 7: The UK 803 generates ESC for this code combination.

Figure 3 - 33 Application of ASCII Code

### 3. ASCII CODE

3.01 The 33 keyboard operates according to the ASCII code (ASCII - USA Standard Code for Information Interchange). Figure 3

shows the 1967 version of the code used in 33 keyboards. The SHIFT and CONTROL characters, their associated keytop operation lock-outs, and parity operation are also illustrated.

4. OUTLINE OF OPERATION

4.01 Transmission of messages is accomplished by an operator selectively depressing the keys and spacebar of the keyboard in the same manner as in typing. The downward movement of each key or the spacebar is translated by a codebar mechanism into a mechanical arrangement corresponding to the code combination representing the character on the keytop. The mechanical arrangements set up the code combinations in a set of keyboard contacts, and, by parallel output, the code combinations are transmitted to a distributor mechanism. A universal mechanism trips a distributor clutch, and a distributor mechanism then translates the parallel output from the keyboard contacts into corresponding start-stop signal for application to the transmission facilities.

5. DETAILED OPERATION

A. Codebar Mechanism

5.01 The codebar mechanism is illustrated in Figure 4.

5.02 For each level in the code there is a codebar mechanism which consists of a front codebar, a rear codebar, a tie link, and two T-levers. Thus in the 33 keyboard there are 8 pairs of codebars whose function is to set up 8 pairs of contacts in a coded arrangement representing the key depressed. The codebar mechanism also contains a shift mechanism (Figure 8) which consists of a front and rear codebar, a tie link, and two (three in parity keyboards) T-levers. Both the parity and nonparity keyboards contain a control blocking mechanism operated by the CTRL key. It consists of a tie link and two T-levers. The order in which the codebar mechanism is arranged varies, but the following may be considered typical. Thus from front to rear:

- Nonparity Keyboard UNIV, 1, SHIFT, 2, 3, 4, 5, 6, 7, CTRL
- Parity Keyboard UNIV, 1, 8, 2, 3, 4, 5, 6, 7, SHIFT, CTRL

5.03 The codebars have slots in their top edges which codes them so they are selectively depressed by the keys' keylevers. Each mechanism has a marking and a spacing

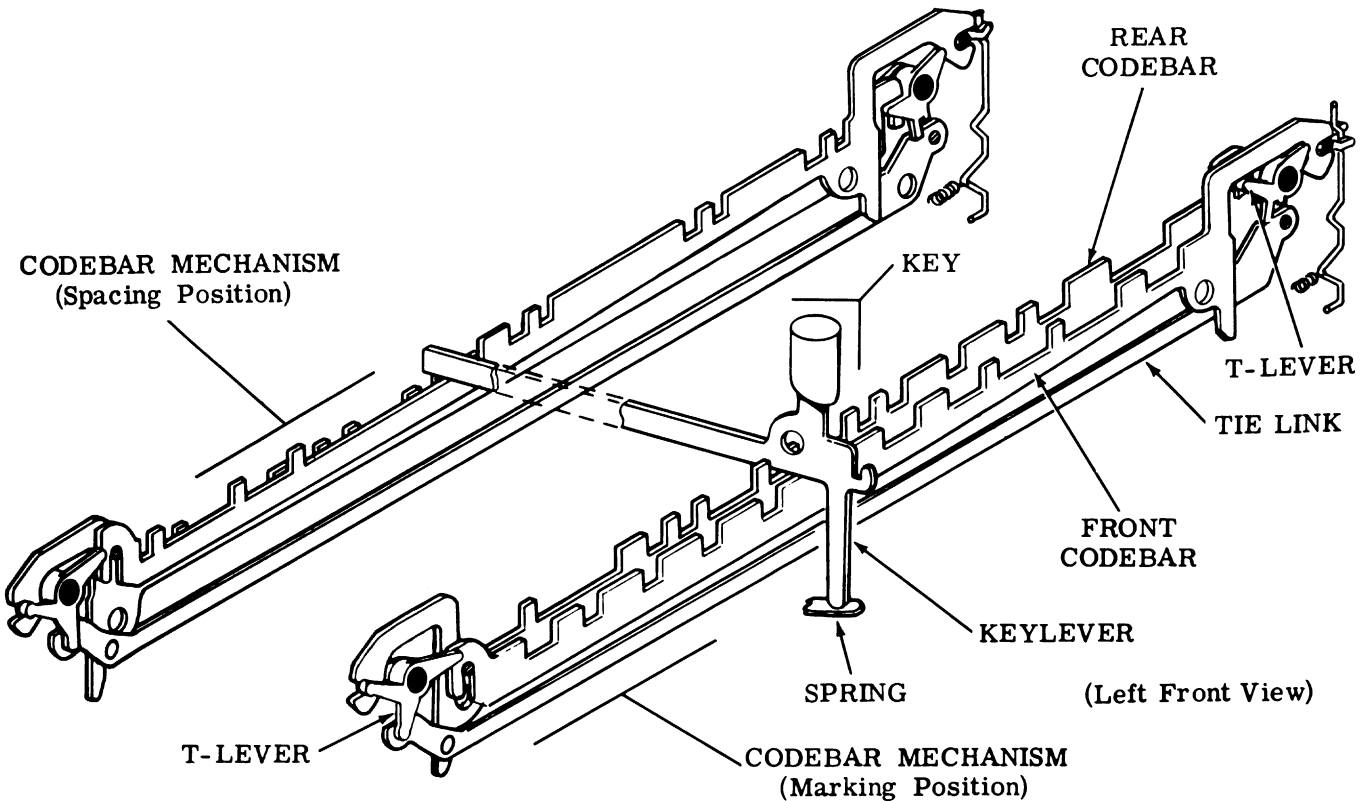

Figure 4 - Codebar Mechanism

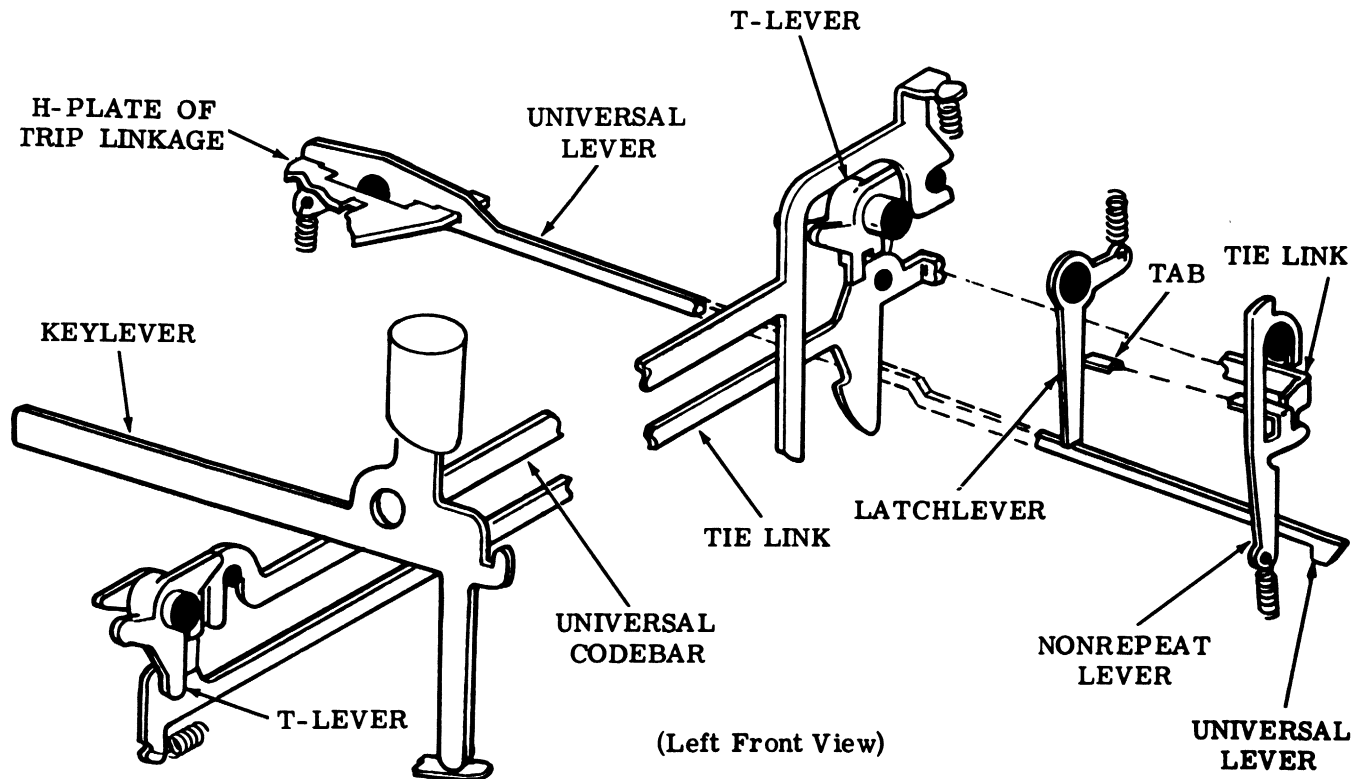

Figure 5 - Universal Codebar Mechanism

position. In the marking position, the front codebar is down, the rear codebar is up, and the right T-lever is in the clockwise position. The spacing position is the opposite: front codebar up, rear codebar down, and right T-lever in counterclockwise position.

5.04 The two codebars in each mechanism are coded so that where one has a slot the other is solid. When a character key is depressed, it is returned to its up position by a leaf spring on the underside of the keyboard. However, the code combination set up in the codebars is retained until another key is depressed. When another key is depressed, only the mechanism whose code elements differ from those of the preceding combination are operated.

5.05 As an example assume that the letter E has been transmitted. The E code combination 1-3---78 remains in the codebar mechanisms. Now assume that the I (1--4--78) key is depressed. Its keylever encounters a slot in the rear codebar of the no. 1, 7, and 8 codebar mechanisms. Thus these mechanisms remain marking. In the case of the no. 2, 5, and 6 codebar mechanisms, the keylever encounters a

slot in the front codebar, and they remain spacing. In the case of the no. 3 codebar mechanism, the keylever encounters the solid portion of the rear codebar and shifts it to its spacing position. In a similar manner, the keylever encounters the solid portion of the front codebar of the no. 4 codebar mechanism and shifts it to the marking position.

5.06 Since each code combination is different and is locked in the codebar mechanisms, the complementary coding of the codebars serves as an interlock for the keylevers. When one keylever is depressed, another cannot be depressed because it will be blocked by the solid portion of one or more codebars.

#### B. Universal Codebar Mechanism

5.07 The universal codebar mechanism is illustrated in Figure 5.

5.08 As a keylever nears the bottom of its travel, it depresses a codebar which is part of the universal codebar mechanism. The codebar, in turn, causes associated T-levers to

## SECTION 574-121-100TC

pivot and a tie link to move to the left. After some free movement, the tie link encounters a tab on a nonrepeat lever and pivots the latter to the left. The tab, in turn, pivots a latchlever which releases a universal lever. Under spring pressure, the universal lever moves up and lifts the nonrepeat lever so that its tab is moved from between the universal tie link and the latchlever. Under spring pressure, the latchlever and nonrepeat lever move back to the right to their unoperated position.

5.09 In its up position, the universal lever locks the right intelligence T-levers in the positions setup by the keylever, permits a contact bail to pivot to its down position and, through a trip linkage, trips the distributor clutch. Near the end of the distributor cycle, the trip linkage moves the universal lever back to its down position where it is latched by the latchlever.

5.10 Should the keylever remain depressed beyond the end of the distributor cycle, when the universal lever moves to its down position, the nonrepeat lever under spring tension moves down until it hangs up on the top of the universal tie link which is still in its left position. When the keylever is finally released, the tie link moves back to the right and permits the nonrepeat lever to move all the way down so that its tab is again between the tie link and the latchlever. The trip mechanism operates in this way to prevent the distributor clutch from being retripped when a keylever is held down.

### C. Keyboard Contact Mechanism

5.11 The keyboard contact mechanism is illustrated in Figure 6.

5.12 The codebar mechanisms set up the code combinations in a set of keyboard contacts. A contact wire is associated with each right T-lever, excluding the universal. In the stop condition of the keyboard, a contact bail is held in its up position by the universal lever. The contact bail holds the contact wires to the right, away from the T-levers.

5.13 When a keylever is depressed, a code combination is set up in the codebar mechanisms. The universal lever moves to its up position and permits the contact bail to pivot under spring tension to its down position. The contact wires associated with the T-levers that

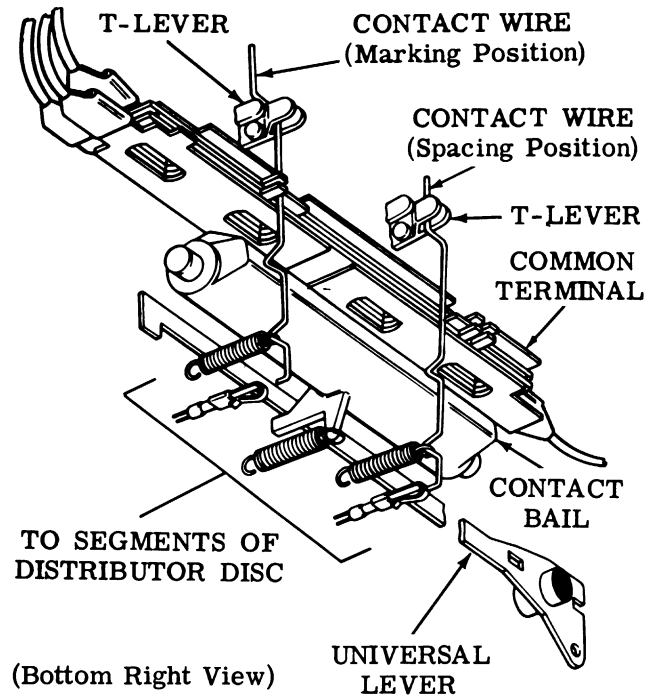

Figure 6 - Keyboard Contact Mechanism

are in the marking (clockwise) position are permitted, under spring tension, to move to the left against a common terminal. Those associated with the T-levers that are in the spacing (counterclockwise) position are held to the right away from the terminal. For example, if the I code combination (1--4--78) is set up in the codebar mechanism, the no. 1, 4, 7, and 8 contact wires are against the common terminal. Similarly the no. 2, 3, 5, and 6 contact wires are away from the common terminal.

**Note:** When the universal lever is at the peak of its upward travel, it locks the T-levers in their assumed positions (Figure 7). This eliminates the possible loss of a marking or spacing pulse as a result of blocking T-levers repositioning during keyboard transmission.

5.14 The distributor mechanism converts these positions to start-stop signals. Near the end of the distributor cycle, the universal lever moves back to its down position and pivots the bail to its up position. The bail in turn cams the contact wires back to the right and holds them there in the stop position.

#### D. Line Break

5.15 When the BREAK key is depressed, it pivots a T-lever which opens the break contact. This action opens the signal line until the BREAK key is released.

#### E. Repeat

5.16 To repeat the transmission of a character, its keylever is held down along with the REPT keylever. The latter holds the nonrepeat lever down where its tab remains between the tie link and the latchlever (Figure 5). The latchlever is held in its left position and does not latch the universal lever at the end of the cycle. The universal lever thus moves up and trips the distributor clutch causing the character to be rétransmitted as long as the REPT key is depressed.

#### F. HERE IS

5.17 When the HERE IS key is depressed, its keylever pivots linkages in the typing unit which in turn activate the local answer-back.

#### G. Keyboard — Typing Unit Interface

5.18 The H-plate (Figure 5) serves as the mechanical interface between the keyboard and the typing unit.

5.19 After a key is depressed and the keyboard contacts are positioned, the universal lever moves to its up position. This upward movement is transferred by the H-plate to the distributor clutch linkage, to trip the distributor clutch. Near the end of the distributor cycle the trip linkage, through the H-plate, resets the universal lever back to its lower position.

#### H. Nonparity Operation

5.20 Figure 9 is a simplified schematic of the signal wiring for the nonparity keyboard.

5.21 Intelligence transmitted from the nonparity keyboard is that of the ASCII (USA Standard Code for Information Interchange) code system. The keyboard contains two SHIFT keys and one CTRL (Control) key (Figure 8). The control key, utilizing a tie link and T-levers, operates a contact wire in the contact mecha-

nism. The SHIFT key is used to generate the code combinations for printing characters appearing on the upper keytop (eg \$ above the 4). The CTRL key is used to generate the codes for the nonprinting control characters appearing on the upper keytops (eg EOT above the D). Simultaneous use of both CTRL and SHIFT keys allows access to special control functions, such as NULL. In every case, the SHIFT and/or CTRL keys must be held down while the appropriate character key is depressed.

5.22 The SHIFT key inverts the no. 5 code element on all 33 keyboards. If the element is normally marking, it makes it spacing; if the element is normally spacing, it makes it marking. It does this by two 2-headed T-levers, one at the shift position, and one at the no. 5 position, each of which operates two contact wires, alternately opening one and closing the other. As shown in Figure 9, in the spacing condition, the "c" contact associated with the no. 5 T-lever is open, and the "d" contact is closed. In its unoperated position, the "a" contact associated with the SHIFT T-lever is closed, and the "b" contact is open. For example, if the "4" key alone is depressed, the code combination for "4" (--3-56-8) is set up in the keyboard contacts and subsequently transmitted. In this case, the 2-headed no. 5 T-lever holds the "c" contact closed and the "d" contact open, resulting in a marking no. 5 code element. (The signal path is through the stop distributor disc segment, the common terminal, the closed "c"

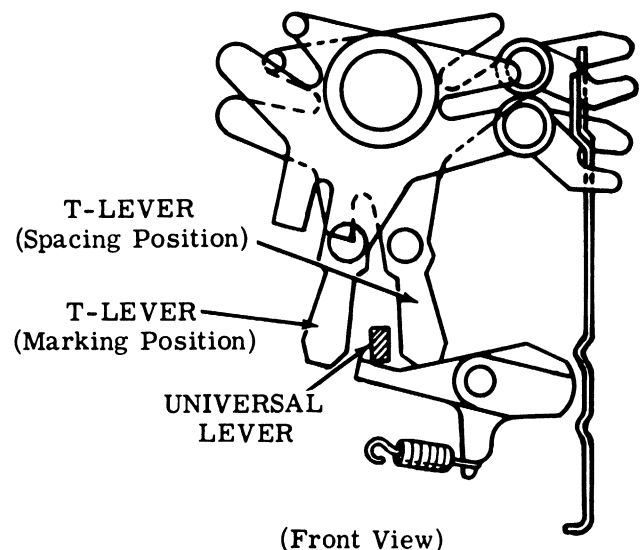

Figure 7 - T-Lever Positioning

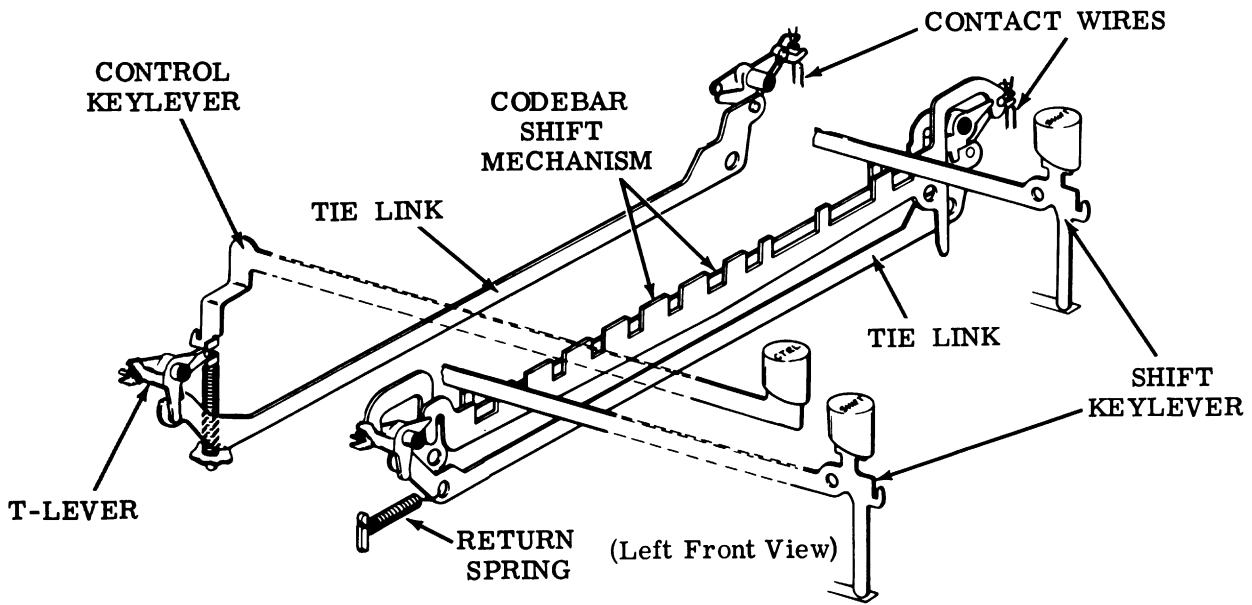
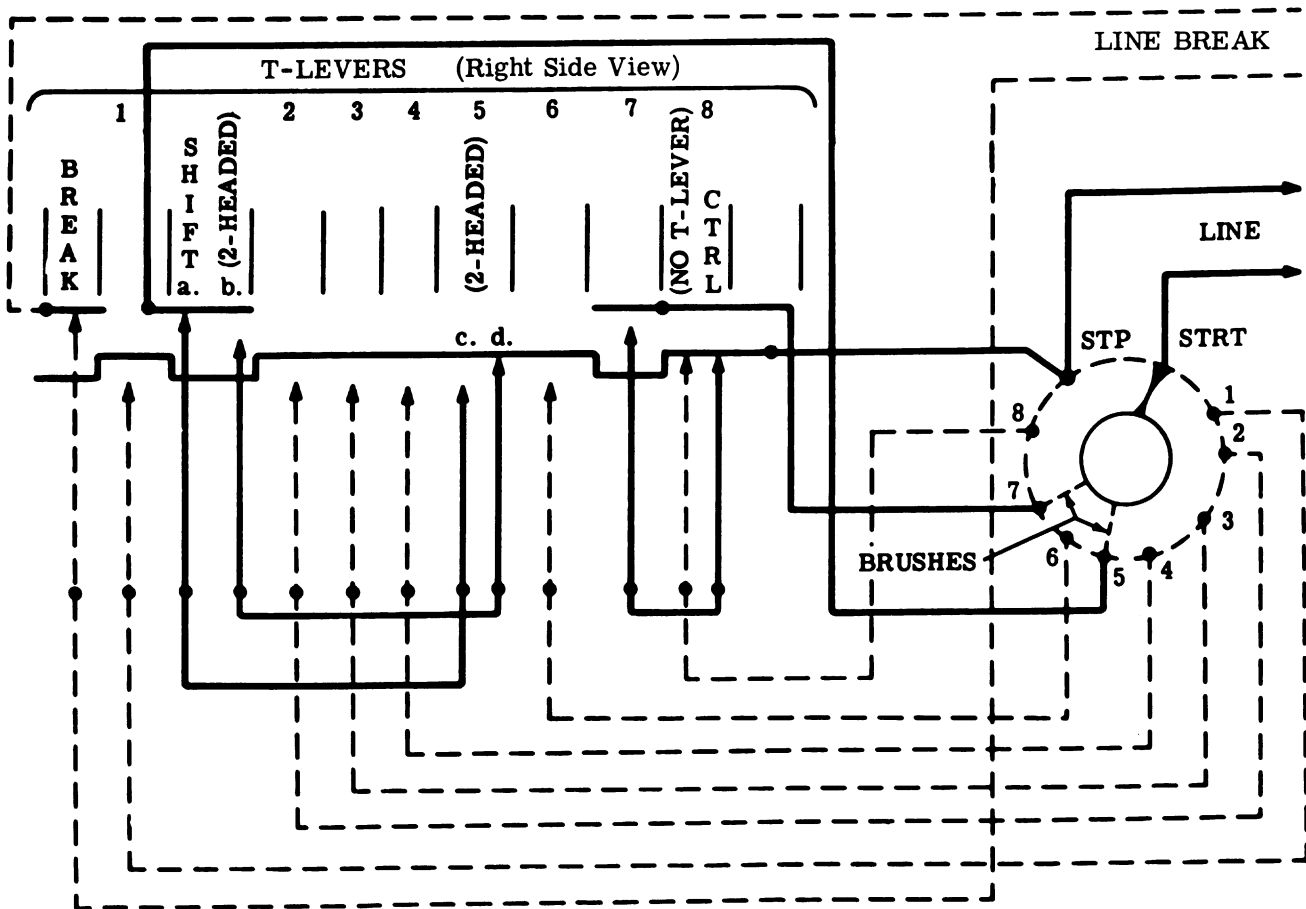

Figure 8 - SHIFT and CTRL Mechanisms — Nonparity Keyboard



Note: Intelligence contacts shown in spacing position.  
Shift contacts shown in unoperated position.

Figure 9 - Contact Schematic — Nonparity Keyboard



contact, the closed "a" contact, the no. 5 distributor disc segment, the brushes, the inner distributor disc, and the start distributor disc segment, as shown in Figure 9.)

5.23 If the "4" key is depressed with the SHIFT key, the same condition is setup in the keyboard contacts, except that the 2-headed shift T-lever holds the "a" contact open and the "b" contact closed and thus opens the signal circuit. This results in the no. 5 code element being spacing rather than marking, and the code combination for "\$" (--3--6-8) being transmitted.

5.24 If the "N" key alone is depressed, the code combination for "N" (-234--78) is set by the codebars and subsequently transmitted to the line. In this case, the 2-headed no. 5 T-lever holds the "c" contact open and the "d" contact closed. On the other hand, if the "N" key is depressed with the SHIFT key, the same condition is set up in the keyboard contacts as before, except that the SHIFT key opens the "a" contact and closes the "b" contact and thus closes the signal circuit. This results in the no. 5 code element being marking rather than spacing and the code combination for ^ (-2345-78) being transmitted.

5.25 The CTRL key converts the no. 7 code element from marking to spacing. For example, if the "E" key alone is depressed, the "E" code combination (1-3---78) is set up in the keyboard contacts and subsequently transmitted. (The path of the current for the marking no. 7 code element is through the stop distributor disc segment, the common terminal, the closed control contact, the closed no. 7 contact, the no. 7 distributor disc segment, the brushes, the inner distributor disc, and the start distributor disc segment.) If the "E" key is held down with the CTRL key, the same condition as before is set up in the contacts, except that the control T-lever opens the control contact and thus breaks the signal circuit. This results in the no. 7 code element being spacing and the code combination for "ENQ" (1-3----8) being transmitted.

## I. Parity Operation

5.26 The parity keyboard facilities are similar to those of the nonparity keyboard. The functional difference between parity and nonparity keyboards is in the control of the 8th level pulse.

5.27 These differences include the adding of a codebar mechanism to generate binary information for the eighth intelligence element. In addition, the SHIFT key operates an expanded shift codebar mechanism (Figure 10) which operates three 2-headed T-levers, two 2-headed T-levers control contact wires at the contact mechanism, and one 2-headed T-lever controls contact wires at an added auxiliary contact mechanism (Figure 10). Also, the CTRL key directly operates a 2-headed T-lever which controls contact wires at the auxiliary contact mechanism.

5.28 Figure 10 illustrates how the CTRL key acts to mechanically block all keys which normally have the no. 6 code element marking. When the CTRL key is depressed, a tab on the keylever engages the rear codebar of the no. 6 codebar mechanism and forces it into its spacing position. Simultaneously, the front codebar moves up, and the solid portions on it block the keylevers of all characters which normally have their no. 6 code element marking. This blocking action will prevent false characters from being transmitted.

Note: Keyboard lockout (keylever downward travel blocked by codebar mechanism) may occur if SHIFT or CTRL keytops are only partially depressed when the universal codebar mechanism is activated. To clear the lockout, again depress and release the SHIFT or CTRL keytops and, if necessary, also depress and release the specific primary keytop with which the lockout occurred.

5.29 The SHIFT key inverts the no. 5 and no. 8 code elements on the parity keyboard. If either element is normally marking, it makes it spacing; if either element is spacing, it makes it marking. This is accomplished by several 2-headed T-levers — one at the no. 5 position, two at the shift position on the contact mechanism, and one at the shift position on the auxiliary contact mechanism. Each 2-headed T-lever operates two contact wires, alternately opening one and closing the other. As shown in Figure 11 in the spacing condition, the "c" contact associated with the no. 5 T-lever and the "e" contact associated with the no. 8 T-lever are open, and the "d" and "f" contacts, respectively, are closed. In their unoperated positions, with the universal lever latched, the "b", "h", and "m" contacts associated with shift T-levers are open, while the "g" and "n" contacts are closed.

Note: The "a" contact is open on early design units equipped with the TP180043 shift marking contact wires and closed on late de-

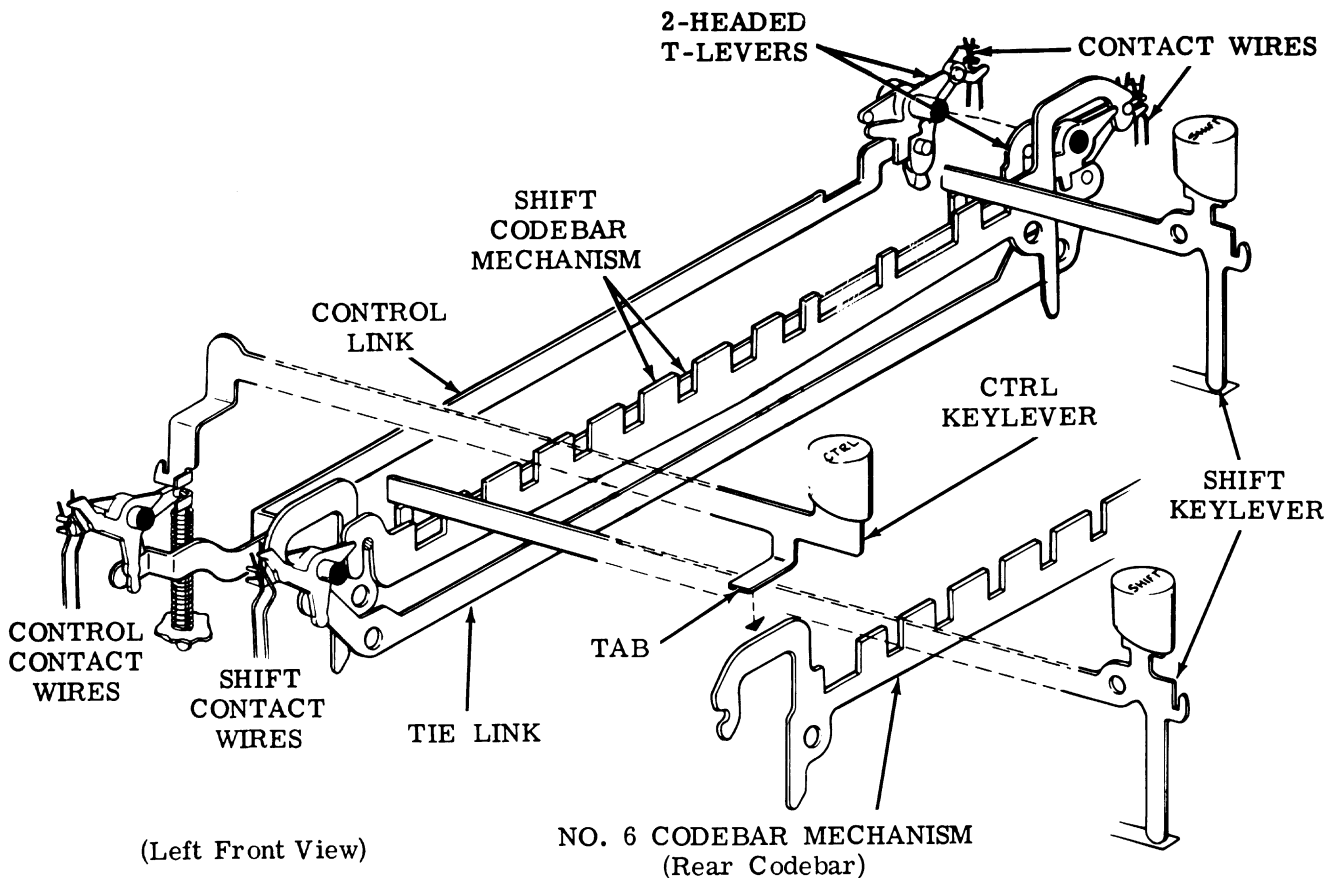

Figure 10 - SHIFT and CTRL Key Operation — Parity Keyboard

sign units equipped with the TP186417 marking contact wires.

When the universal lever is tripped and the contact bail is pivoted, the "a" contact will be in the closed condition unless the SHIFT key is depressed, which will open the "a" contact and close the "b" contact. In addition, the "h" and "m" contacts will close and the "g" and "n" contacts will open. For example, if the "4" key alone is depressed, the code combination for "4" (--3-56-8) is set up in the keyboard contacts and subsequently transmitted. In this case, the 2-headed no. 5 T-lever holds the "c" contact closed and the "d" contact open, resulting in a marking no. 5 code element. The current path is from the connector, through the common terminal, the closed "c" contact, the closed "a" contact and terminal, and back to the connector. Since the no. 8 code element is to be marking, the 2-headed no. 8 T-lever holds the "e" contact closed and the "f" contact open. The current path is from the connector, through a terminal

and the "e" contact, through the closed "n" contact and terminal, through the closed "j" contact and terminal, and back to the connector.

5.30 If the "4" key is depressed with the SHIFT key, the same condition is set up in the keyboard contacts, except 2-headed T-levers hold the "a", "g", and "n" contacts open and the "b", "h", and "m" contacts closed. Thus, the current paths for the no. 5 and no. 8 code elements are open. This results in the no. 5 and no. 8 code elements being spacing rather than marking, and the code combination for \$ (--3--6--) is transmitted.

5.31 If the "N" key alone is depressed, the code combination for "N" (-234--7-) is set up by the codebars and subsequently transmitted to the line. In this case, 2-headed T-levers at the no. 5 and no. 8 positions, respectively, hold the "c" and "e" contacts open and the "d" and "f" contacts closed. On the other hand, if the "N" key is depressed with the

SHIFT key, the same condition is set up in the keyboard contacts as before, except that T-levers associated with the shift position open the "a", "g", and "n" contacts and close the "b", "h", and "m" contacts. Thus current paths for the no. 5 and no. 8 code elements are closed. This results in the no. 5 and no. 8 code elements being marking rather than spacing, and the code combination for ^ (-2345-78) is transmitted.

5.32 The CTRL key converts the no. 7 code elements from marking to spacing and inverts the no. 8 code element. When the CTRL key is operated, the no. 7 code element will always be spacing. Also, the no. 8 code element will be made spacing if it is normally marking;

it will be made marking if it is normally spacing. For example, if the "D" key alone is depressed, the code combination (--3---7-) is set up in the keyboard contacts and subsequently transmitted. The current path for the marking no. 7 code element is from the connector, through the terminal and the closed no. 7 contact, through the closed "j" contact and terminal, and to the connector. Since the no. 8 code element is to be spacing, the 2-headed no. 8 T-lever holds the "e" contact open and the "f" contact closed, and there is no current path. If the "D" key is held down with the CTRL key, the same condition as before is setup in the contacts, except the 2-headed control T-lever opens the "j" contact and closes the "k" contact. This breaks the

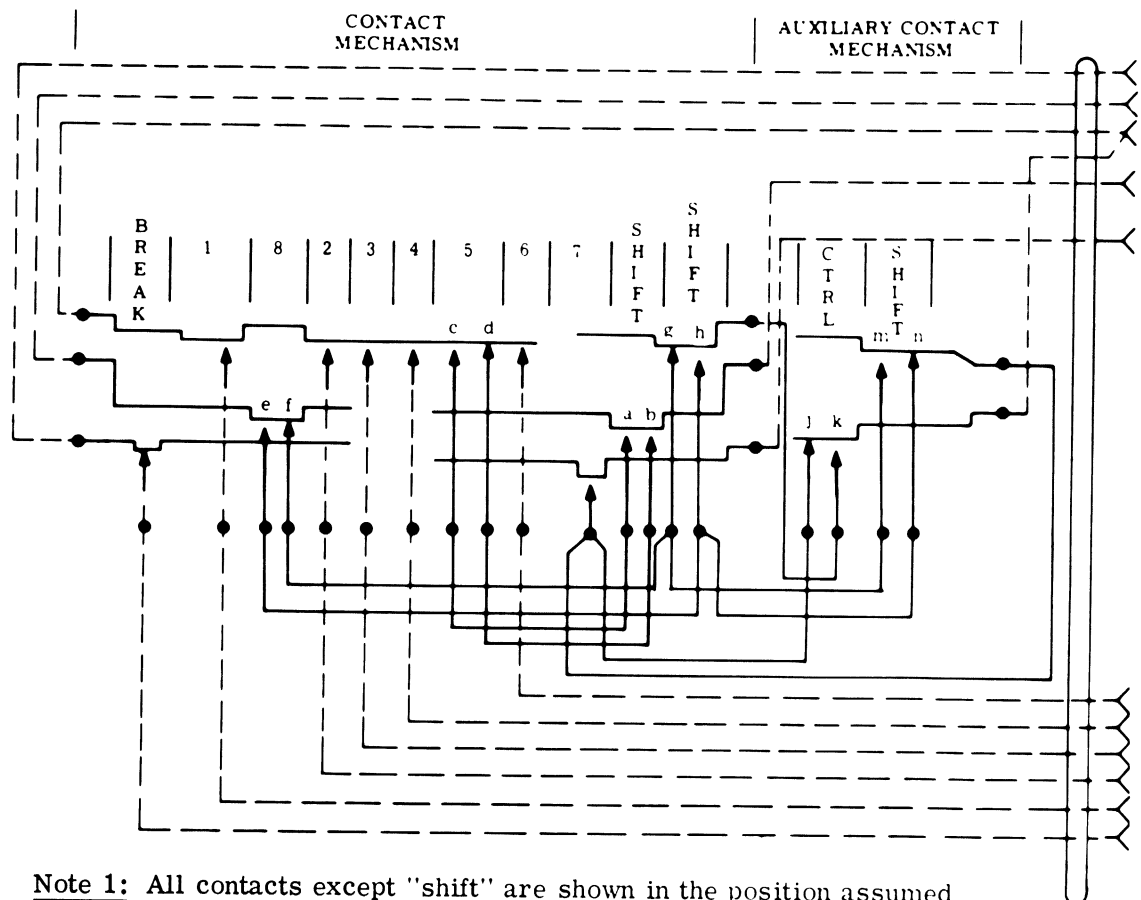

**Note 1:** All contacts except "shift" are shown in the position assumed when T-levers are in their counterclockwise position with universal lever latched.

**Note 2:** The "a" contact is open on early design units equipped with the TP180043 shift marking contact wires and closed on late design units equipped with the TP186417 marking contact wires.

Figure 11 - Contact Schematic — Parity Keyboard

## SECTION 574-121-100TC

current path through the no. 7 contact, but closes the path through the "f" contact of the 2-headed no. 8 T-lever. The current path for the no. 8 code element is from the connector, through the terminal and closed "f" contact, through the closed "g" contact and terminal,

through the closed "k" contact and terminal, and to the connector. This operation results in the no. 7 code element spacing and the no. 8 code element being marking. Thus, the code combination for "EOT" (--3----8) is transmitted.

33 KEYBOARD

LUBRICATION

CONTENTS	PAGE
1. GENERAL . . . . .	1
2. BASIC UNIT . . . . .	2
Auxiliary contact block . . . . .	4
Codebar mechanism . . . . .	5
Contact block . . . . .	4
CTRL keylever . . . . .	4
HERE IS, BREAK, and REPT keylevers . . . . .	3
Keyboard . . . . .	2
Keylevers . . . . .	3
Latchlever hooks . . . . .	5
Numeric keyboard (cover removed) . .	6
Numeric keylevers . . . . .	7
Reset bail . . . . .	5
Spacebar . . . . .	3
SPACE, BLOCK, and O keylevers . .	7
Universal lever . . . . .	6

1. GENERAL

1.01 This section provides lubrication requirements for the 33 keyboard. It is reissued to provide exclusive eight level keyboard coverage and incorporate engineering changes and additions. Since this is a general revision, marginal arrows used to indicate changes are omitted.

1.02 The general lubrication areas are illustrated by photographs. The specific points to receive lubricant are indicated on line drawings with appropriate textual instructions. The line drawings and textual instructions follow a photograph and are keyed to the photograph by paragraph numbers.

1.03 Thoroughly lubricate the keyboard, but avoid overlubrication that might permit the lubricant to drip or be thrown onto adjacent parts.

1.04 Lubricate the keyboard before placing it into service or prior to storage. After a short period of service, relubricate it to make sure no areas have been missed. Thereafter, lubricate the keyboard at regular intervals as indicated:

<u>Operating Speed</u> (Words per Minute)	<u>Lubrication</u> <u>Interval</u>
100	500 hours* or 6 months**

\*Station set operating hours.

\*\*Whichever comes first.

1.05 The textual instructions that accompany each line drawing consist of abbreviated directions, specific lubrication points, and parts affected. The meanings of the abbreviated directions (symbols) are given below:

<u>Symbol</u>	<u>Meaning</u>
D	Keep dry -- no lubricant permitted.
O	Oil (KS7470).
G	Apply thin coat of grease (KS7471).

1.06 References to left, right, front, or rear, etc, consider the keyboard to be viewed from a position where the spacebar faces up and the contact mechanism is located to the viewer's right.

**CAUTION: DO NOT USE ALCOHOL, MINERAL SPIRITS, OR OTHER SOLVENTS TO CLEAN PLASTIC PARTS OR PARTS WITH PROTECTIVE-DECORATIVE FINISHES. NORMALLY, A SOFT, DRY CLOTH SHOULD BE USED TO REMOVE DUST, OIL, GREASE, OR OTHERWISE CLEAN PARTS OR SUBASSEMBLIES. IF NECESSARY, A SOFT CLOTH**

SECTION 574-121-701TC

DAMPENED WITH SOAP OR MILD DETERGENT MAY BE USED. RINSE WITH A SOFT, DAMP CLOTH AND BUFF WITH A SOFT, DRY CLOTH.

1.07 Materials needed for lubrication are listed in Section 570-005-800TC.

1.08 Disassembly and reassembly instructions are given in Section 574-121-702TC.

**CAUTION: REMOVE ALL ELECTRICAL POWER FROM UNIT BEFORE LUBRICATION OR DISASSEMBLY.**

2. BASIC UNIT

2.01 Keyboard

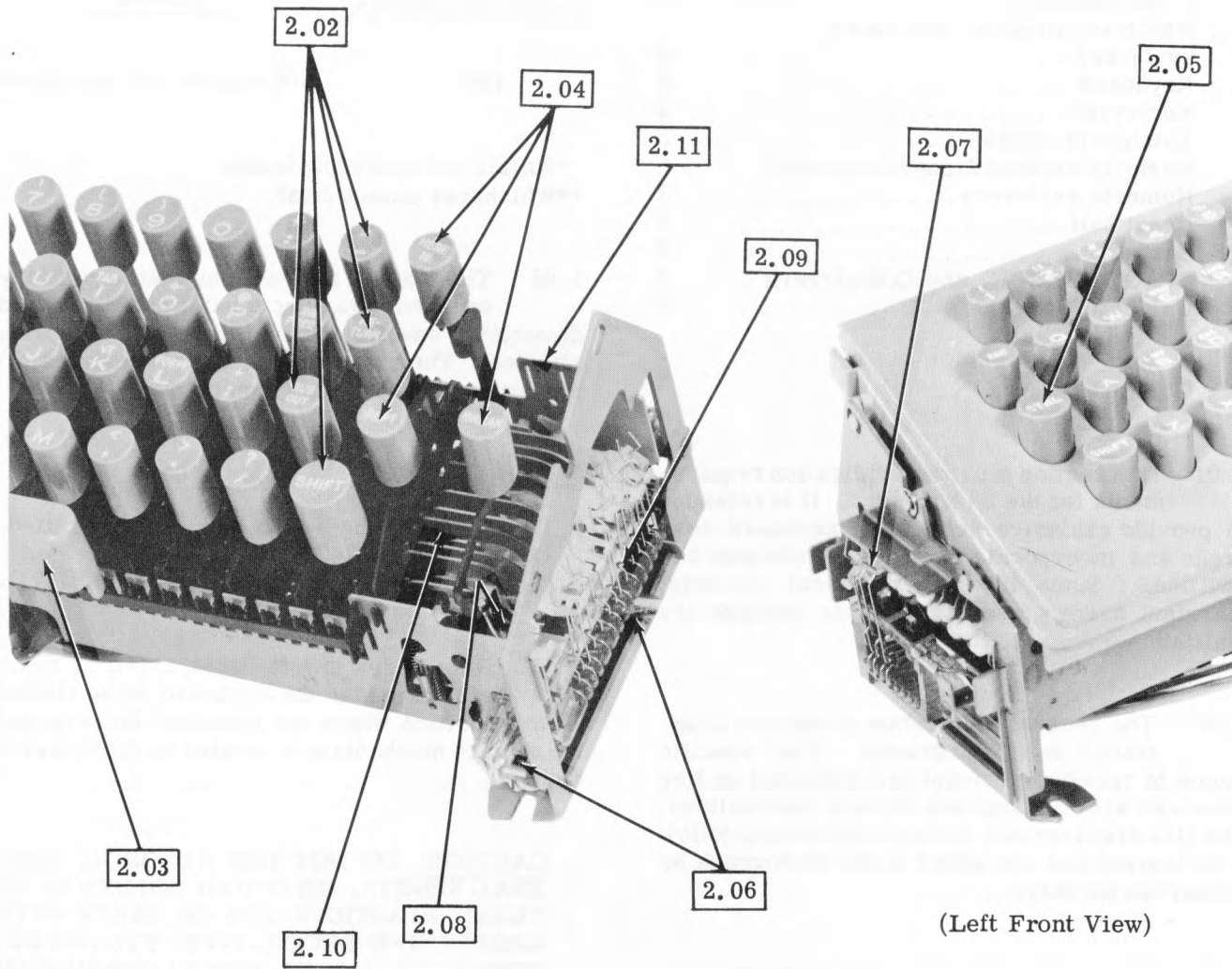

2.02 Keylevers

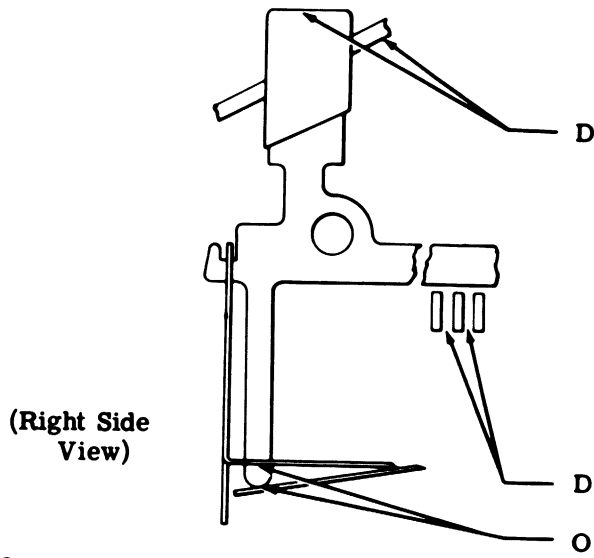

(Right Side View)

Top Surface

Keytops and Keyboard Cover

Areas Between Bars

Codebars

Contact Surface

Keylever Springs

2.03 Spacebar

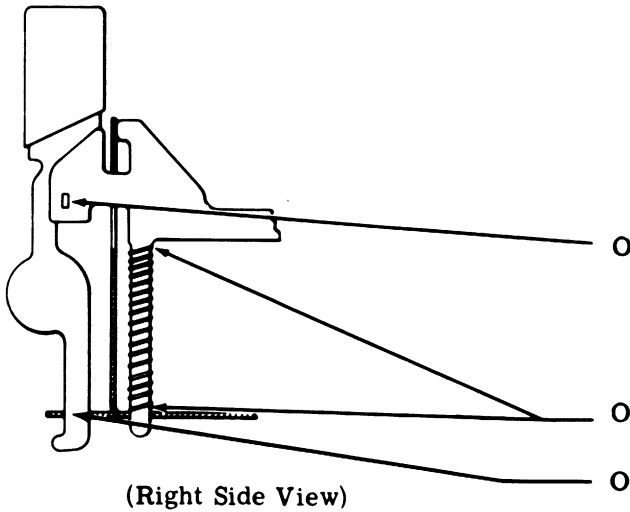

(Right Side View)

Contact Surfaces (5)

Space Lever

Seat (Each End)

Springs (2)

Sliding Surfaces

Space Lever

2.04 HERE IS, BREAK, and REPT Keylevers

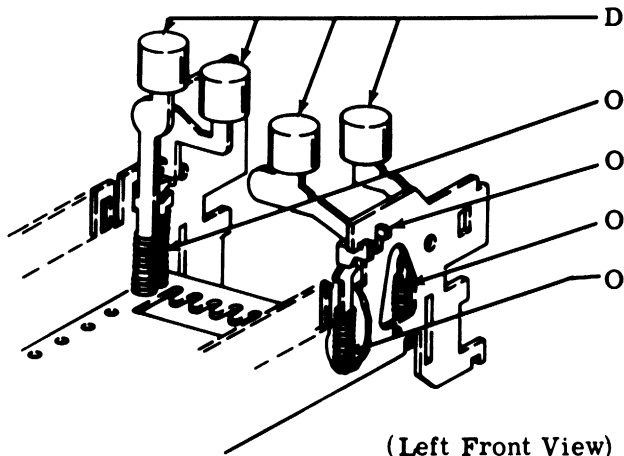

(Left Front View)

Top Surface

Keytops

Seat (Each End)

Springs

Contact Surfaces

Keylevers

Seat (Each End)

Spring

Seat (Each End)

Spring

SECTION 574-121-701TC

2.05 CTRL Keylever

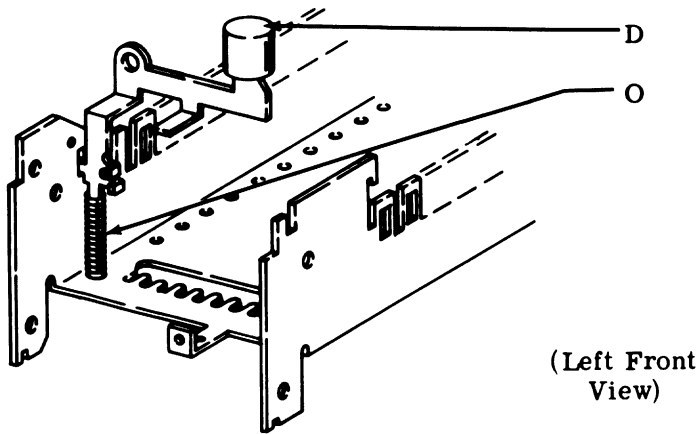

D	Top Surface	Keytop
O	Seat (Each End)	Spring

(Left Front View)

2.06 Contact Block

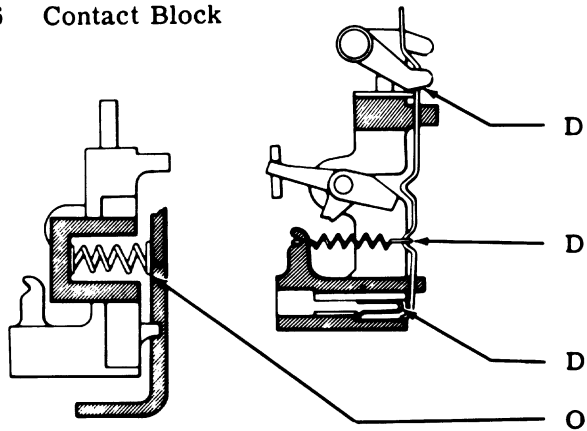

D	Contact Surface	Contact Wires
D	Springs	Contact Wires
D	Contact Surface	Contact Wires
O	Seat	Springs (2)

(Front Views)

**CAUTION: DO NOT CLEAN THE KEYBOARD CONTACT BLOCK WITH ALCOHOL, MINERAL SPIRITS, OR OTHER SOLVENTS.**

2.07 Auxiliary Contact Block

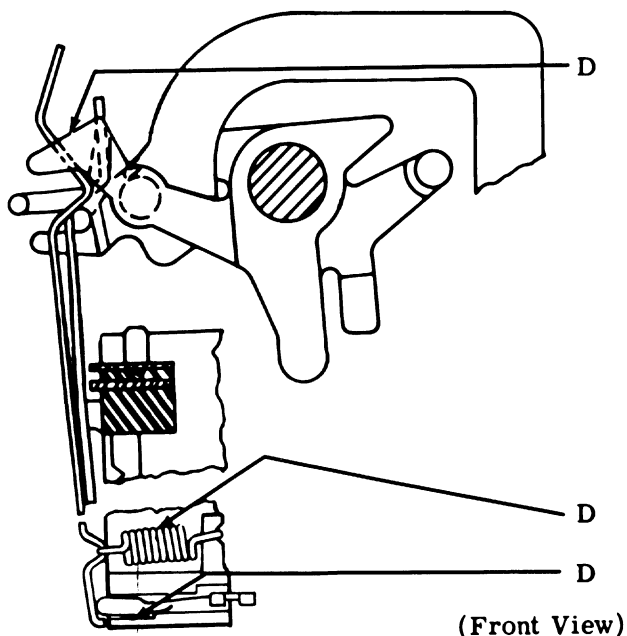

D	Contact Surfaces	Contact Wires
D	Springs	Contact Wires
D	Contact Surface	Contact Wires

(Front View)



2.08 Latchlever Hooks

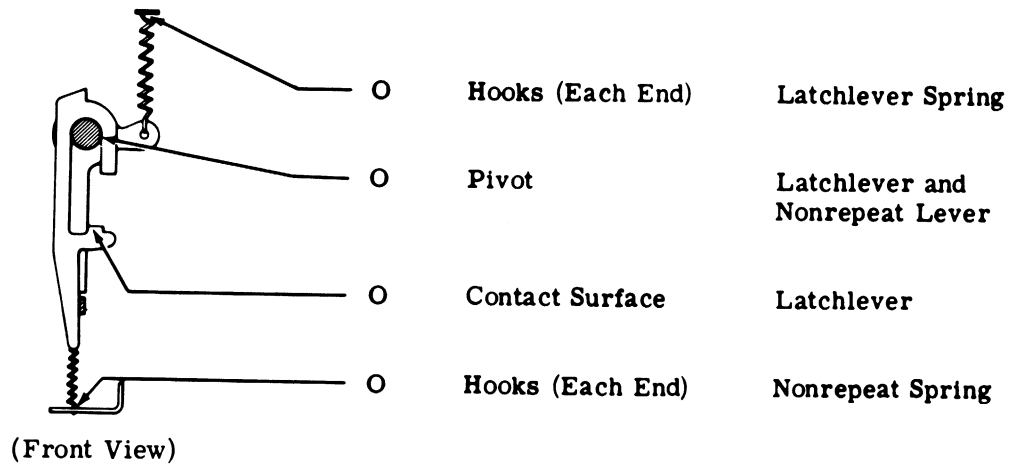

2.09 Reset Bail

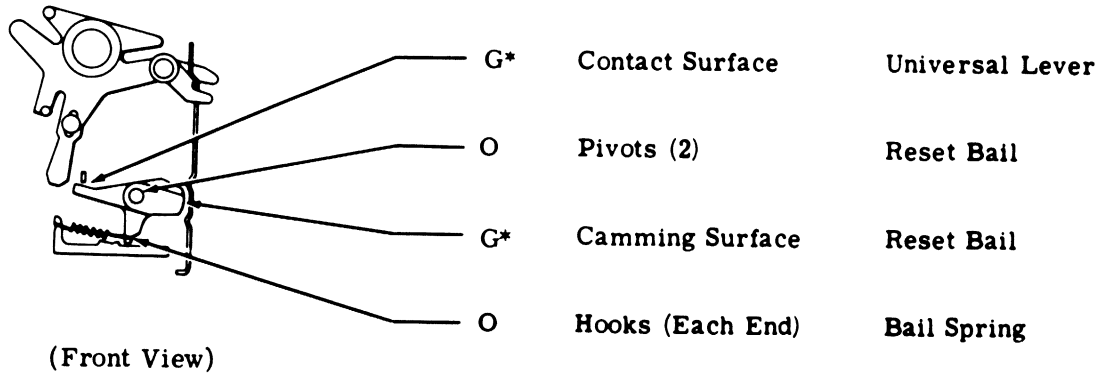

\*At 1500 hour lubrication intervals, apply a coat of thoroughly mixed 50 percent KS7470 oil and 50 percent KS7471 grease.

2.10 Codebar Mechanism

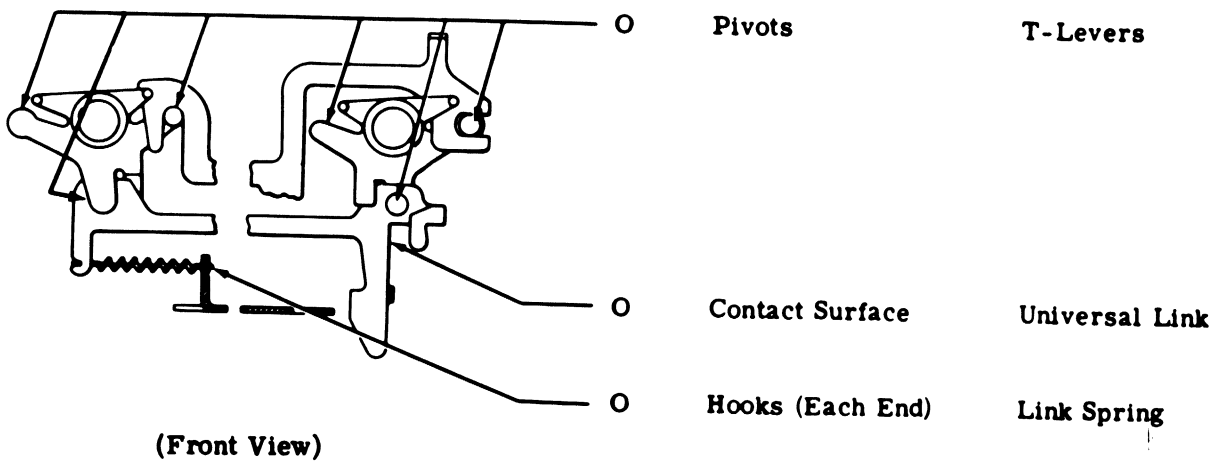

SECTION 574-121-701TC

2.11 Universal Lever

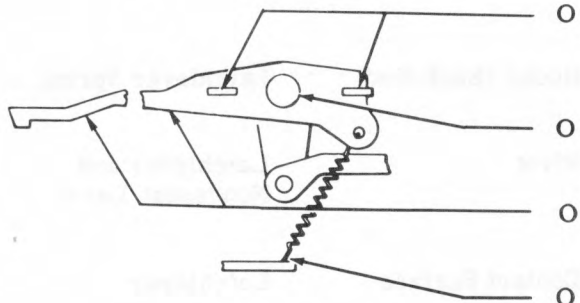

(Right Side View)

- |   |                   |                 |
|---|-------------------|-----------------|
| O | Engaging Tabs     | H-Lever         |
| O | Pivot             | Universal Lever |
| O | Engaging Surfaces | Universal Lever |
| O | Hooks (Each End)  | Spring          |

2.12 Numeric Keyboard (Cover Removed)

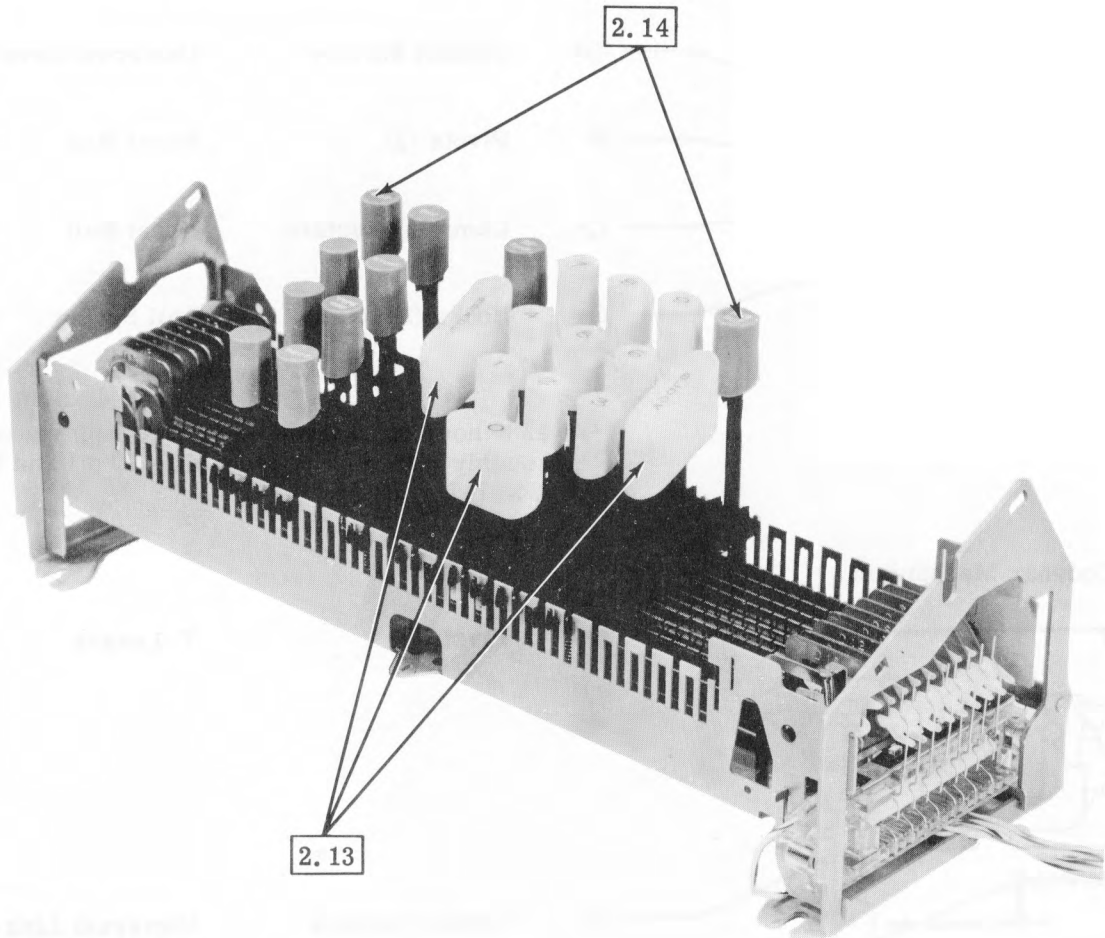

(Right Front View)

**2.13 SPACE, BLOCK, and O Keylevers**

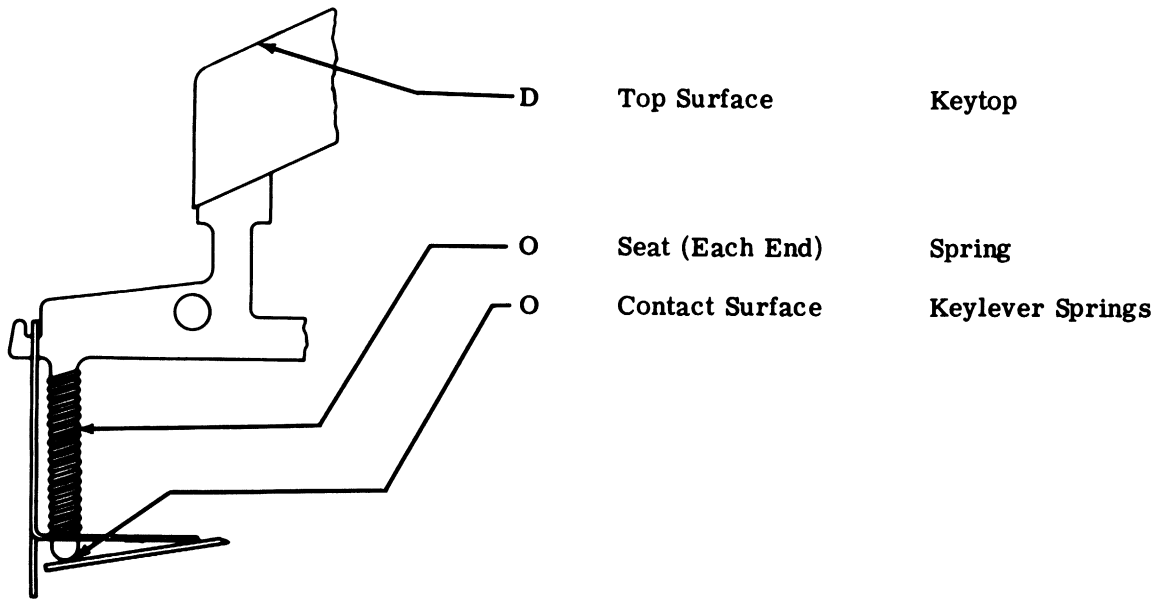

**(Right Side View)**

**2.14 Numeric Keylevers**

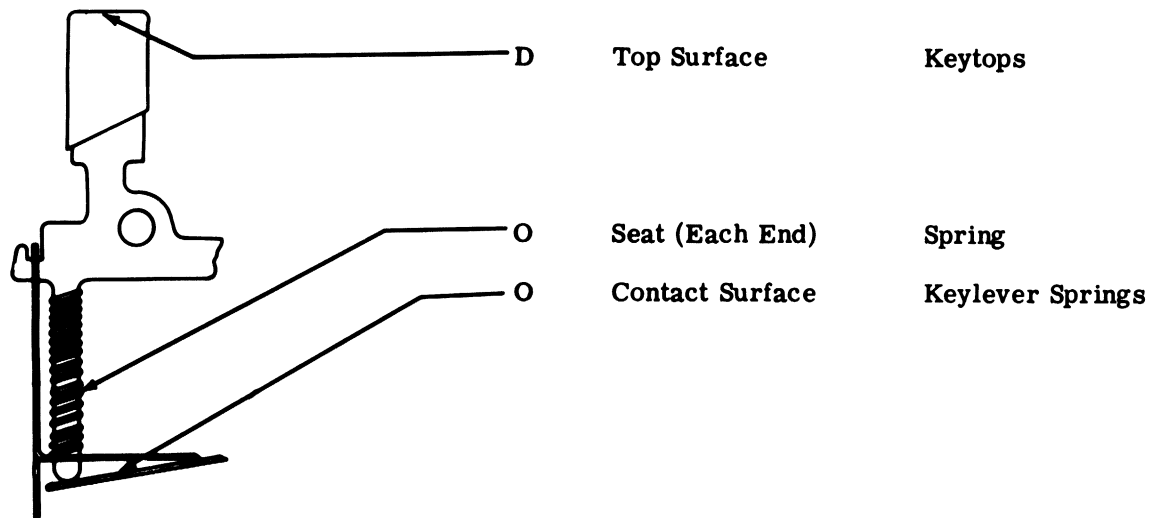

**(Right Side View)**



### 33 KEYBOARD

#### DISASSEMBLY AND REASSEMBLY

CONTENTS	PAGE
1. GENERAL . . . . .	1
2. DISASSEMBLY AND REASSEMBLY . .	1
KEYLEVER COVER . . . . .	1
KEYLEVER . . . . .	2
SPACEBAR MECHANISM . . . . .	3
CODEBAR . . . . .	4
KEYBOARD CONTACT MECHANISM . . . . .	4
AUXILIARY CONTACT MECHANISM . . . . .	4
T-LEVER SHAFT . . . . .	4

#### 1. GENERAL

1.01 This section is reissued to incorporate all recent engineering changes and to present disassembly and reassembly information exclusively for 33 keyboards. Since this is a general revision, marginal arrows, used to indicate changes, have been omitted.

1.02 References to left, right, front, rear, etc, consider the keyboard to be viewed from a position where the spacebar faces up and the contact mechanism is located to the viewer's right.

1.03 Disassembly, as outlined in this section, covers the procedure for removing the principle subassemblies which make up the unit. If further disassembly is required, refer to the appropriate illustrated parts section which shows detailed arrangements of parts. Where it will help in determining their location, the numbers of the parts are given in the instructions.

**CAUTION:** BEFORE BEGINNING DISASSEMBLY, REMOVE CONNECTORS FROM EXTERNAL RECEPTACLES (POWER SOURCE, DATA SET, ETC).

1.04 When self-tapping screws are used to mount mechanisms onto castings, do not remove the self-tapping screws. Merely loosen them enough to remove the mechanisms unless specifically instructed otherwise.

1.05 Retaining rings are made of spring steel and have a tendency to release suddenly. To avoid loss of these rings when removing them, proceed as follows:

- (a) Hold retaining ring to prevent its rotating.
- (b) Place blade of screwdriver in one of ring's slots and rotate screwdriver to increase diameter.
- (c) Ring will come off easily in fingers without flying.

1.06 All tools used to remove the mechanisms referred to in this section can be found in the 570-005-800TC standard tool section.

1.07 All damaged, worn, or distorted parts should be replaced if encountered in the disassembly and reassembly procedures.

#### 2. DISASSEMBLY AND REASSEMBLY

Note: For information concerning the proper procedure to remove the keyboard assemblies from the set, refer to appropriate disassembly and reassembly set section.

#### KEYBOARD COVER

2.01 To remove the keyboard cover (Figure 2), proceed as follows.

- (a) Remove TP119652 retaining ring from the left side of the keyboard cover, and rotate the left side bracket away.
- (b) Hold the right side bracket firmly in place against the two TP180031 compression springs of keyboard contact mechanism, and remove the TP119652 retaining ring from the right side of the keyboard cover.

- (c) Continue to hold the right side bracket firmly in place, and disengage the keyboard cover from the right side bracket by moving it up and to the left. Lift the keyboard cover off the keys.

Note: With the keyboard cover removed, the right side bracket may be pushed unexpectedly from its assembled position, due to the spring load of two compression springs. If this happens, certain parts may prematurely fall off. To prevent this, always keep the right side bracket firmly against the two compression springs of the keyboard contact mechanism, i e, either hold the right side bracket in place by hand or place it firmly against a fixed vertical surface.

- (d) To replace the keyboard cover, reverse the procedure used to remove it.

#### KEYLEVER

- 2.02 To remove any keylever (Figure 1), proceed as follows.

- (a) Depress the front end of the TP182240 (early design) or TP185766 (late design) universal lever.
- (b) Depress keylever and disengage it from front or rear guide slot.
- (c) Lift keylever out of keyboard frame.
- (d) To replace any keylever, reverse procedure used to remove it.

Note: Certain levers have compression springs on their lower stems. Make sure that the springs are properly replaced during reassembly.

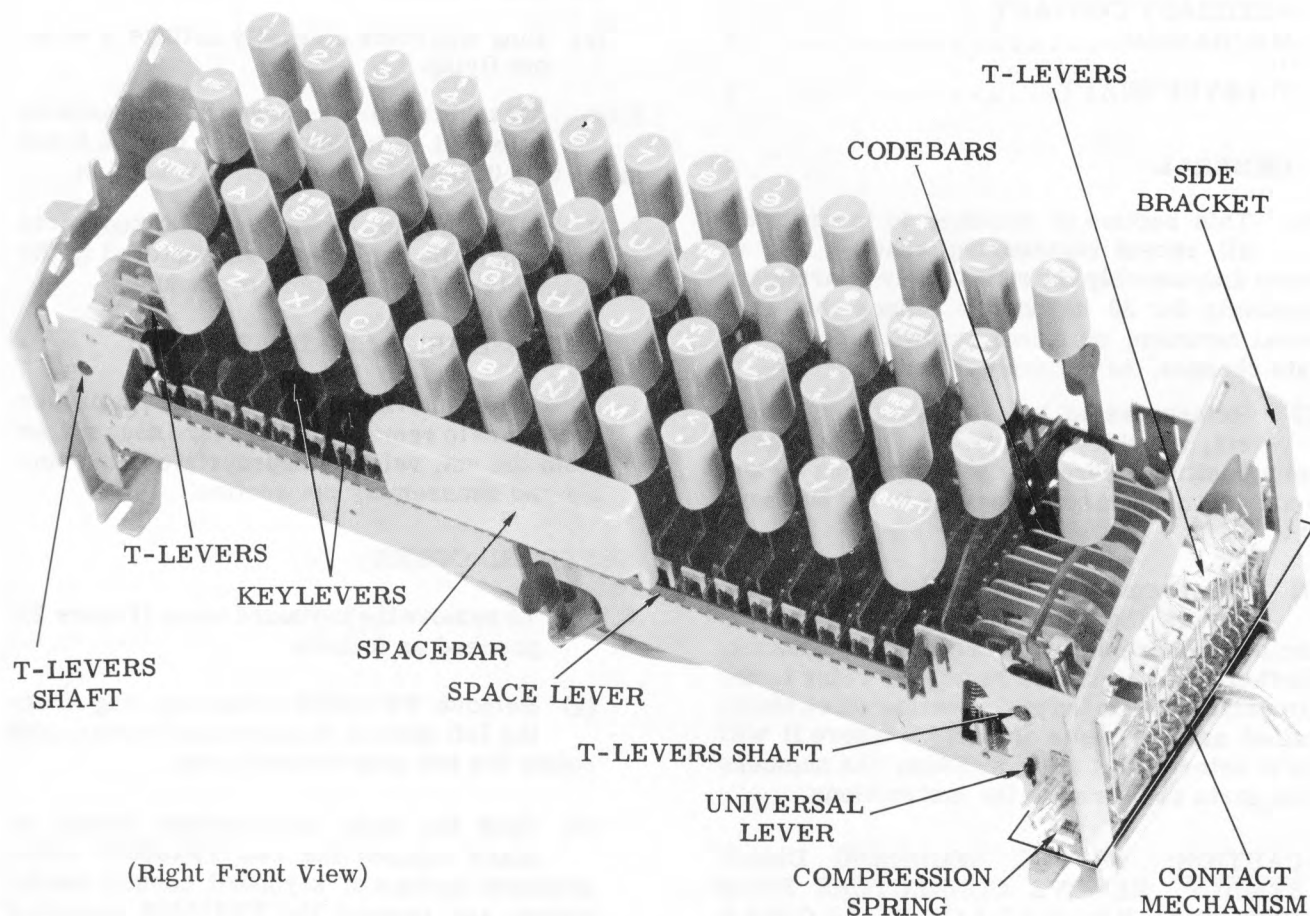

Figure 1 - Keyboard (Cover Removed)

SPACEBAR MECHANISM

2.03 To remove spacebar mechanism (Figure 1), proceed as follows.

- (a) Remove the TP180057 spacebar with the attached TP180054 keylever.
- (b) Bow the TP180056 space lever and disengage it from the two TP180055 space keylevers.

- (c) Disengage space keylevers from guide slots and remove them from frame.

Note: Careful attention should be given to the position of compression springs on keylever's lower stems so that they can be properly replaced during reassembly.

- (d) To replace spacebar, reverse procedure used to remove it.

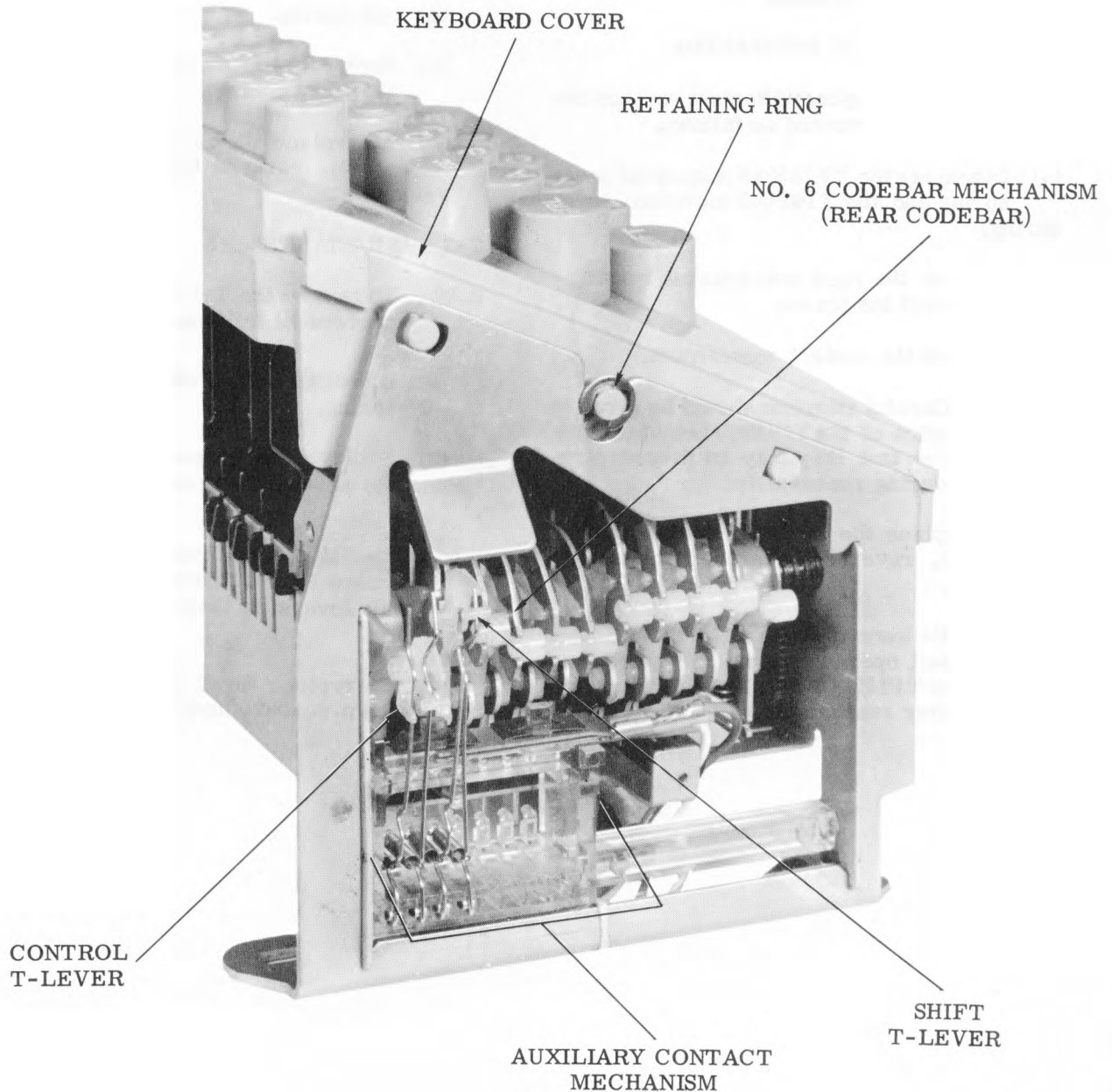

Figure 2 - Auxiliary Contact Mechanism

## SECTION 574-121-702TC

### CODEBAR

2.04 To remove any codebar (Figure 1), proceed as follows.

- (a) Remove all keylevers from typing unit.
- (b) Disengage codebars from left and right T-levers and remove them from keyboard frame.
- (c) To replace codebars, reverse procedure used to remove them.

### KEYBOARD CONTACT MECHANISM

2.05 To remove keyboard contact mechanism (Figure 1), proceed as follows.

- (a) Disengage the TP185798 nonrepeat lever spring and the TP82442 universal lever spring.
- (b) Remove the right side bracket by snapping it off the frame.
- (c) Remove the contact mechanism.

Note: Careful attention should be given to the position of the TP180031 compression springs so that they may be properly replaced during reassembly.

- (d) To replace the keyboard contact mechanism, reverse the procedure used to remove it.

Note: Be sure that the TP180046 contact reset bail operating arm is located beneath the TP182240 or TP185766 universal lever after reassembly.

### AUXILIARY CONTACT MECHANISM

2.06 To remove auxiliary contact mechanism (Figure 2), proceed as follows.

Note: These instructions apply only to parity keyboards.

- (a) Remove left side bracket by snapping it off frame.
- (b) Disengage the TP42661 (early design) or the TP186339 (late design) shift codebar link spring.
- (c) Spread keyboard frame and remove the auxiliary contact.
- (d) To replace the auxiliary contact mechanism, reverse the procedure used to remove it.

### T-LEVER SHAFTS

2.07 To remove the T-lever shafts (Figure 1), proceed as follows.

- (a) Disengage the TP84575 universal link spring.
- (b) Remove corresponding side bracket; spread the frame and lift out.

Note: If it is desired to remove T-levers, remove the TP119653 retaining rings and slide levers off their shafts.

- (c) To replace the T-lever shafts, reverse the procedure used to remove it.



33 TYPING UNIT

GENERAL DESCRIPTION AND PRINCIPLES OF OPERATION

CONTENTS	PAGE
1. GENERAL . . . . .	1
2. DESCRIPTION . . . . .	1
TECHNICAL DATA . . . . .	1
3. TELETYPEWRITER SIGNALING CODE . . . . .	3
4. PRINCIPLES OF OPERATION . . . . .	3
OUTLINE OF OPERATION . . . . .	3
DETAILED OPERATION . . . . .	8
A. Motor . . . . .	8
B. Main Shaft . . . . .	9
C. Clutches . . . . .	9
D. Signal Reception . . . . .	10
E. Distributor Mechanism . . . . .	10
F. Selector Mechanism . . . . .	12
G. Range Finder . . . . .	16
H. Codebar Mechanism . . . . .	16
I. Function Mechanism . . . . .	18
J. Printing . . . . .	20
K. Printing Suppressed . . . . .	26
L. Ribbon Mechanism . . . . .	28
M. Spacing Mechanism . . . . .	30
N. Space Suppression Mechanism . . . . .	31
O. Carriage Return Mechanism . . . . .	33
P. Paper or Form Feeding . . . . .	33
Q. Sprocket Feed Typing Units . . . . .	34
R. End of Line Bell . . . . .	38
S. Answer-Back Mechanism . . . . .	39

1. GENERAL

1.01 This section is reissued to provide information for the 33 typing unit only. Information on the 32 typing unit presented in Issue 1 has been omitted and is covered in Section 574-172-100TC. A general updating of

the 33 typing unit description and principles of operation is being presented, so that marginal arrows ordinarily used to indicate changes have been omitted.

1.02 References to left, right, front, or rear consider the typing unit as viewed by the operator.

1.03 In the illustrations fixed pivots are solid black, and floating pivots — those mounted on parts that move, are crosshatched.

1.04 The 33 typing unit is an electromechanical receiving device which prints graphics on a paper copy according to a code, and performs nonprinting functions.

2. DESCRIPTION

TECHNICAL DATA

2.01 Speed . . . . . 100 words per minute

2.02 Dimensions and Weight (Approximate)

Width . . . . . 13 inches  
 Depth . . . . . 14 inches  
 Height . . . . . 8 inches  
 Weight . . . . . 40 pounds

2.03 Signal Code Characteristics

8-Level  
 11-Unit Transmission Pattern

2.04 Electrical

Power requirements . . . . 115 volts ac  $\pm 10\%$   
 60 Hz  $\pm 0.45$  Hz, single phase  
 Signal line current . . 0.020 or 0.060 ampere  
 Nominal input to selector . . . 0.500 ampere  
 at 20 volts dc

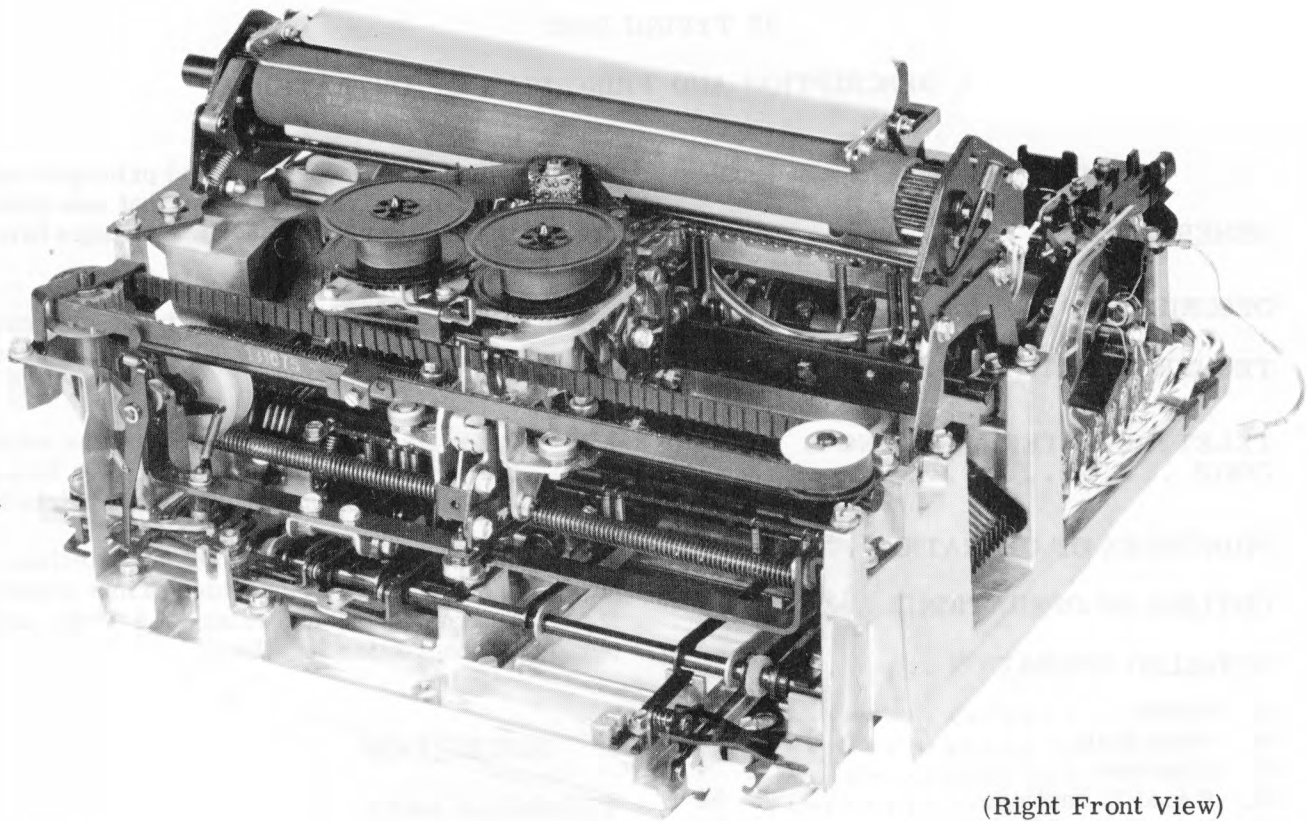

(Right Front View)

Figure 1 - 33 Typing Unit

Operating margins — all signal contacts and distributor:

- Long telegraph loops . . . 0.015 to 0.070 ampere at 48 to 240 volts dc inductive
- Short telegraph loops . . . . . 0.58 to 0.72 ampere at 16 to 22 volts dc resistive

2.05 Printing and Paper or Form Handling  
Feed

Friction or Sprocket: Six lines per inch, adjustable for single or double line feed

Paper or Form

- Friction Feed: 8-1/2 inches wide, max 5-inch diameter roll.
- Sprocket Feed: 8-1/2 inches wide; 7-, 8-1/2-, 9-, 10-, 11-, and 12-inch form lengths or multiples of 1/3 or 1/2 thereof.

Characters and Line

- Friction Feed: 10 character per inch, max 74 character line
- Sprocket Feed: 10 characters per inch, max 72 characters line

Legible Copies

- Friction Feed: Original and one copy
- Sprocket Feed: Original and two copies

2.06 Motor (TP181870) for Automatic Send-Receive Sets

- Type . . . . . Synchronous, capacitor start
- Input . . 115 volts ac  $\pm 10\%$ , 60 Hz  $\pm 0.45$  Hz, single phase
- Input current . . . . . 2 amperes
- Output . . . . . 33 millihorsepower
- Speed . . . . . 3600 rpm
- Temperature rating . . . . . 50°C continuous
- Power factor . . . . . 0.40



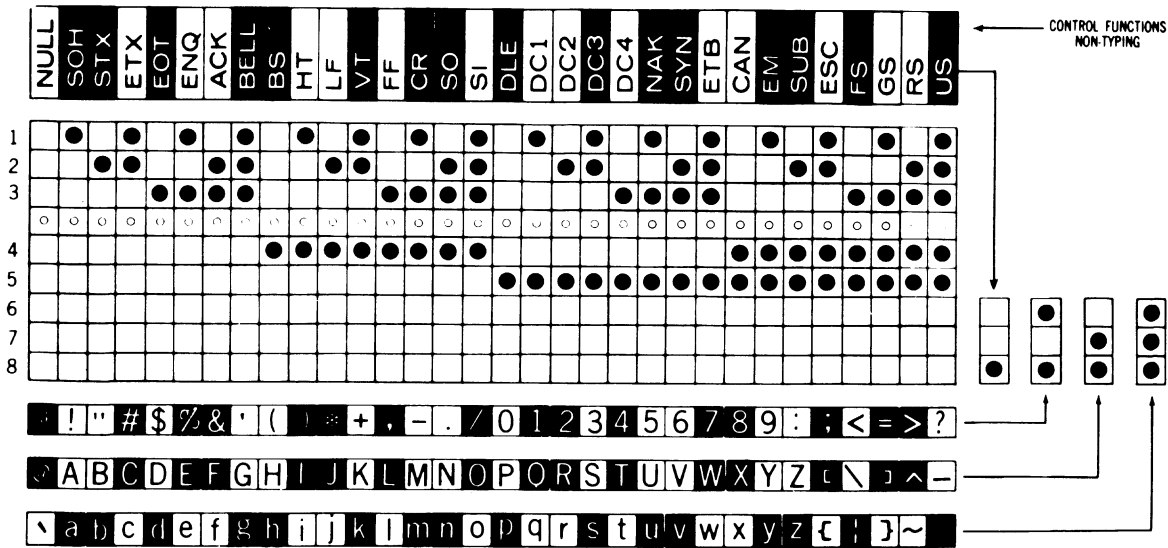

USA STANDARD CODE FOR INFORMATION INTERCHANGE (ASCII) X3.4-1967

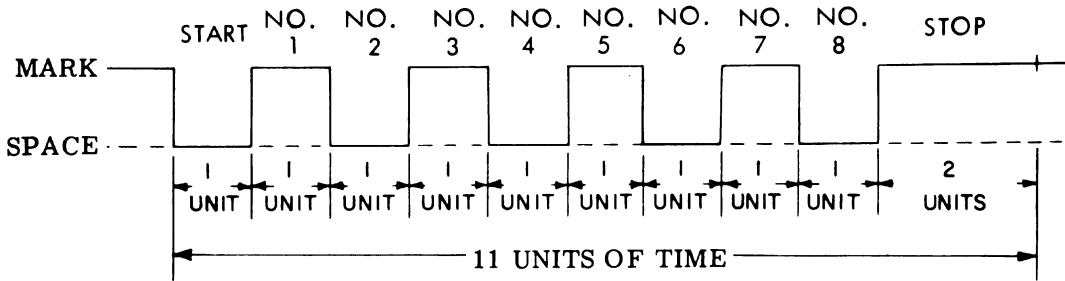

CURRENT WAVE FORM FOR LETTER "U" (WITH "EVEN PARITY")

Figure 2 - Teletypewriter Code (8-Level)

the "space" code combination is received. The function mechanism suppresses spacing on the receipt of all functions except "space." At the receipt of "carriage return" code combination, the function mechanism causes the spacing mechanism to return the carriage to the left margin, so that a new printing line can be started.

**Paper Feed Mechanism — Friction Feed Typing Units**

4.05 The paper feed mechanism positions the paper vertically so that the characters are properly located in lines on the paper. At the receipt of the "line feed" code combination,

the function mechanism causes the line feed mechanism to raise the paper to the next printing line.

**Form-Feed Mechanism — Sprocket Feed Typing Units**

4.06 The form-out mechanism positions the form vertically so that the characters are properly located in lines on the form. At the receipt of the "line feed" or "form out" code combination, the main shaft, through a line feed clutch, causes the platen to raise the form to either the next printing line or one form length, depending upon which function ("line feed" or "form out") is used.

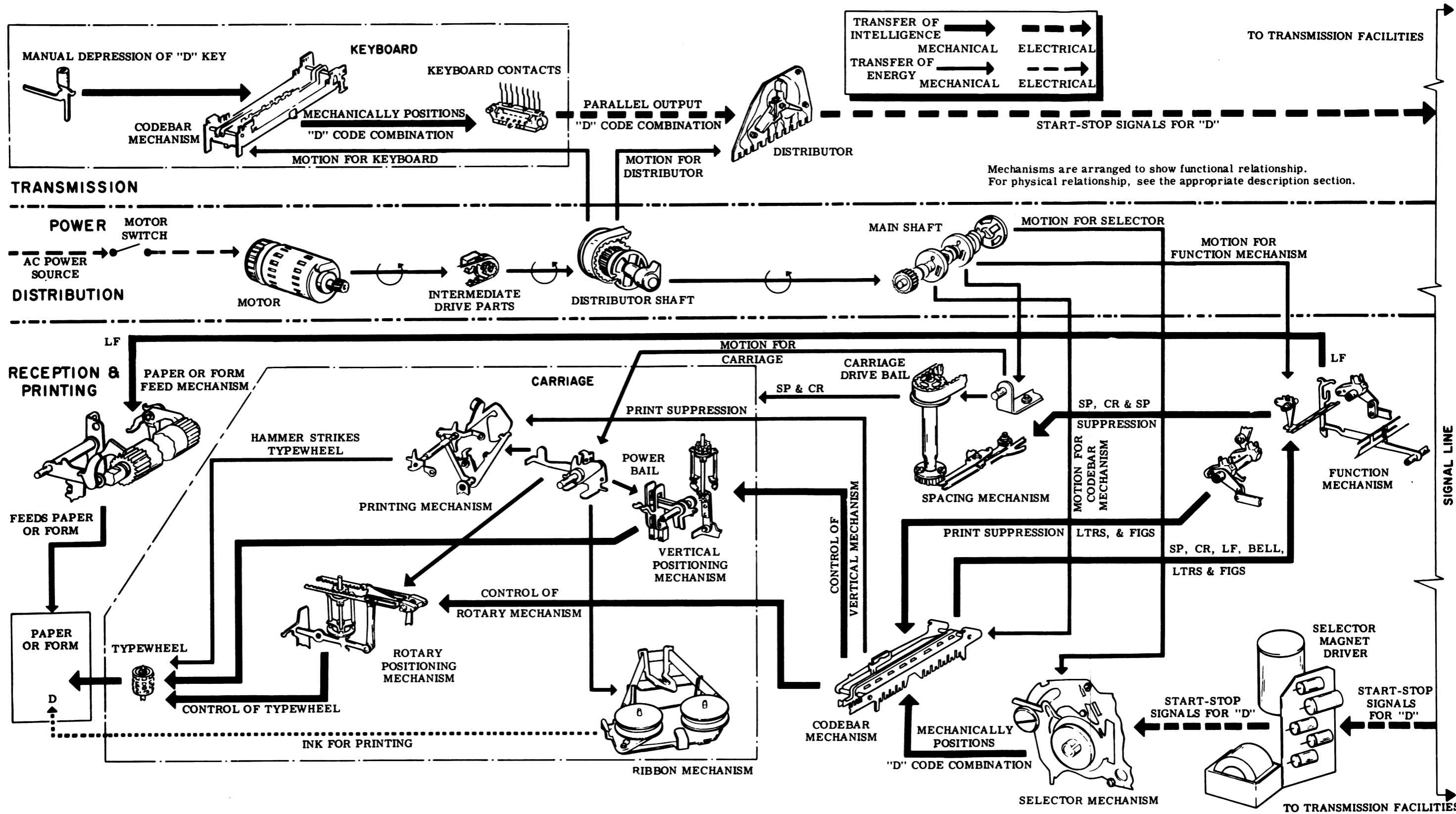

Figure 3 - Schematic Diagram — Typing Unit Operation

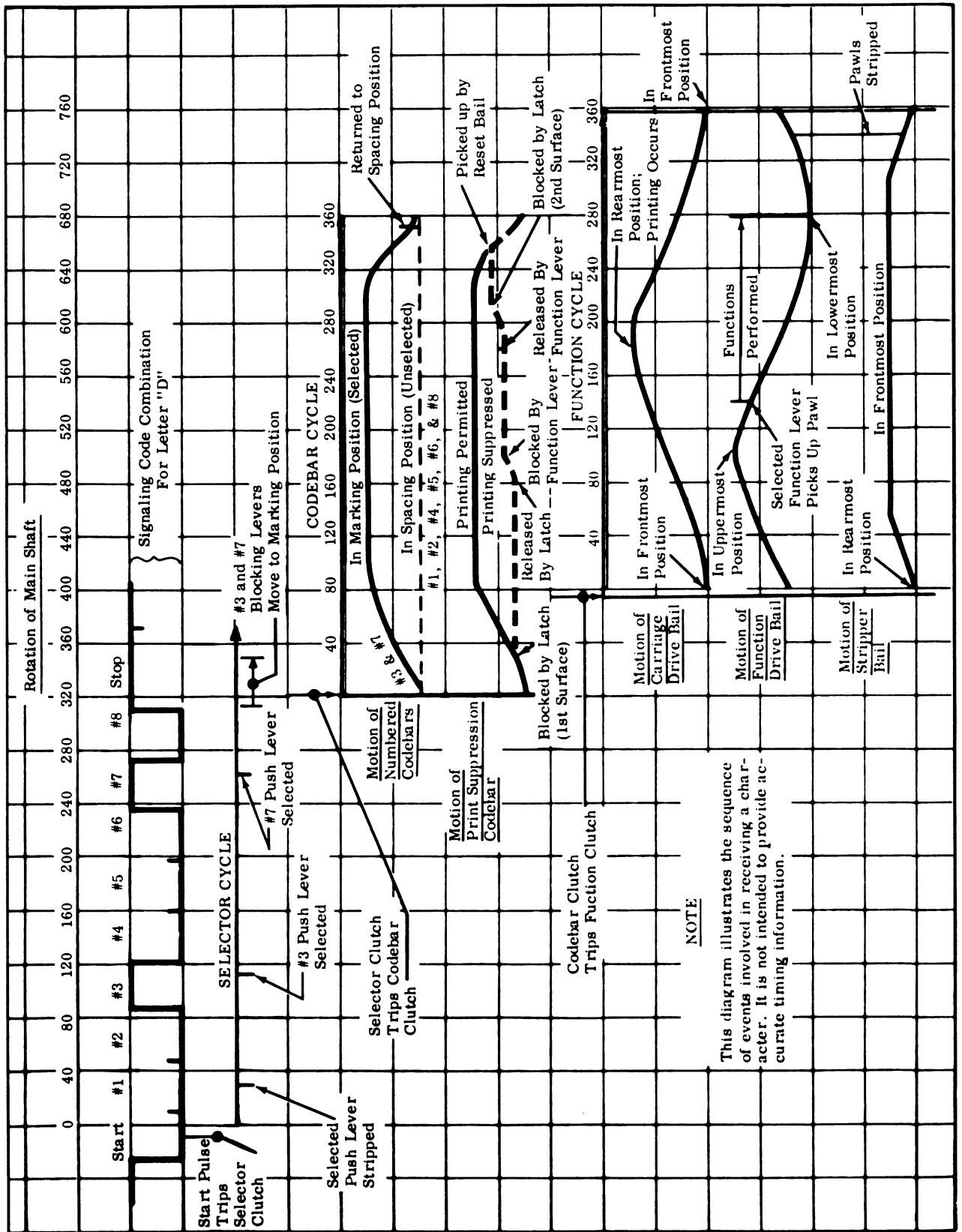

Figure 4 - Sequence Diagram — 33 Typing Unit Operation

DETAILED OPERATION

A. Motor

4.07 The motor used on the 33 typing unit has a run winding and a start winding connected in parallel. (See the appropriate schematic wiring diagram.) The start winding is in series with an electrolytic capacitor and the contacts of a current-sensitive start relay. The run winding is connected to a run capacitor. When the motor circuit is closed, the initial surge of current energizes the relay coil, closing the relay contacts. The magnetic flux produced by the operating and start windings starts the motor turning. As the rotor accelerates,

the current, through the windings, capacitor, and relay decreases. When it drops to a pre-determined level, the relay coil opens the contacts and removes the start coil from the circuit. Using the operating coil alone, the motor continues to accelerate until it reaches synchronous speed.

4.08 The rotary motion produced by the motor is transferred through a motor pinion, an intermediate gear pulley, and a motor belt to a distributor gear pulley. The latter drives a main shaft gear and also a distributor clutch, which provides motion for the keyboard and distributor mechanism (Figure 5).

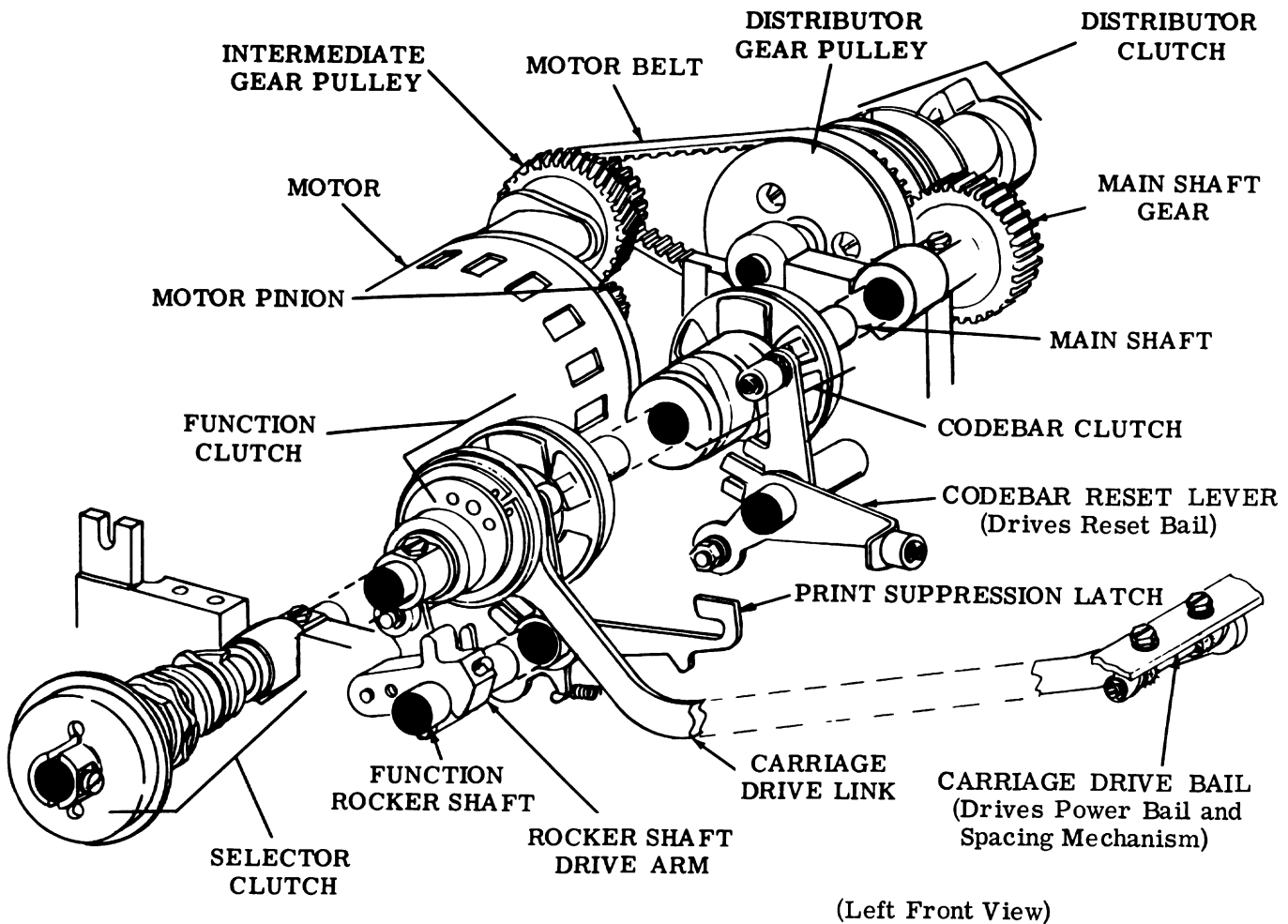

Figure 5 - Motor and Drive Mechanism

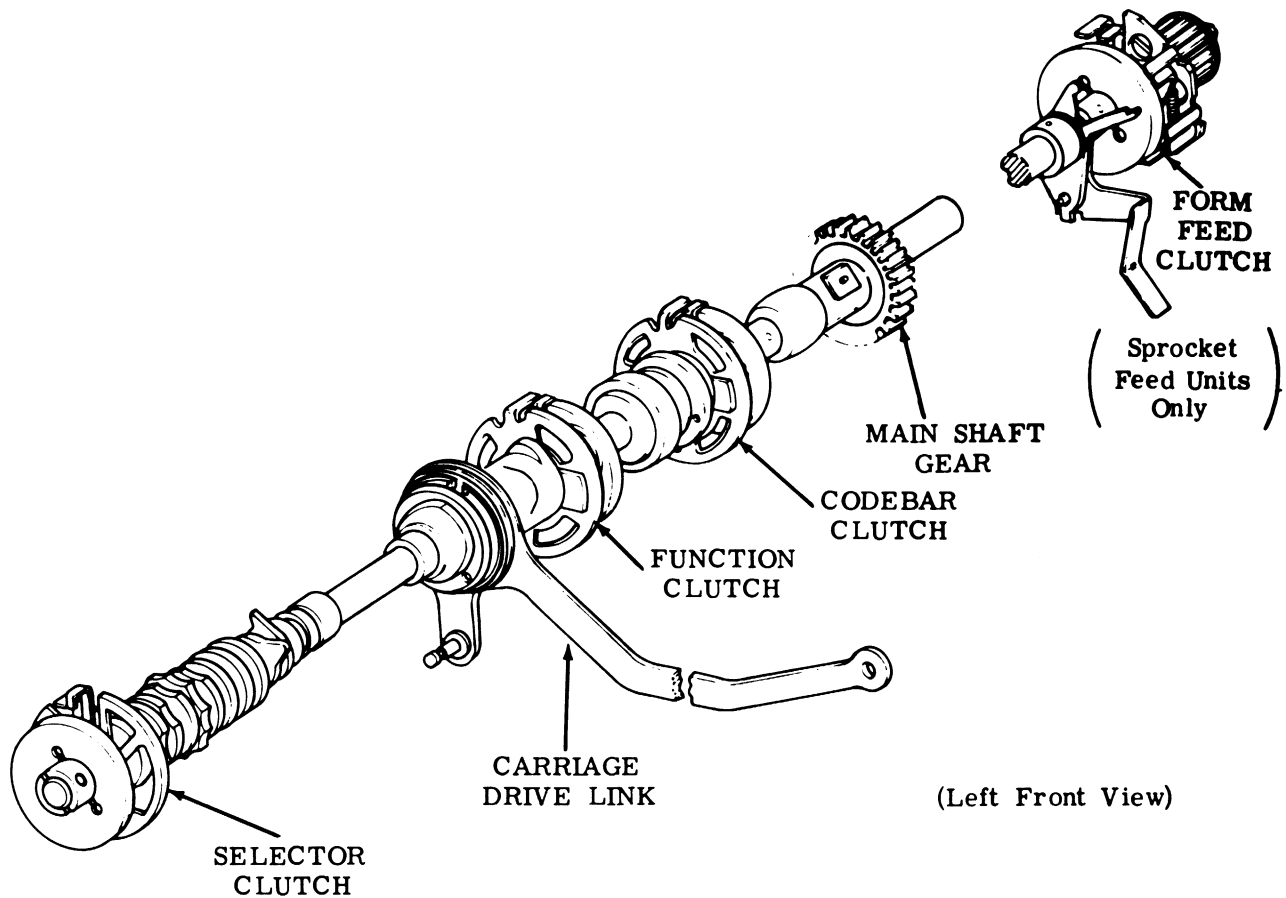

Figure 6 - Main Shaft

## B. Main Shaft

4.09 The main shaft illustrated in Figure 6 receives motion from the motor, and by means of clutches distributes it to drive all the mechanisms in the typing unit except the distributor mechanism. The distributor mechanism is driven by the motor directly as explained in 4.08. In friction feed typing units the main shaft drives three clutches: the selector clutch, the function clutch, and the codebar clutch. In sprocket feed typing units the main shaft drives an additional clutch — the form feed clutch.

## C. Clutches

4.10 The clutches used on the 33 typing unit are all metal internal expansion clutches. A clutch is illustrated in Figure 7. This type of clutch functions like brakes. When the clutch is tripped (engaged) two shoes expand against a notched drum. The force of the expanded shoes against the clutch drum is enough to engage the drum. As the drum rotates, the whole clutch and any mechanism attached to it will rotate.

4.11 The clutch drum is attached to and rotates with a shaft. In the stop (or disengaged) position, a trip lever and a latch lever hold the shoe lever, two shoes, a cam disc, and a cam sleeve stationary. When the trip lever moves away from the shoe lever, the shoe lever, under spring tension, moves away from the stop lug on the cam disc. By means of two lugs, the shoe lever expands the shoes until they contact the notched surface of the drum. The drum causes the shoes to rotate. By means of a lug on the cam disc the shoes rotate the disc and the sleeve attached to it. The clutch is now engaged, and the cam sleeve rotates in unison with the shaft.

4.12 When the trip lever moves to its stop position, it is struck by the shoe lever. The cam disc continues to rotate until the latch lever seats in its notch, and the shoe lever and stop lug are pressed together by the trip lever and latch lever. A spring holds the shoes together, away from the drum. The clutch is now disengaged.



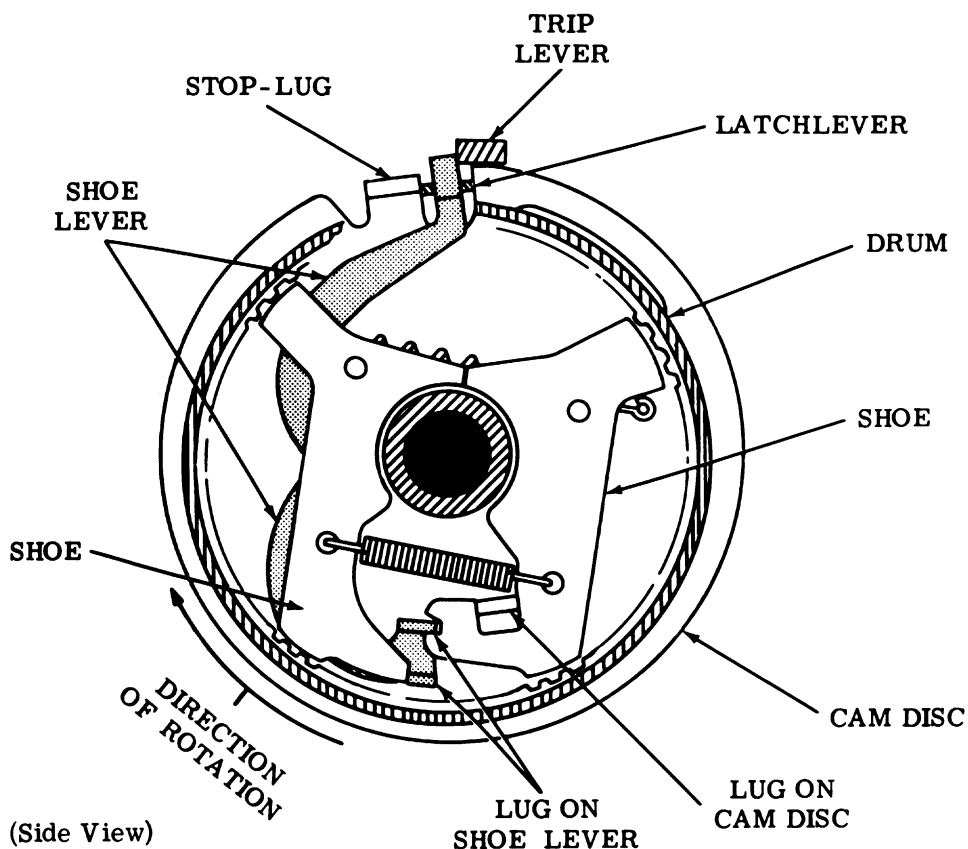

Figure 7 - Internal Expansion Clutch

#### D. Signal Reception

4.13 The signal received by the typing unit may originate either remotely or locally. Locally the signal may originate either in the keyboard or the tape reader. In either case, the incoming signal is received as a parallel output to the distributor. The distributor changes the parallel signal into a serial start-stop output to the selector magnet driver for current rectification. The signal goes from the selector magnet driver to the selector. The following paragraphs will consider the signal as originating in the keyboard. Refer to Section 574-121-100TC for the description of keyboard operation.

#### E. Distributor Mechanism

4.14 The distributor mechanism is illustrated in Figures 8 and 9. When a keytop is depressed, the corresponding code combination is set up in the keyboard contacts. Simultaneously the universal lever moves up. An H-plate

connects the universal lever of the keyboard to the distributor clutch trip linkage in the typing unit. As the universal lever moves up, the H-plate pivots the distributor trip linkage. The distributor trip linkage is connected to the clutch trip lever. As the linkage moves rearward the trip lever is moved away from the shoe lever and the distributor clutch engages.

4.15 The clutch disc is attached to the distributor shaft. A brush holder mounted at the end of the distributor shaft rotates two carbon brushes over the segments of the distributor disc. A spring fastened to the brush holder serves two purposes: it holds the carbon brushes firmly against the segments, and serves to close the current loop between the outer and inner rings of the distributor disc.

4.16 The distributor disc has two rings. The inner ring is solid. The outer ring is broken into ten segments corresponding to the start, stop, and the eight intelligence pulses.

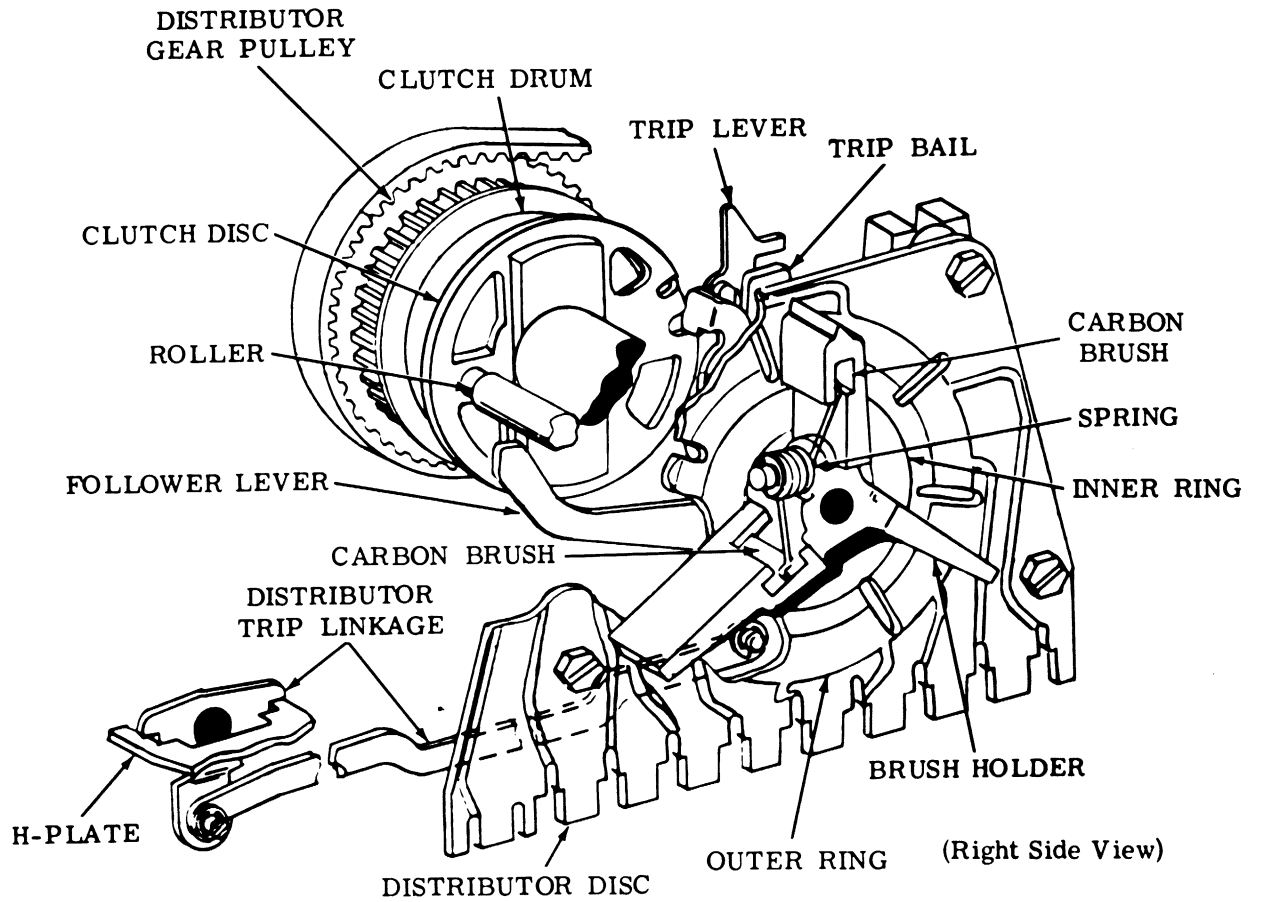

Figure 8 - Distributor Mechanism

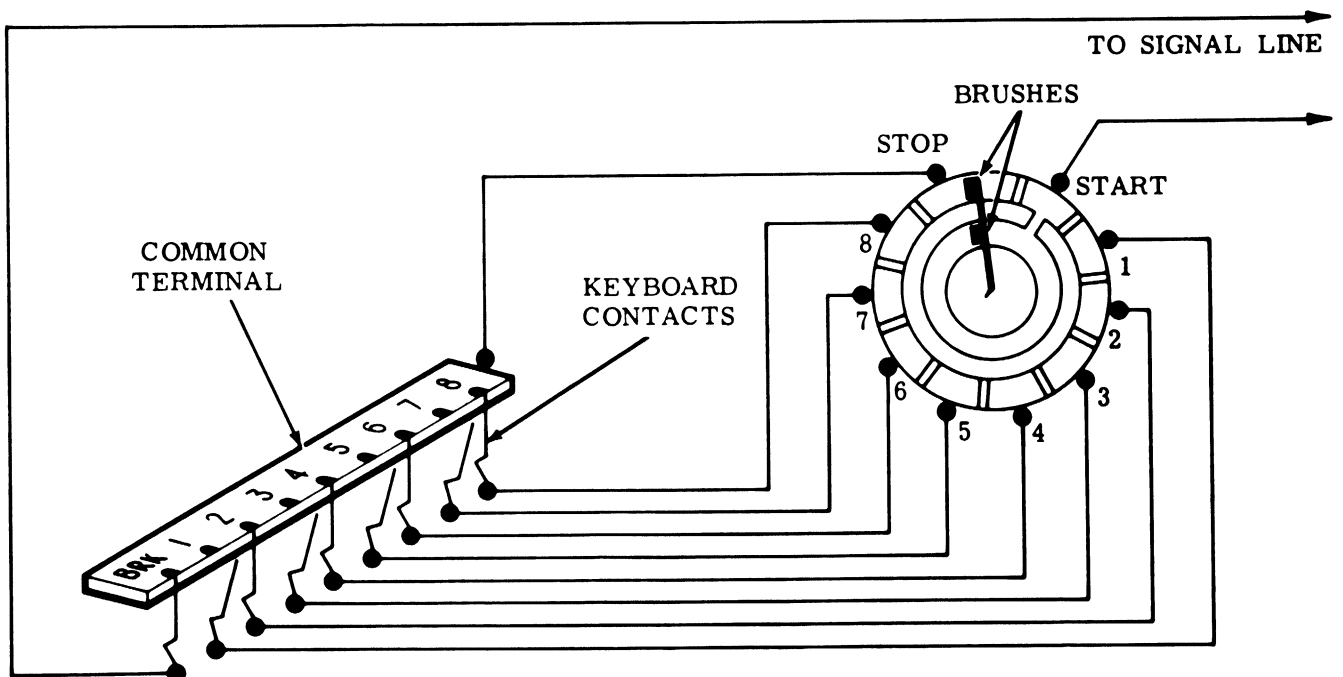

Figure 9 - Signal Wiring for 33 Typing Unit Distributor

## SECTION 574-122-100TC

(a) In the stop position, the outer brush rests on the stop segment, and the current flows in the signal circuit which is closed. (The signal path is from one side of the line through the start segment, the inner ring, the brushes, the stop segment, the common terminal, and the break contact to the other side of the line.) Thus a marking condition exists. Assume that the D key is depressed. The (--3---7-) code combination is set up in the keyboard contacts.

(b) The distributor clutch is tripped, and the brush holder begins its revolution. While the brush is on the start segment, the circuit is open, no current flows, and a spacing element is transmitted. While it is on the no. 1 segment, the circuit is again open. Likewise the circuit is open for the no. 2 pulse. On the no. 3 segment the circuit is closed, current flows and a marking element is transmitted. For the nos. 4, 5, and 6 segments the circuit is open, transmitting spacing elements. The circuit closes for the no. 7 element and opens for the no. 8. When the brush reaches the stop segment, the distributor clutch is disengaged, and the line again becomes marking.

### F. Selector Mechanism

4.17 The selector mechanism illustrated in Figures 10 and 13 receives the code combinations from the selector magnet driver and converts them to mechanical arrangements that control the codebar mechanism.

4.18 A magnet coil is wired by two leads to the output of the selector magnet driver. In the stop condition the output of the selector magnet driver is marking. This keeps the coil energized and the armature attracted to the magnet core. In this attracted position the armature blocks the start lever.

4.19 When a code combination is received the start pulse (spacing) de-energizes the coil, and the armature drops away from the magnet. No longer blocked, the spring biased start lever overtravels the armature, causing two things to happen:

- (a) The start cam follower associated with the start lever falls into the indent of the start cam.
- (b) As the start cam follower falls into the indent, the trip lever associated with it moves away from the clutch shoe lever, allowing the selector clutch to engage.

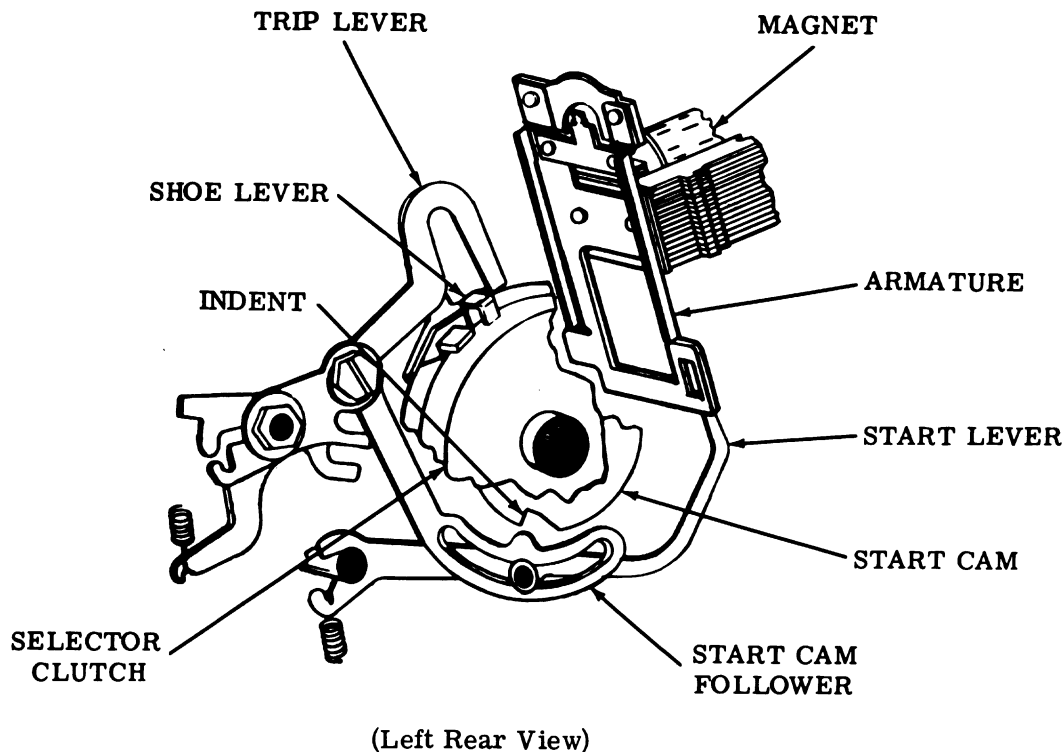

Figure 10 - Selector Trip Mechanism

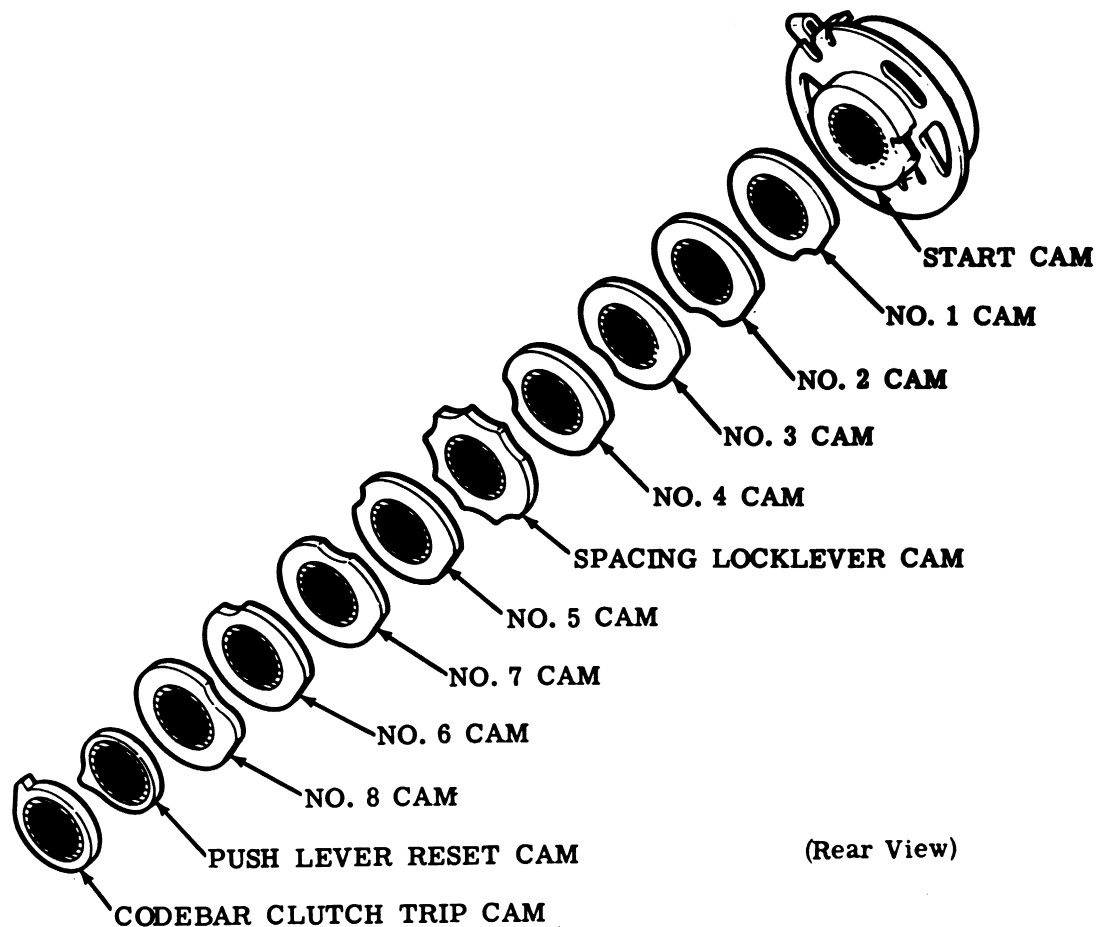

Figure 11 - Selector Cam Sleeve

4.20 Once engaged the selector clutch makes one complete revolution. The start cam follower remains in the indent of the start cam just enough to trip the clutch. It then comes out of the indent and rides the cam. This keeps the start lever away from the armature which will now be attracted if the incoming pulses are marking and unattracted if the pulses are spacing.

4.21 As the selector clutch rotates, the spacing locklever, the push lever reset bail, the codebar clutch trip follower arm, and eight selector levers ride individual cams under spring tension.

4.22 Early in the codebar cycle the high part of the push lever reset cam pivots the push lever reset bail. In its motion the bail

resets all the spring biased push levers selected in the previous cycle. Once reset the push levers can be positioned either marking or spacing as the intelligence pulses are received.

4.23 The selector cam sleeve illustrated in Figure 11 has twelve cam surfaces. The cam surfaces are positioned in a staggered fashion so that a sampling sequence can take place. As mentioned in 4.19 and 4.20, the start cam performs its function, and soon after the push lever reset cam is operated. Following these the spacing lock lever cam and the eight intelligence cams operate in sequence.

Note: The sampling sequence for the intelligence cams is as follows: no. 1, 2, 3, 4, 5, 6, 7, and 8. However, the physical arrangement of the cams is: 1, 2, 3, 4, 5, 7, 6, and 8 as viewed from left to right.

4.24 If the intelligence pulse is spacing it de-energizes the magnet coil and the armature is in the unattracted position. The spacing lock lever moves up, holding the armature in this position during the sampling interval. The selector lever is prevented from moving up into the indent of its cam by the armature, and the push lever remains in its unselected (spacing) position in front of the selector lever (Figure 12).

4.25 If the intelligence pulse is marking the armature is attracted, moving out of the way of the selector lever, blocking the spacing lock lever. The selector lever moves up into the indent of its cam, locking the armature in its marking position during the sampling interval. This permits the spring biased push lever to move rearward under the selector lever.

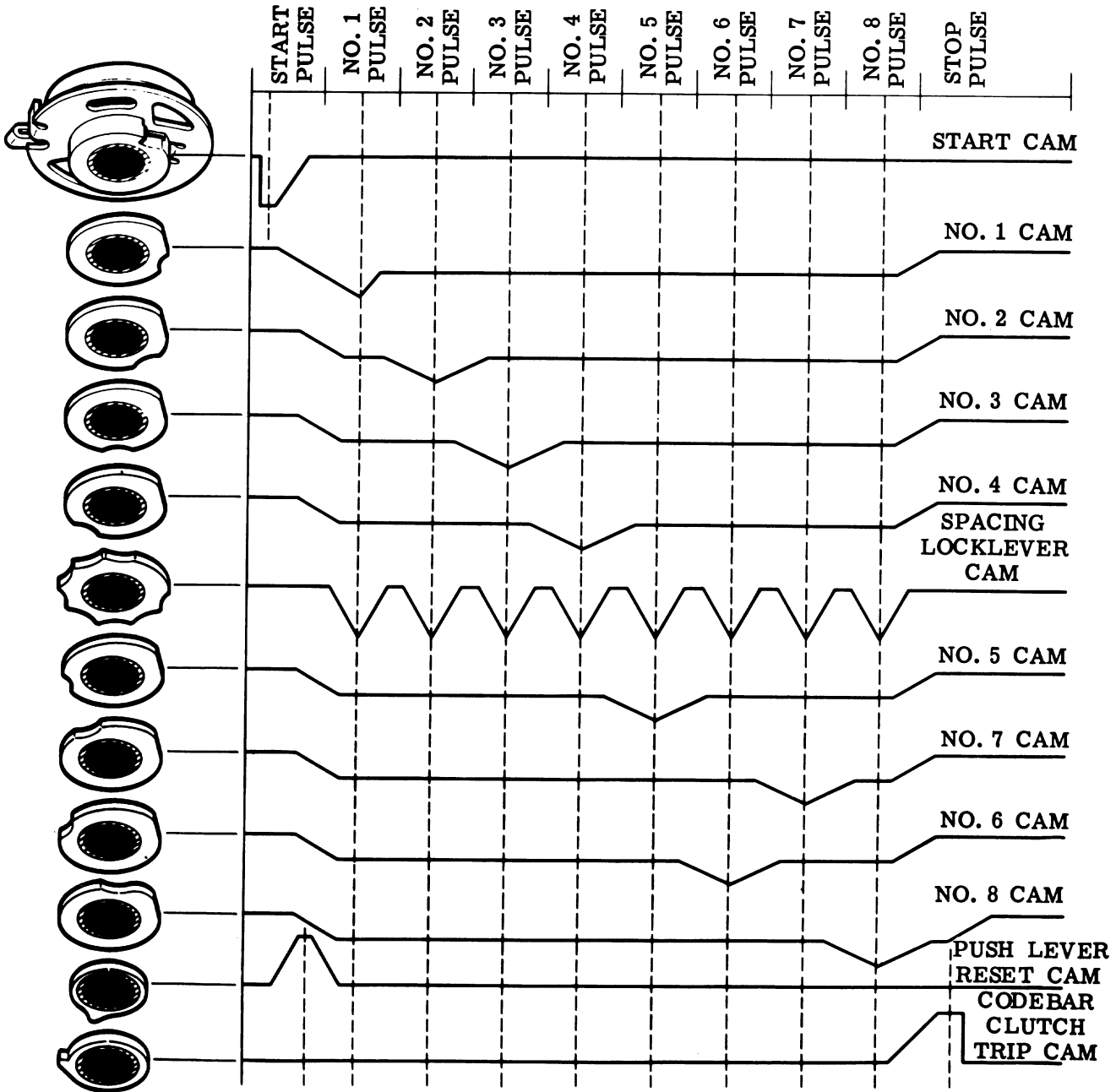

Note: This illustration is intended to show relationships of operations. It is not meant to be a timing chart.

Figure 12 - Sequence and Relationships of Selector Cams Operations

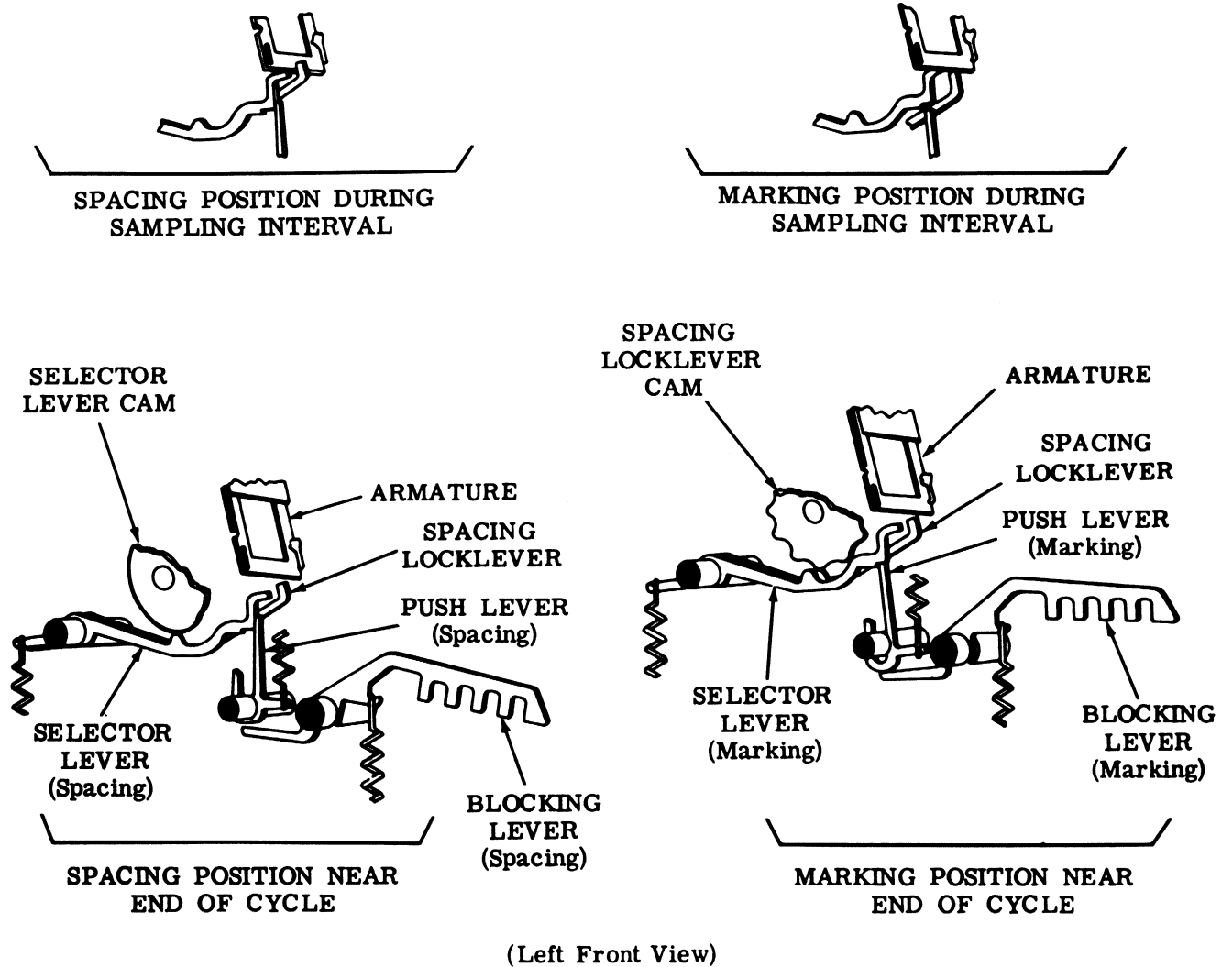

Figure 13 - Selector Mechanism

4.26 As the code combination is received, each intelligence pulse is sampled in turn, and the corresponding selector levers and push levers are positioned accordingly. The contours of the selector cams are such that near the end of the cycle they drive the selector levers and selected push levers towards the front of the typing unit to their marking position. In this position their slotted portions are up. The blocking levers associated with the unselected push levers remain in the spacing position in which their slotted portion is down (Figure 13).

4.27 Near the end of the cycle, the trip follower arm is moved rearward by its cam and trips the codebar clutch.

4.28 When the stop pulse (marking) is received at the end of the code combination, the armature moves to its marking position above the start lever, where it prevents the start cam follower from falling into the indent of its cam. In this position the follower holds the trip lever down so that, when the selector clutch completes its cycle, its shoe lever strikes the trip lever, and the clutch is disengaged.

4.29 As an example, assume that the letter D (--3---7-) code combination is received by the typing unit. The start pulse (spacing) trips the selector clutch, which begins its cycle. The stripper bail strips all previously selected push levers from the selector

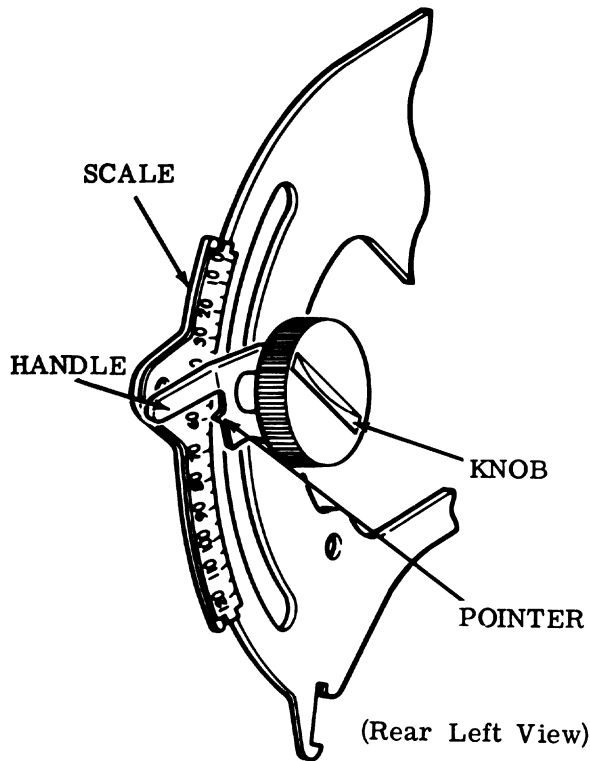

Figure 14 - Range Finder

levers. The intelligence pulses are samples in order, and the no. 3 and no. 7 push levers are selected. Near the end of the cycle the selector clutch cams the no. 3 and no. 7 push levers down, and they pivot the no. 3 and no. 7 blocking levers up to their marking position. The trip cam causes the trip follower arm to trip the codebar clutch. The stop pulse (marking) disengages the selector clutch, and the selector returns to its stop position.

#### G. Range Finder

4.30 For optimum operation of the typing unit, the selector must sample the code elements at the most favorable time. The range finder illustrated in Figure 14 provides a means of determining this time by establishing a range of operating margins.

4.31 When the range finder knob is loosened, a pointer may be moved along a range scale by a handle. This changes the angular position of the trip levers and latchlevers with respect to the main shaft, and thus changes the position where the selector clutch begins and

ends its cycle. The effect of this operation is to change the time in the cycle when the selector samples each code pulse.

4.32 Rotating the pointer counterclockwise from 60, the center of the scale, causes the selector to sample the trailing portion of the pulse. Rotating the pointer clockwise causes the selector to sample the leading edge. To establish the margins of the operating range, the pointer is moved first in one direction, then in the other, until errors in printing occur. The pointer is then set at the center of the range and the knob tightened.

#### H. Codebar Mechanism

4.33 As mentioned in 4.27, near the end of the selector cycle (towards the end of the eighth pulse) the codebar clutch trip cam pivots the codebar clutch trip follower arm. The arm, through a trip shaft, pivots the trip lever out of the way of the shoe lever. The codebar clutch engages and makes one revolution.

4.34 As the codebar clutch rotates the codebar reset lever follows its camming surface under the pressure of the codebar reset bail spring. The rotary motion of the cam is applied as an oscillating motion to the codebar reset lever. The codebar reset lever in turn applies its motion to the codebar reset bail which oscillates from right to left when viewed from the front of the unit.

4.35 There are ten codebars in the codebar mechanism illustrated in Figure 15. The function of the codebars is to sense the marking and spacing positions of the blocking levers. As the reset bail pivots, the codebars move up and to the left to sense the positions of the blocking levers. If a blocking lever is up (marking) a projection on the blocking lever comes in contact with a projection on the codebar, keeping it in a down position. The operation of individual codebars will be described in succeeding paragraphs in conjunction with other mechanisms. Function levers positioned under the codebars and stop slides riding the top of the codebars will be described later.

4.36 Early in the codebar cycle a trip cam pivots a follower arm which trips the function clutch. Near the end of the cycle the cam, through the reset lever, pivots the reset bail to the left. This allows the codebars to return to their stop (down and right) position.

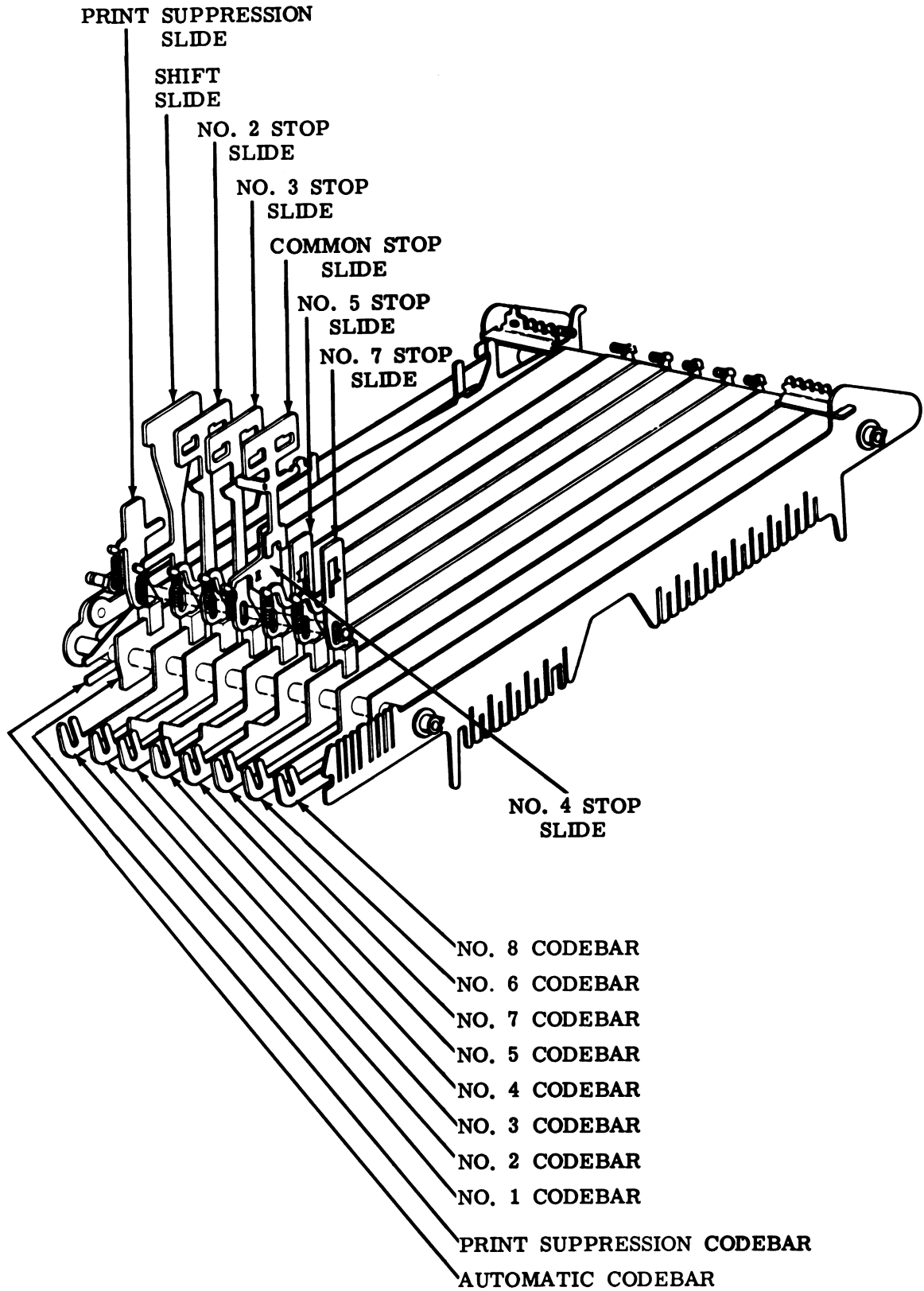

(Front Left View)

Figure 15 - Codebar Arrangement



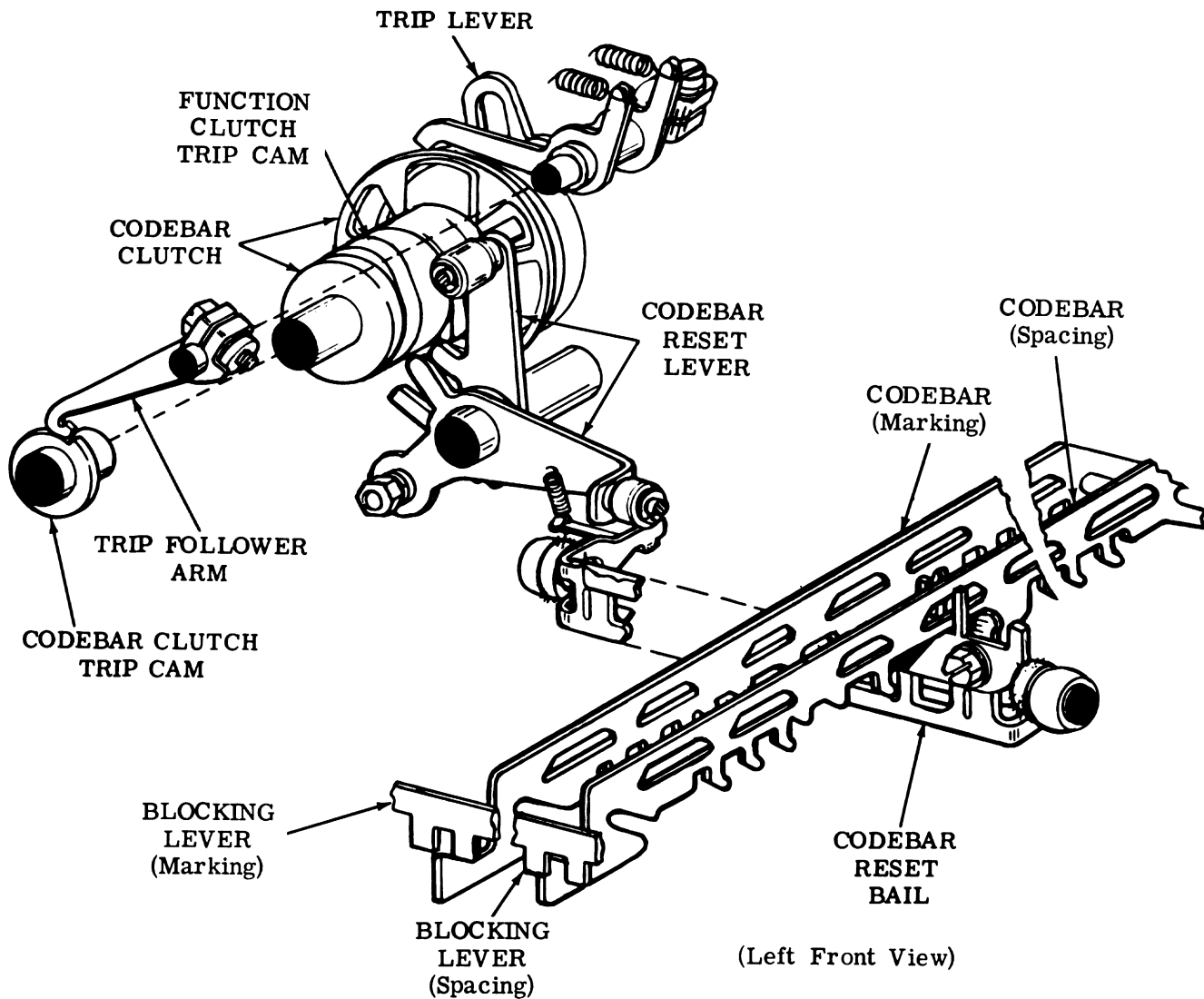

Figure 16 - Codebar Mechanism

### I. Function Mechanism

4.37 The function mechanism illustrated in Figure 17 enables the typing unit to perform functions at the receipt of the proper code combinations. Functions are operations supplementary to printing the message, such as carriage return and line feed.

4.38 Early in the codebar cycle a cam pivots the function trip follower arm, which moves the function trip lever out of engagement with its shoe lever. The function clutch engages and makes one complete revolution. The function drive cam, through a follower arm and drive arm, causes the function rocker shaft to rock. The function rocker shaft, through two

drive linkages, moves a function drive bail up during the first part of the cycle and down during the middle portion.

4.39 The underside of the codebars are coded by a series of notches and projections. Under the codebars are a number of function levers which pivot on the same shaft as the function drive bail, and are connected to the bail by springs. As the bail moves up, the springs pull the function levers up so they sense the codebars. If a lever encounters one or more projections, it is retained in its down position against the tension of its spring. If the slots line up such that an opening is provided for a function lever, the lever moves all the way up to its selected position.

4.40 In most cases, when a function lever moves up to a certain level, it is latched by an associated function pawl. Then, when the function drive bail pulls the lever and latched pawl down during the middle portion of the cycle, the pawl provides the motion to effect the function.

end of the cycle the cam permits the drive arm, under spring tension, to move the stripper bail rearward and strip any latched function pawls from their selected function levers.

4.41 Near the beginning of the function cycle, a cam pivots a drive arm which moves the function stripper bail frontward. Near the

4.42 The operation of the individual function levers and pawls is covered under the individual functions.

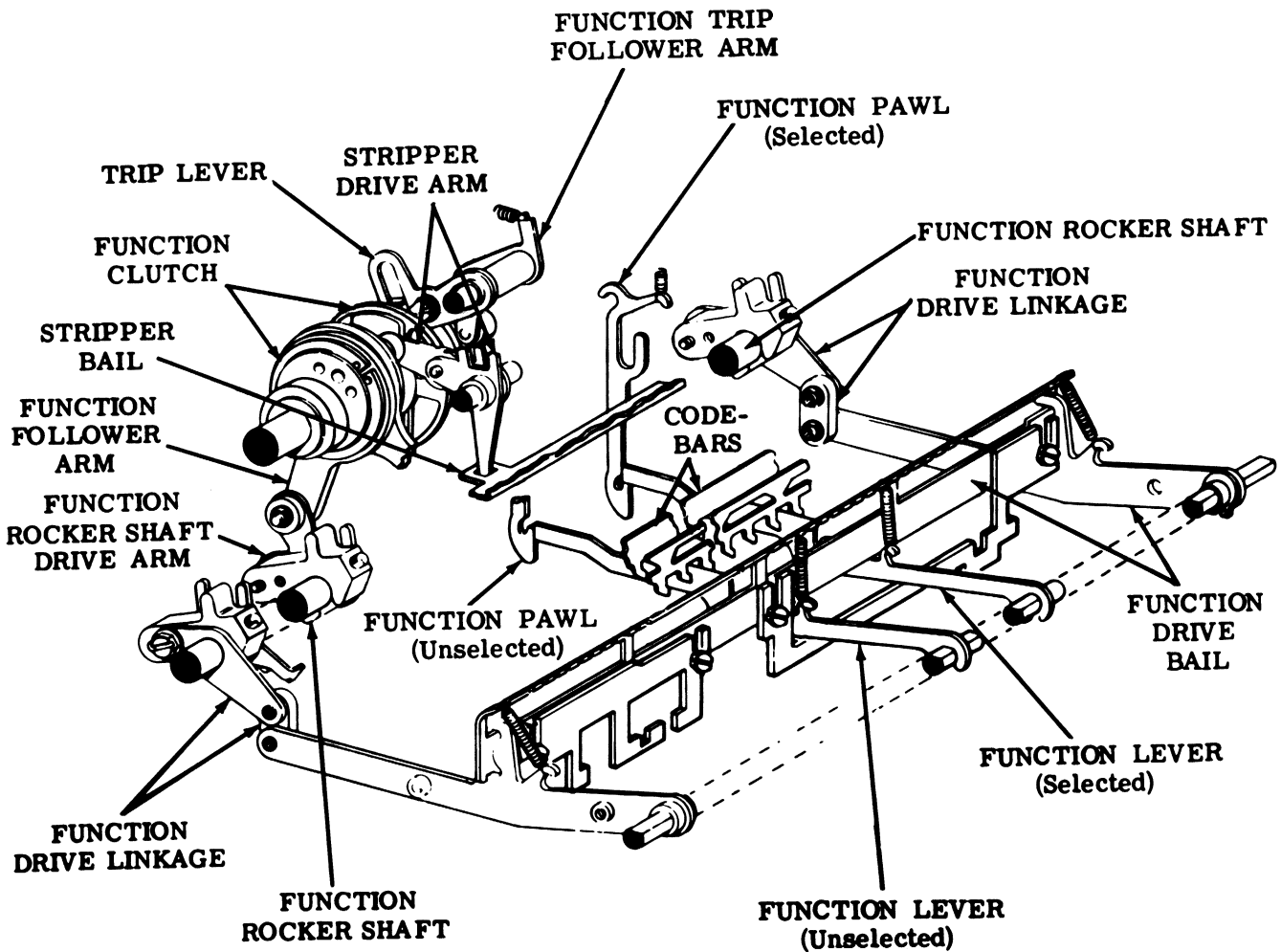

(Left Front View)

Figure 17 - Function Mechanism

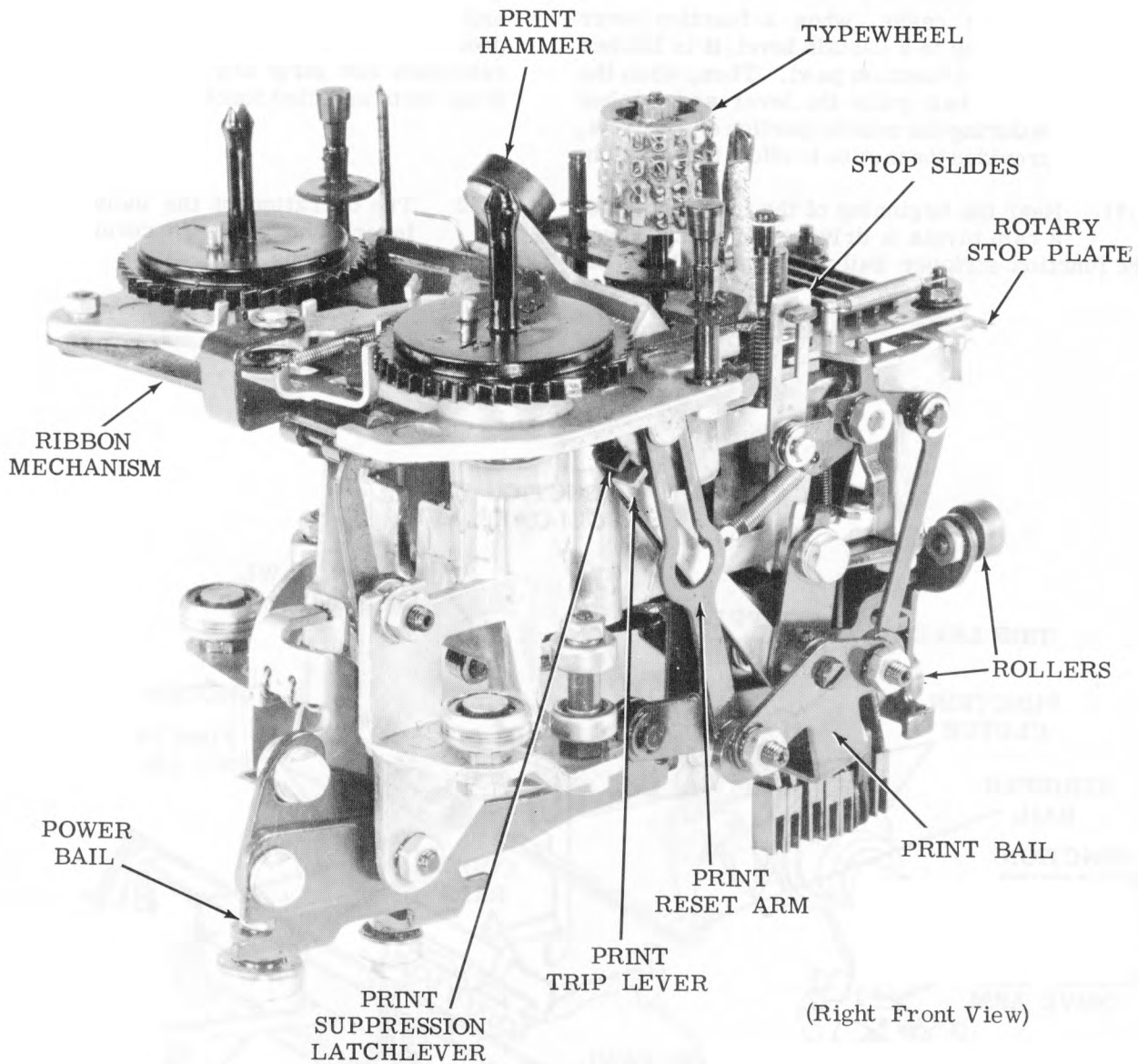

Figure 18 - Print Carriage

J. Printing

General

4.43 The printing of characters on paper is accomplished by the print carriage shown in Figure 18.

Typewheel

4.44 The characters used in printing are embossed on the cylindrical surface of a typewheel. A typewheel character arrangement

is shown in Figure 19, in which the cylindrical surface is rolled out flat. The characters are arranged in 16 vertical rows of 4 characters each. For the sake of explanation, the typewheel is divided into clockwise and counter-clockwise fields to indicate in which direction the typewheel is rotated to select the rows. The rows are then numbered 1 through 8 in each direction from the borderline between the fields. The characters in each row are designated the "1st" through the "4th" from top to bottom.

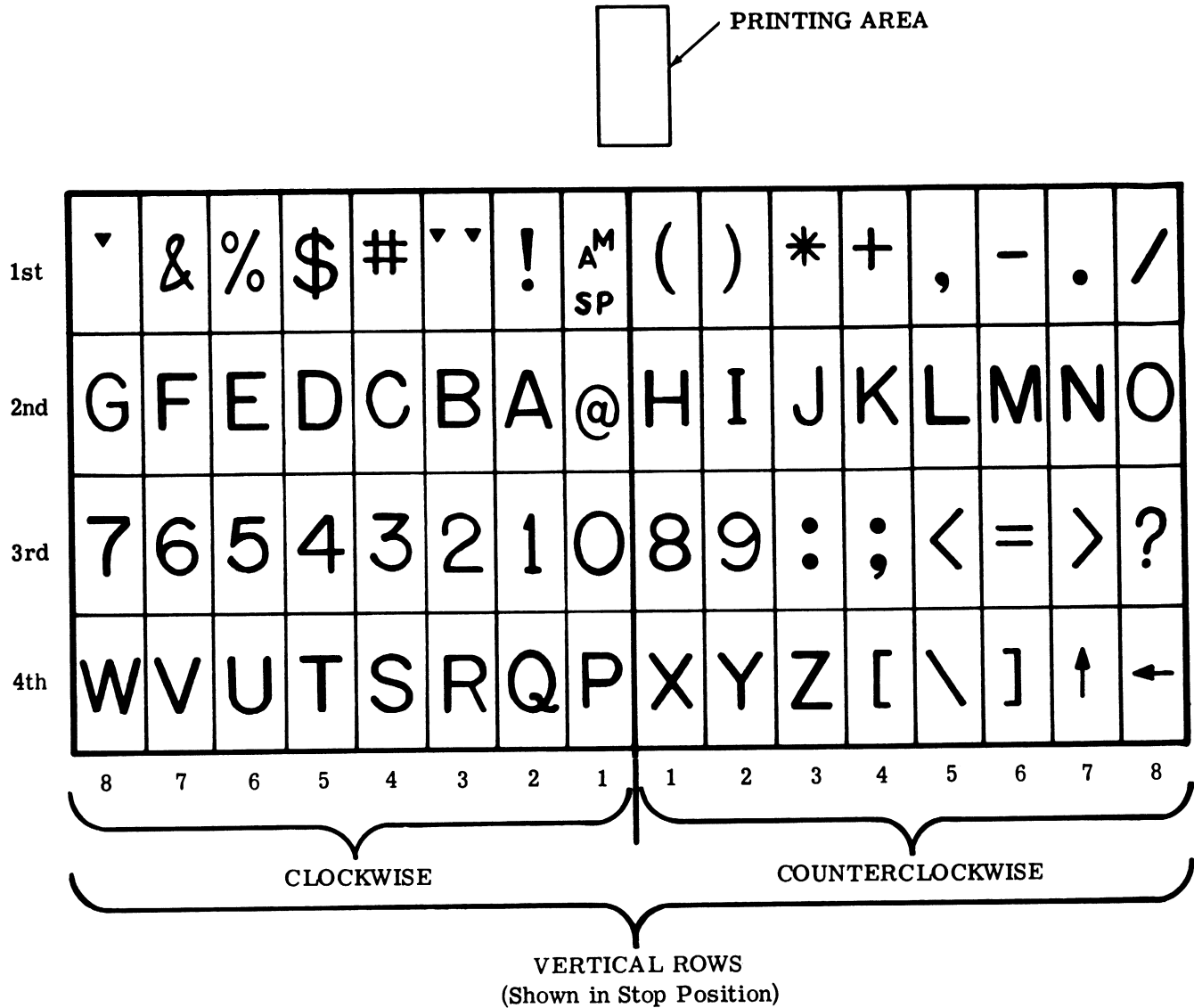

Figure 19 - Typical Typewheel Character Arrangement (As Printed)

4.45 Again for the sake of explanation, a printing area is indicated in Figure 19. This is the area the selected character must be in if it is to be printed when the print hammer strikes the typewheel against the platen. As shown in Figure 19 the borderline between the fields is under the printing area when the typing unit is in the stop condition. During the first part of each function cycle, vertical and rotary positioning mechanisms impart separate but simultaneous motions to the typewheel to select the proper character. The rotary mechanism rotates it either clockwise or counterclockwise to align the proper row with the printing area. The vertical mechanism raises it to place the proper character in the printing area. During

the latter part of the function cycle, the typewheel is returned to its stop position.

Power

4.46 As the function clutch rotates (4.36) an eccentric cam imparts oscillating motion through a carriage drive link to the carriage drive bail (Figure 5). The bail pivots rearward during the first part of the cycle and forward to its stop position during the latter part. In doing so, it causes a power bail on the carriage to pivot first clockwise (as viewed from the left), then counterclockwise (Figure 19). The power bail has two rollers that move along the drive bail and permit it to receive the motion regardless of the carriage position along the printing line.

Rotary Positioning

4.47 The rotary positioning mechanism is illustrated in Figure 20. The direction in which the typewheel rotates from the stop position is determined by the no. 4 codebar. If the no. 4 codebar is marking the typewheel rotates counterclockwise. If it is spacing the typewheel rotates clockwise.

4.48 When a code combination is received in which the no. 4 intelligence pulse is marking, the no. 4 codebar moves up and to the left. A slide mounted on the codebar, through a linkage, pivots the rotary drive arm down. The rotary drive arm has alternate tabs at the end. With the no. 4 codebar marking and the arm pivoted down, the upper left tab engages the left rotary rack. If the no. 4 intelligence pulse is spacing, the no. 4 codebar is down, the rotary drive arm is pivoted up, and the lower right tab engages the right rack.

4.49 A rotary drive bail is held against the power bail by a spring. As these bails rock clockwise (as viewed from the left) during the first part of the function cycle, the drive arm, which is attached to the rotary drive bail, moves toward the front. If the rotary drive arm is down (marking), it pulls the left rack with it, causing a rotary pinion, a cage, a spider, a shaft, and the typewheel to rotate counterclockwise (as viewed from the top). If the rotary drive arm is up (spacing), it pulls the right rack, rotating the pinion, cage, spider, shaft, and typewheel clockwise. As the power bail and rotary drive bail rock back to their stop position during the latter part of the function cycle, two reset blocks on the drive bail return the racks and the typewheel to their stop position.

Degree of Rotation

4.50 How far the typewheel rotates in either direction is determined by the no. 1, no. 2, and no. 3 codebars.

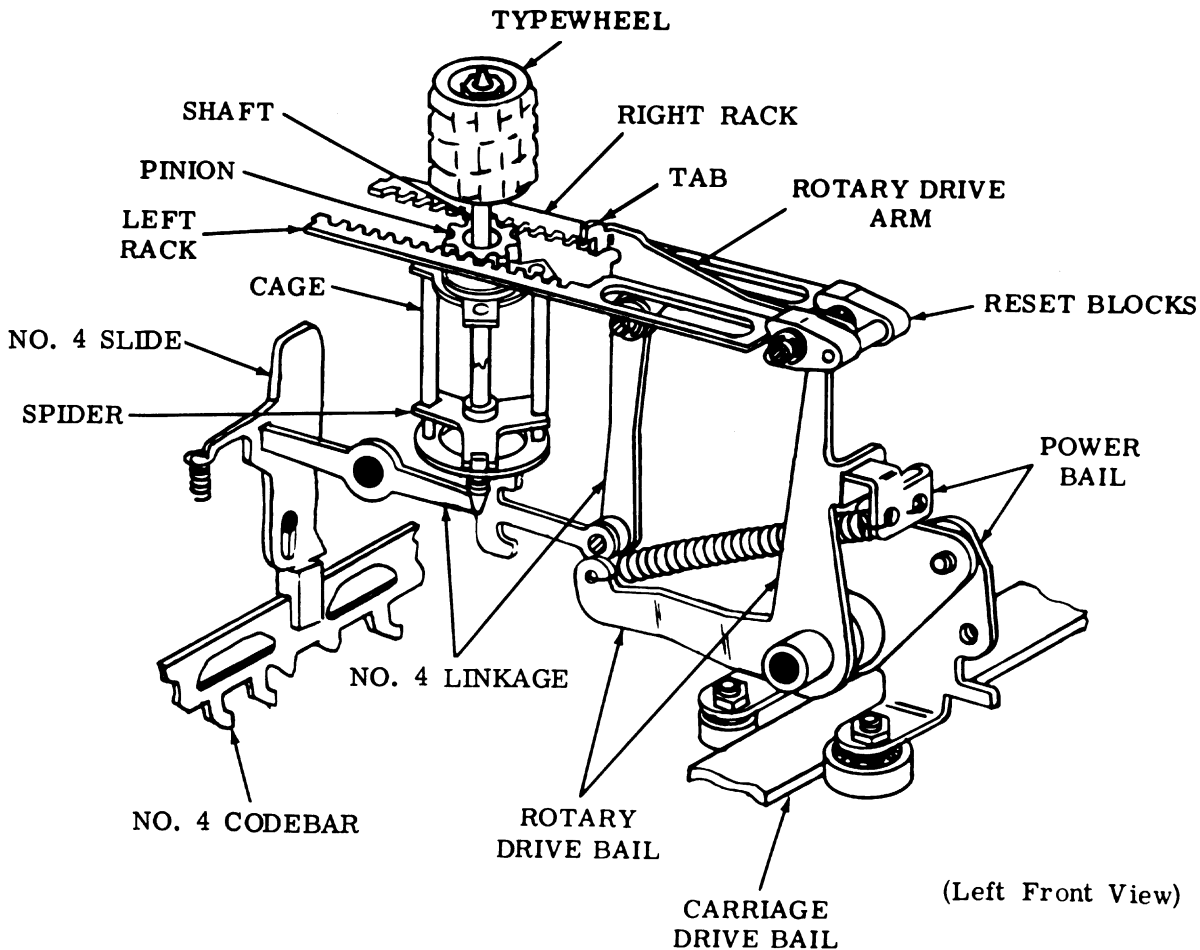

Figure 20 - Rotary Positioning Mechanism

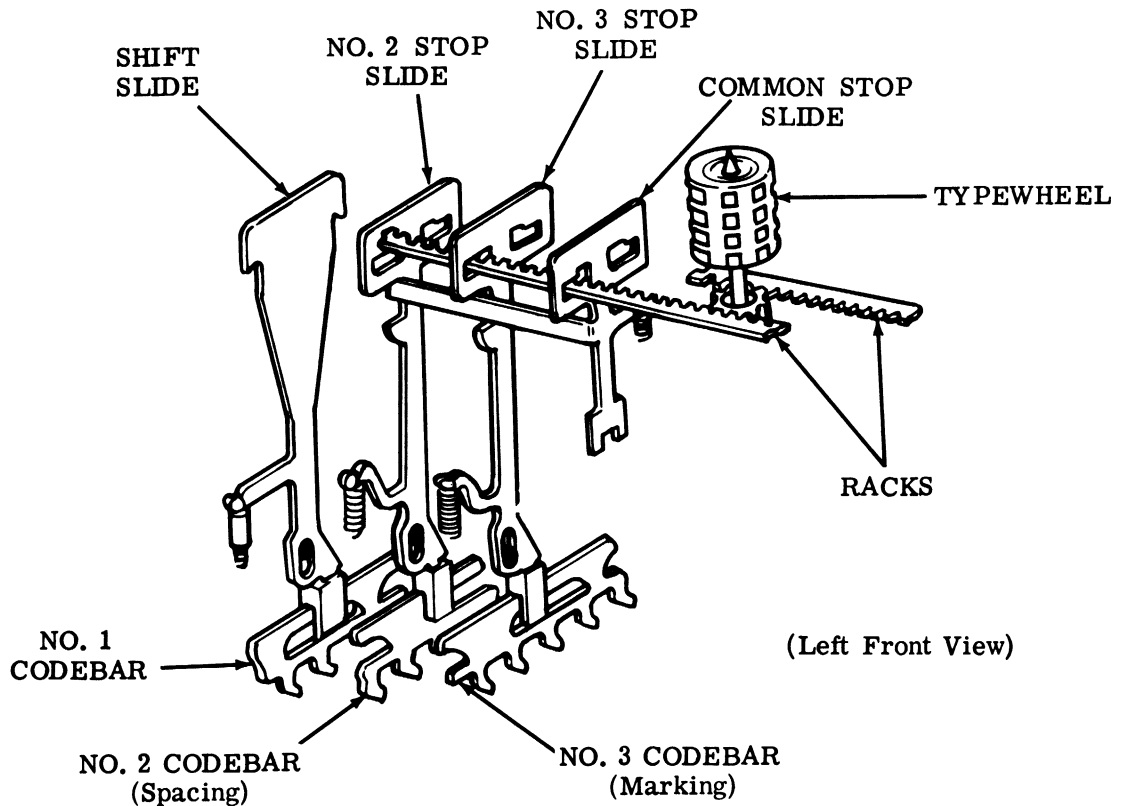

Figure 21 - Rotary Positioning Stop Slides

4.51 The no. 1 codebar controls the position of the shift slide. The no. 2 and no. 3 codebars control the positions of the no. 2, no. 3, and common stop slides. These stop slides ride the codebars and are up when the codebars are marking and down when the codebars are spacing (Figure 21).

4.52 The function of the stop slides is to stop either rack in its rearward travel. When a rack is stopped, the rotary drive bail stops, and the continuing motion of the power bail is dissipated by the spring.

4.53 The position of each stop slide determines how much the rack will travel before it is stopped. When a stop slide is down, it blocks the rack; when it is up, the rack will pass through a slot in the slide and continue to travel until blocked by another slide. The shift slide has no slot. It will block the rack whether it is up or down (Figure 21).

4.54 Depending on the position of the shift slide, the rack will travel to position either the odd or even rows of the typewheel. When the shift slide is up, the even rows are

selected; when it is down the odd rows are selected. As mentioned in 4.51, the shift slide is controlled by the no. 1 codebar.

4.55 When the no. 1 pulse is spacing, the no. 1 codebar and thus the shift slide are down. In this position the shift slide is blocked by the front stop surface of the rotary stop plate (Figure 22). The no. 2, no. 3, and common stop slides remain locked in the slots of the slide guideplate. The corresponding positions of the shift slide, the no. 2, no. 3, and common stop slide will effect 7, 5, 3, and 1 rows of typewheel rotation respectively.

4.56 When the no. 1 pulse is marking, the no. 1 codebar and thus the shift slide are up. In this position the shift slide is up, blocked by the rear stop surface of the rotary stop plate (Figure 22). The two slide guideplates, under spring tension, move to the rear. This positions all four stop slides to the rear enough to reflect one additional row of typewheel rotation. Thus the shift slide, the no. 2, no. 3, and common stop slides will effect 8, 6, 4, and 2 rows of typewheel rotation respectively.

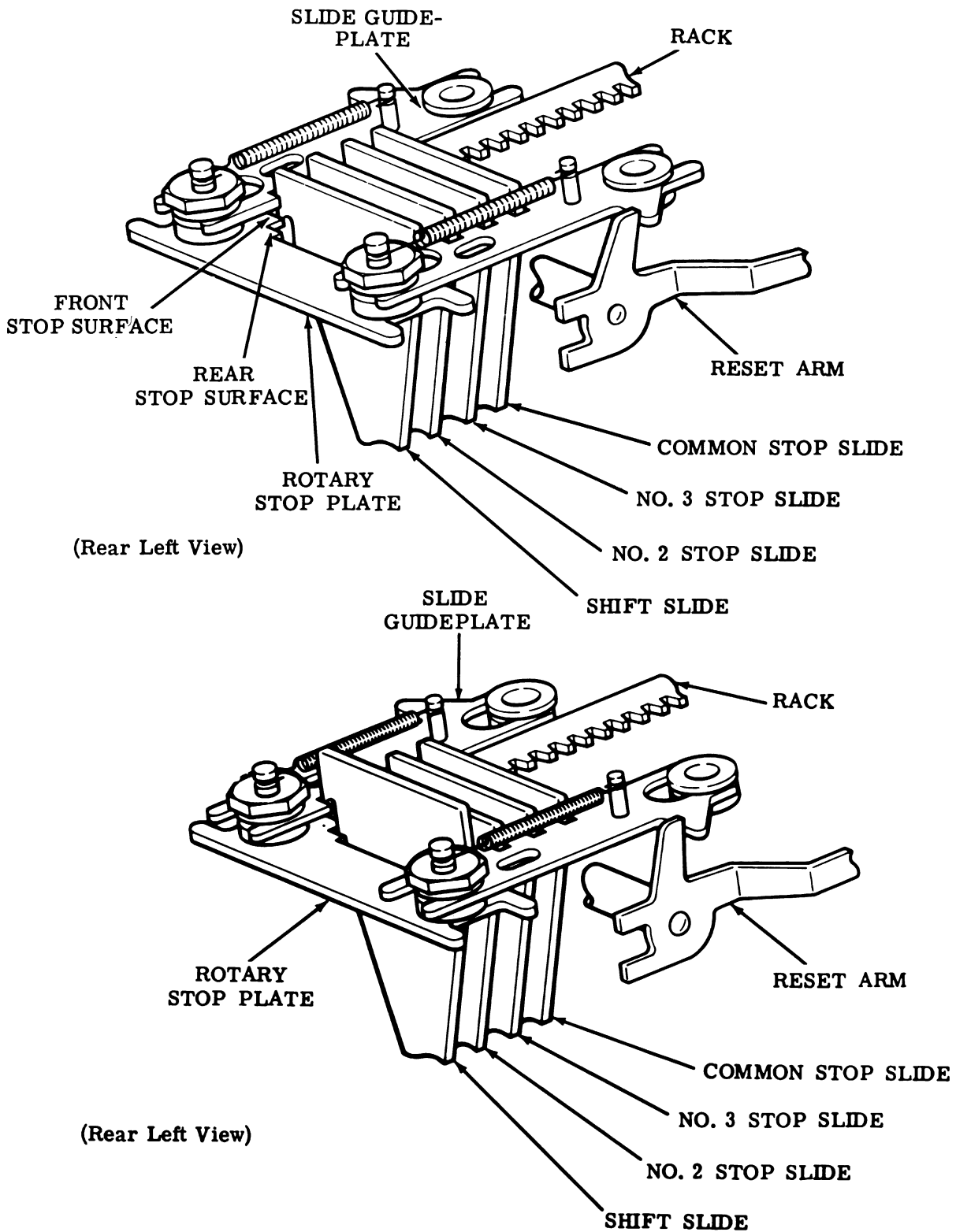

Figure 22 - Rotary Positioning Mechanism

4.57 Following is a summary of marking and spacing conditions for rotary positioning:

(a) Clockwise Field — No. 4 Pulse Spacing

Odd Rows - No. 1 Pulse Spacing

Row 1 — 2 spacing  
3 spacing  
common spacing } stop  
slides

Row 3 — 2 marking  
3 spacing  
common marking

Row 5 — 2 spacing  
3 marking  
common marking

Row 7 — 2 marking  
3 marking  
common marking

Even Rows - No. 1 Pulse Marking

Row 2 — 2 spacing  
3 spacing  
common spacing

Row 4 — 2 marking  
3 spacing  
common marking

Row 6 — 2 spacing  
3 marking  
common marking

Row 8 — 2 marking  
3 marking  
common marking

(b) Counterclockwise Field — No. 4 Pulse Marking

The marking and spacing conditions of the stop slides are the same as for the clockwise field.

**Vertical Positioning**

4.58 The vertical positioning mechanism illustrated in Figure 23 positions the typewheel so that the proper character in the selected row is in the printing area at the time of printing.

4.59 Vertical positioning is determined by the no. 5 and no. 7 codebars with their associated no. 5, no. 7, and common stop arms.

4.60 A vertical drive bail is held against the power bail by a spring. When these bails rock clockwise (as viewed from the left) during the first part of the function cycle, the vertical drive bail, through a drive arm, lifts the spider, typewheel shaft, and typewheel. How far the typewheel is raised is determined by three stop arms that are positioned in response to the no. 5 and no. 7 pulses. When the drive bail encounters an arm, it is stopped and its spring extends as the power bail continues to pivot. The spider moves up and down the bars of the cage, and thus permits rotary motion to be transferred to the typewheel regardless of its vertical position.

4.61 When a code combination is received in which the no. 5 and no. 7 pulses are spacing, the no. 5 and no. 7 codebars and their respective vertical slides remain down, spacing, and no motion is transferred to the stop arms. As the rear extension of the vertical drive bail rises, it strikes the common stop arm, which is the longest. This permits the typewheel to be raised to the point where the first character in the selected row is in the printing area at the time of printing.

4.62 When the no. 5 pulse is spacing and the no. 7 is marking, the no. 7 codebar moves its vertical slide up. The slide pivots the common and the no. 7 stop arm rearward, out of the way of the drive bail. The bail thus strikes the no. 5 arm (the second longest), and the second character in the selected row is placed in the printing area.

4.63 When the no. 5 pulse is marking and the no. 7 is spacing, the no. 5 slide pivots the no. 5 and common stop arms out of the way. The bail strikes the no. 7 stop arm (the shortest) and the third character is placed in the printing area.

4.64 When both the no. 5 and no. 7 pulses are marking, all three stop arms are pivoted out of the way. The bail moves up until it strikes the shoulder on the common stop arm, and the fourth character is placed in the printing area.

**Printing Mechanism**

4.65 After the typewheel has been positioned during the first half of the function cycle, the printing mechanism illustrated in Figure 24 supplies the impact which drives the selected character against the ribbon and paper. Provisions are included whereby printing is suppressed during functions.



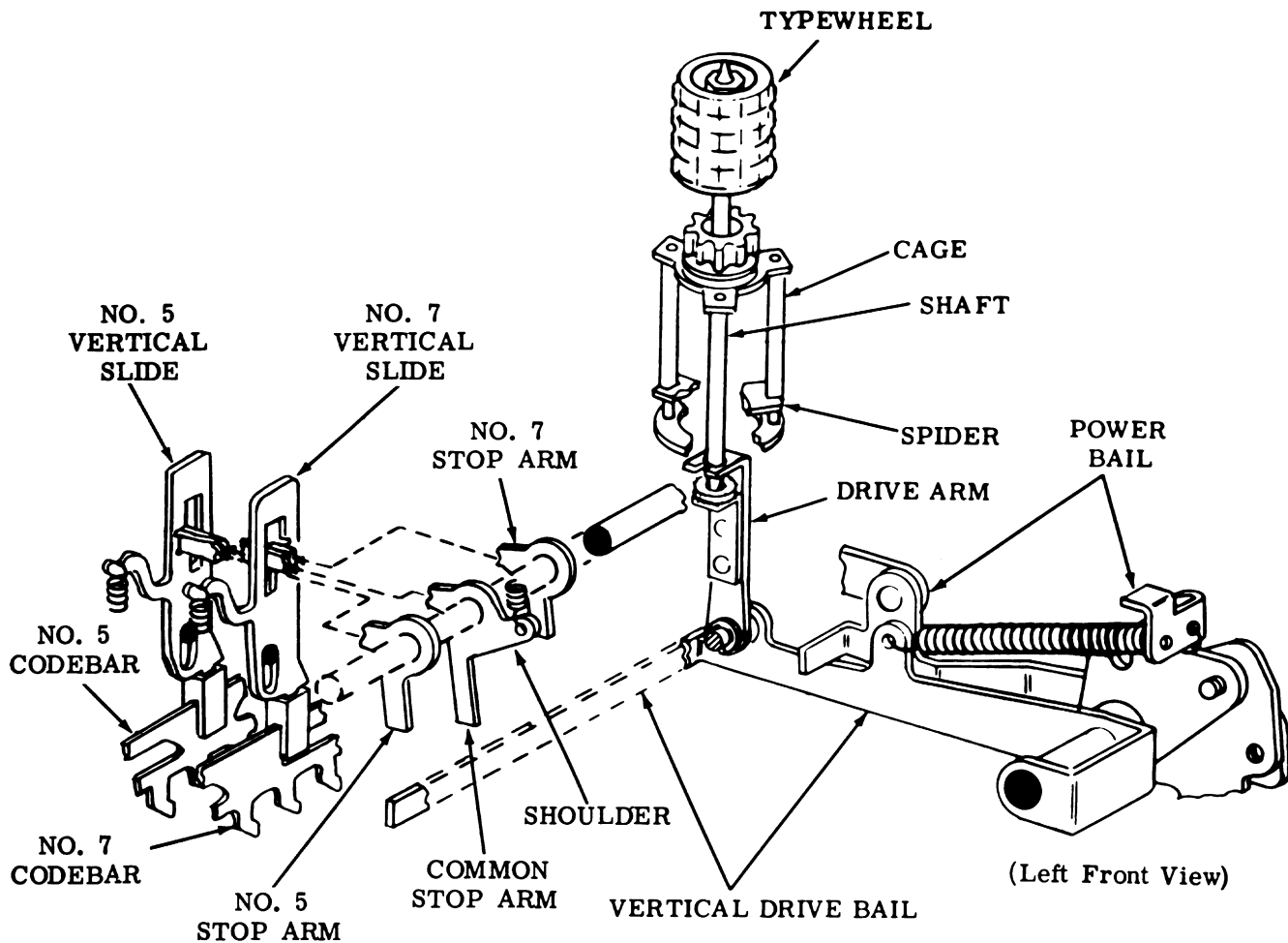

Figure 23 - Vertical Positioning Mechanism

4.66 As the power bail rocks during the first part of the function cycle, it imparts through a link clockwise motion (as viewed from the right) to a print bail. This bail, through a link and pivot shaft, pivots two reset arms. Midway in the cycle, the right arm moves a print trip lever out of engagement with a shoulder on the print hammer bail. A torsion spring snaps the hammer bail rearward, and the hammer drives the typewheel and ribbon against the paper. The lower end of the typewheel shaft pivots on the vertical drive arm and permits the wheel to be driven rearward. The hammer bail has a soft head which strikes the typewheel without damage.

4.67 During the last half of the cycle, the power bail returns the printing parts to their stop positions, and a print reset arm at-

tached to the print bail returns the print hammer bail to its stop position, where it is latched by the print trip lever.

#### K. Printing Suppressed

4.68 The print suppression mechanism (Figure 25) suppresses printing whenever a function code combination is received.

4.69 As the other codebars rise early in the codebar cycle, a print suppression codebar is held down by a print suppression latch. Early in the function cycle, after any of the function levers have been selected, the latch is pivoted away from the codebar by a print suppression cam on the function clutch.

4.70 If no function lever has been selected, the print suppression codebar moves up and to the left to its selected position. A print suppression slide follows the motion of this codebar and pivots a print suppression latchlever out of the way of the shoulder on the print hammer bail. Thus, when the print trip lever releases the bail, its hammer is permitted to strike the typewheel and printing occurs.

4.71 If any function lever moves up to its selected position, it engages one of a series of notches in the print suppression codebar. When the latch releases the codebar, the selected function lever prevents it from moving all the way to its selected position. Thus, the print suppression latchlever is not pivoted and catches the shoulder when the hammer bail is

released by the trip lever. The hammer does not reach the typewheel, and printing is suppressed.

4.72 As the selected function lever moves down and withdraws from the notch in the print suppression codebar, the latch, which has been returned to its stop position, engages a second latching surface on the codebar. This prevents the codebar from rising when the function lever is withdrawn, thus causing printing to occur before the print hammer is completely reset in its stop position. The print suppression codebar is completely reset with the rest of the codebars at the end of the codebar cycle, and at that time the latch engages the first latching surface.

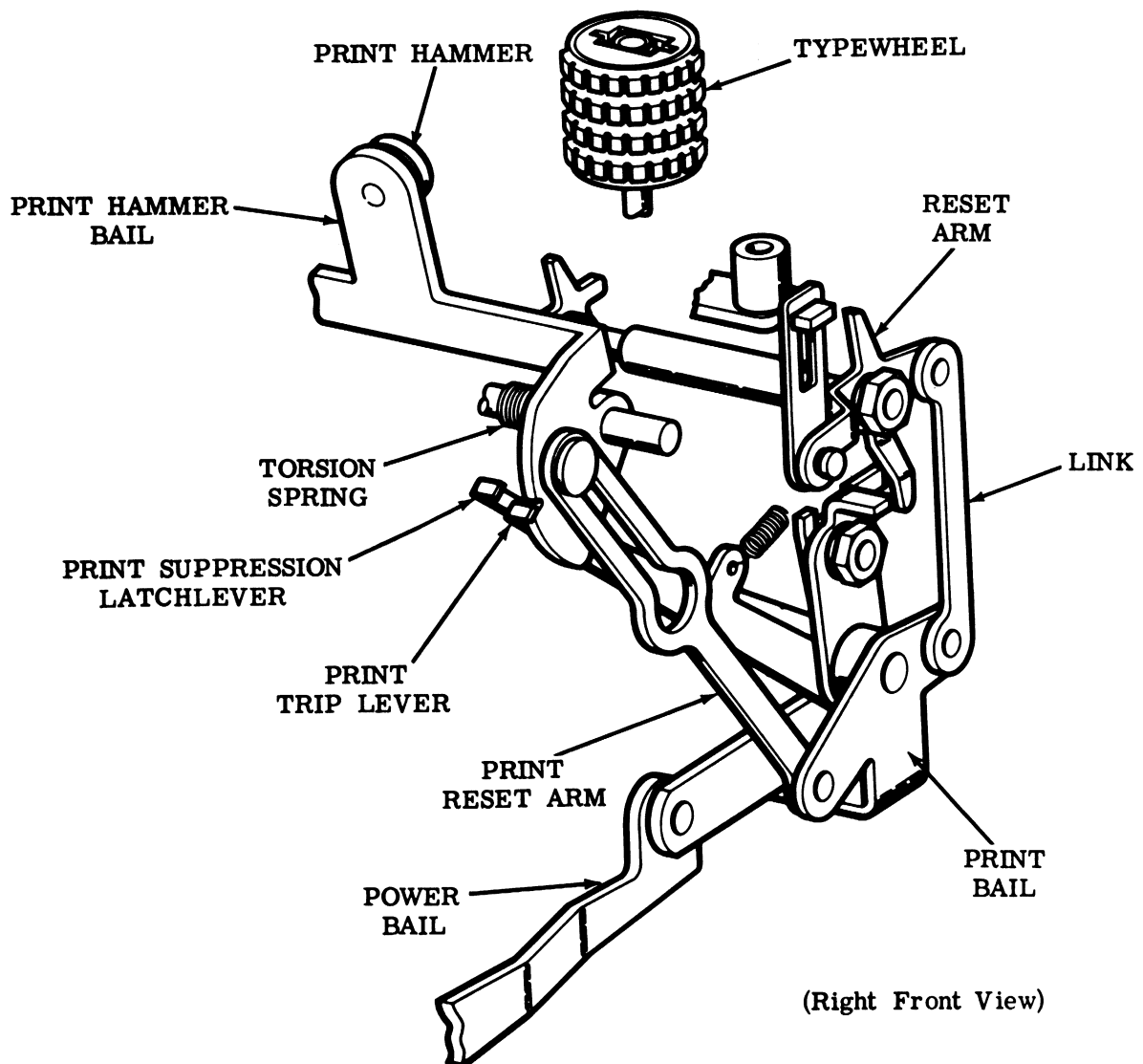

Figure 24 - Printing Mechanism

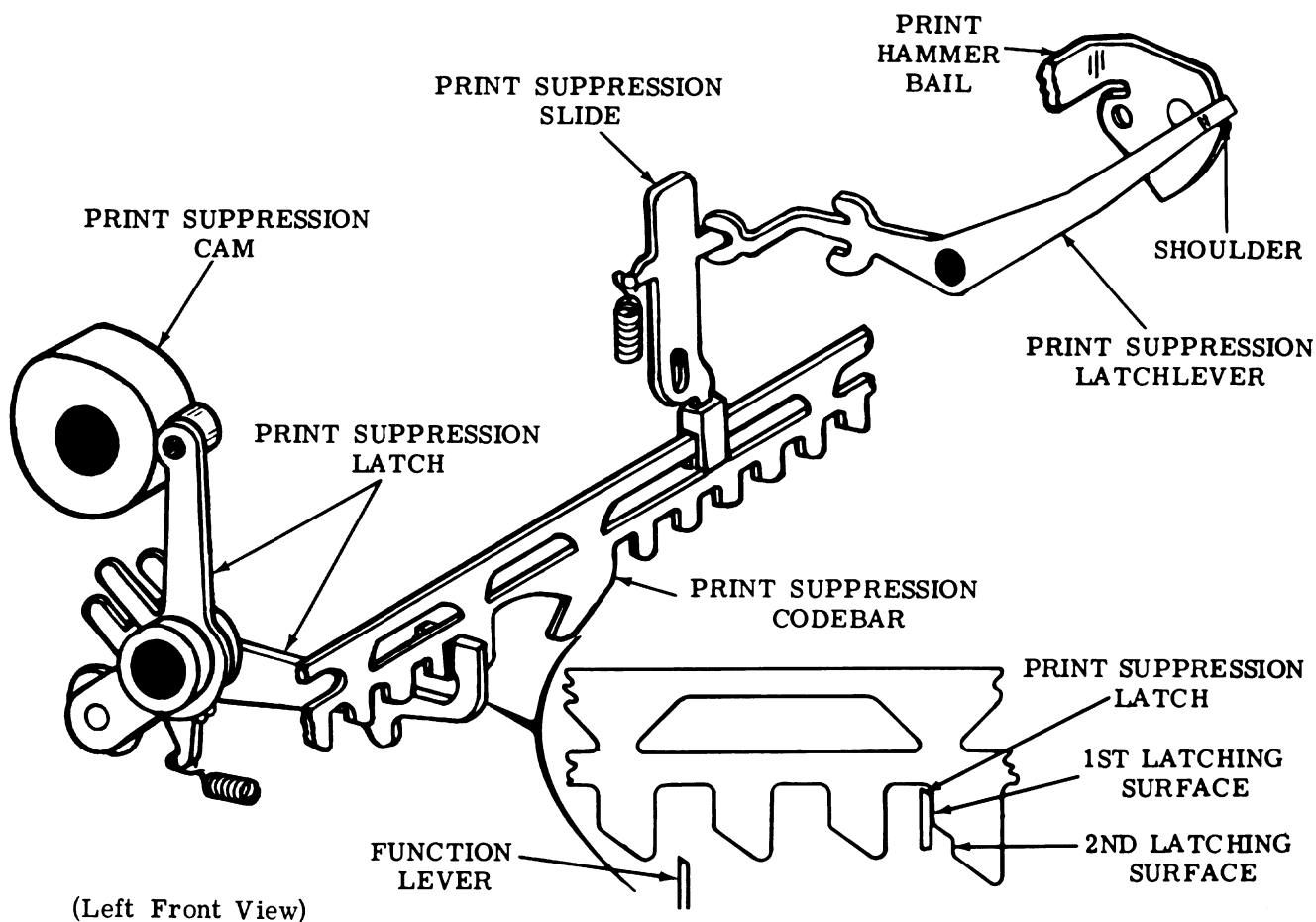

Figure 25 - Print Suppression Mechanism

#### L. Ribbon Mechanism

4.73 The ribbon mechanism (Figure 26) supplies the ink for printing. As the typing unit operates, the mechanism feeds the ribbon from one spool to the other, and reverses the direction of feed when the spool is nearly depleted.

4.74 As the power bail rocks during the first part of the function cycle, it pivots a ribbon power lever which moves a ribbon drive lever rearward. A feed pawl rides on the drive lever and acts on a ratchet to rotate a ribbon spool. A check pawl drops into the succeeding tooth and detents the ratchet until it is again rotated during the next operation.

4.75 The mechanism continues to rotate one spool until the other is nearly depleted. An eyelet in the ribbon then engages the ribbon reversing arm. As the eyelet is pulled against the arm, the latter moves to a point where a detent spring shifts it to its alternate position,

where one of its reversing extensions falls ahead of an extension on the feed pawl. As the pawl moves forward during the last half of the cycle, it strikes the arm extension and is pivoted to its alternate position against the other ratchet. In doing so, it strikes an extension on the check pawl and pivots it to its alternate position against the other ratchet. The depleted spool is now rotated to take up the ribbon until the other spool is nearly depleted, when reversal again takes place.

4.76 The ribbon guide, which is spring biased upward is mounted so that it will slide up and down on posts. As the print pivot shaft turns during the first half of the cycle, the two pivot arms permit the guide to rise so that it is between the selected character and the paper midway in the cycle. At this time the print hammer drives the typewheel and the ribbon against the paper. During the last half of the cycle, the pivot arms retract the guide and ribbon to their stop position so that the printed characters are visible.

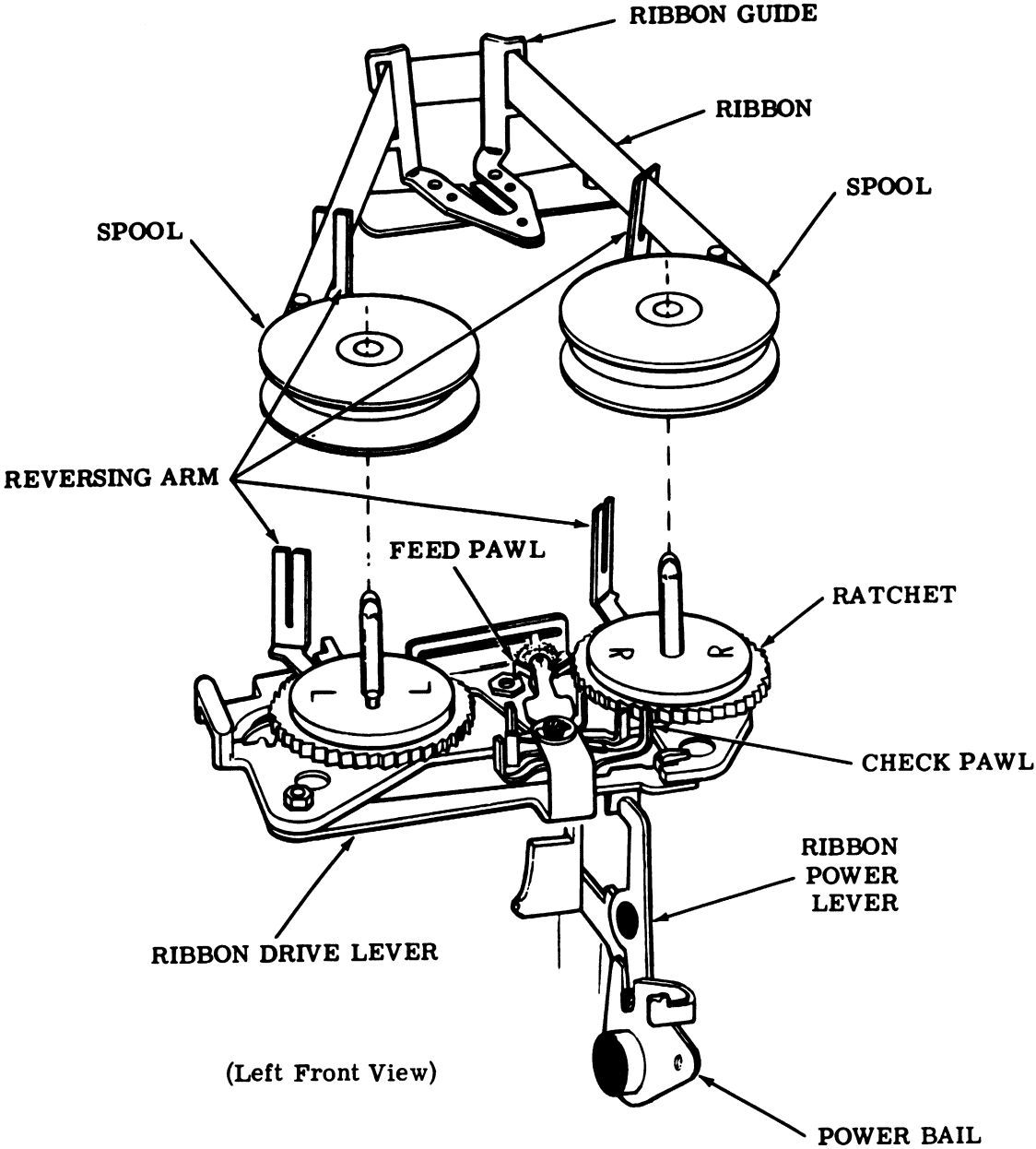

Figure 26 - Ribbon Mechanism

M. Spacing Mechanism

4.77 The spacing mechanism (Figure 27) positions the carriage so that the printed characters are horizontally in line on the paper. Each time a character is printed, the carriage is positioned one character to the right. Spacing is suppressed on all functions except "space" when spacing occurs and printing is suppressed. At the end of the printed line, spacing is sup-

pressed and the typing unit overprints. When the "carriage return" function is received, the carriage is returned to the left margin.

Note: With the automatic carriage return — line feed feature, spacing is not suppressed at the end of a line. Also, the typing unit does not overprint at the end of a line. The carriage is returned automatically to the left margin when it reaches a predetermined point.

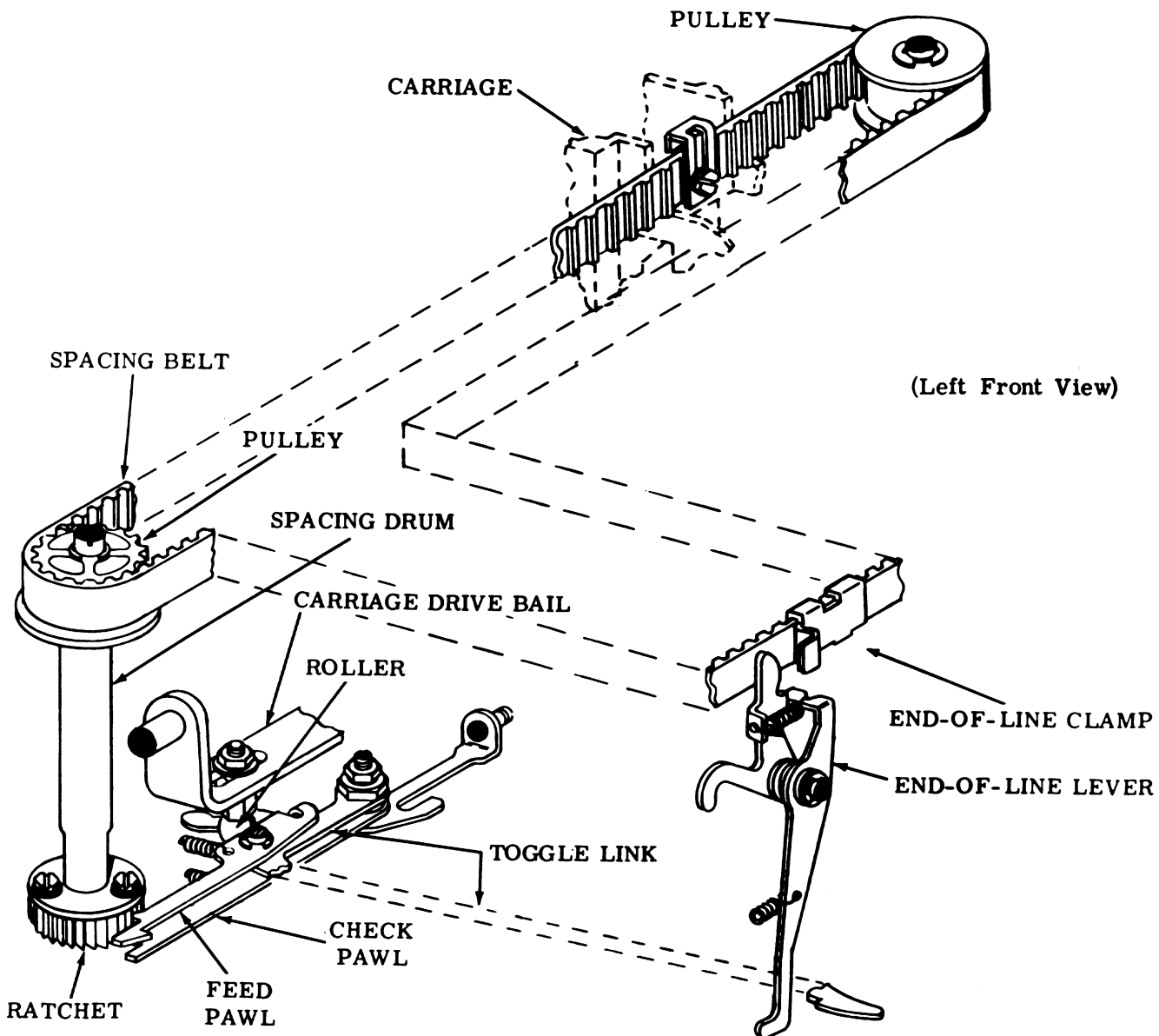

Figure 27 - Spacing Mechanism

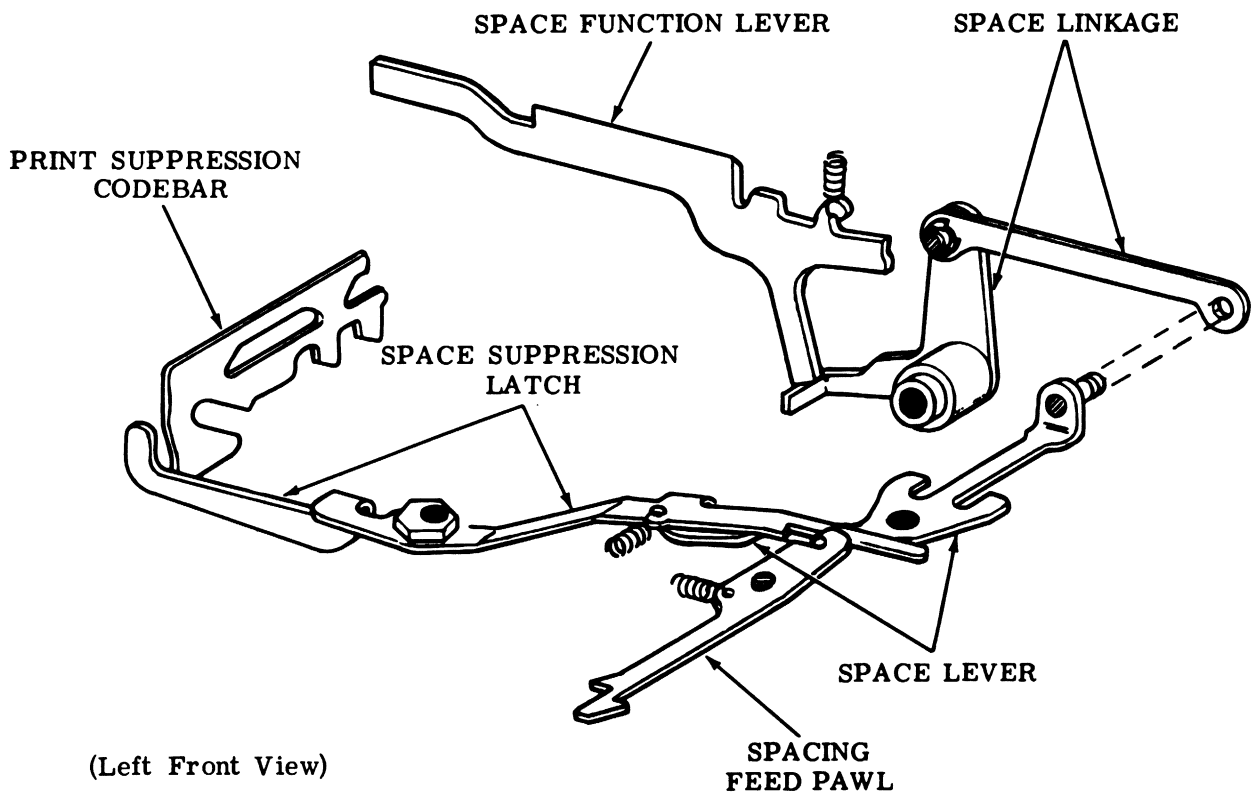

Figure 28 - Space Function and Space Suppression Mechanism

4.78 As the carriage drive bail moves rearward during the first part of the function cycle, a small roller mounted near the left end permits a toggle linkage consisting of a spacing feed pawl and toggle link to buckle rearward under spring tension. The feed pawl moves to the right and engages the next tooth on the ratchet. The ratchet is part of the spacing drum. When the roller moves towards the front during the other part of the cycle, it unbuckles the toggle linkage, and the pawl is moved to the left and rotates the drum one tooth. This motion is imparted by a pulley at the top of the drum to a spacing belt which is looped around a pulley on the right side of the typing unit. The spacing belt in turn moves the carriage to the right one space against the tension of a large carriage return spring. The carriage is held in this position by a check pawl, which engages the spacing drum ratchet.

4.79 When the "space" code combination is received, the codebars permit the space function lever to move up to its selected position early in the function cycle. This motion is transferred, through a space linkage, to a space lever which moves the print suppression latch

out of the way of the toggle linkage. The spacing linkage buckles completely and spacing takes place as described. Printing is suppressed as described in 4.68.

#### N. Space Suppression Mechanism

4.80 On Functions: On every function except "space," spacing as well as printing must be suppressed (Figure 28). When a character to be printed is received, the print suppression codebar moves up and to the left. In doing so it pivots a space suppression latch so that it is moved to the right, out of the way of the toggle linkage. This permits the linkage to buckle and effect spacing.

4.81 On the other hand, when a function is received, the print suppression codebar remains down and to the right, and does not pivot the space suppression latch. In this position, the space suppression latch engages the toggle linkage and prevents it from buckling all the way, and the feed pawl does not move far enough to engage the next tooth. Thus the spacing drum is not rotated, and the carriage is not spaced.

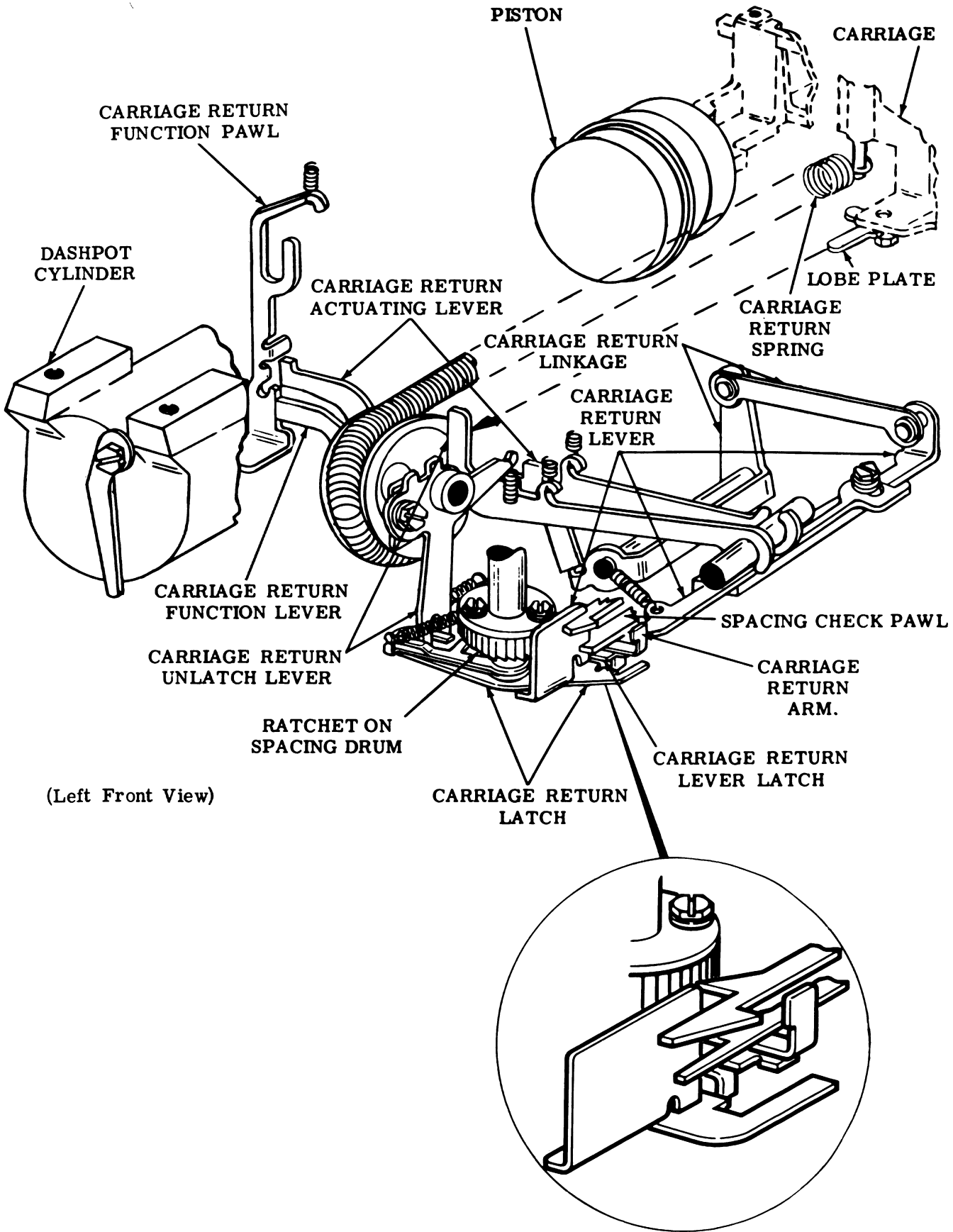

Figure 29 - Carriage Return Mechanism

**4.82 At End-of-Line:** When the carriage reaches the right margin, a clamp on the spacing belt pivots an end-of-line lever counterclockwise. In this position, a latching surface on the spacing toggle link engages the end-of-line lever and prevents the linkage from buckling and effecting spacing. Thus, spacing is suppressed, and the typing unit overprints at the right margin until the "carriage return" code combination is received.

Note: With the automatic carriage return — line feed feature, spacing is not suppressed at the end of a line. Also, the typing unit does not overprint at the end of a line. The carriage is returned automatically to the left margin when it reaches a predetermined point.

#### O. Carriage Return Mechanism

**4.83** The carriage return mechanism is illustrated in Figure 29.

**4.84** When the "carriage return" code combination is received, the carriage return function lever moves up to its selected position, and engages the carriage return function pawl. As the function bail moves the lever and pawl down during the middle portion of the cycle, an extension on the pawl drives the carriage return actuating lever down also. This motion is transferred by means of linkages to the carriage return lever. In moving forward the carriage return lever is latched by both the carriage return latchlever and carriage return latch.

**4.85** In moving forward the carriage return lever also disengages the spacing pawl and check pawl from the spacing drum ratchet. The carriage return spring then pulls the carriage back to the left margin. As the carriage nears the left margin, a lobe plate on the carriage strikes the unlatch lever. This unlatches the carriage return lever and the carriage return latch. However the carriage return lever remains engaged by the latchlever and cannot move to the rear to allow the pawls to engage. When a code combination is received in which spacing is not suppressed, the carriage return lever allows the feed and check pawls to again engage the ratchet. This is accomplished by the feed pawl moving to the right and back to unlatch the carriage return arm and latchlever from the carriage return lever. The latter, under spring tension, moves toward the rear of

the unit allowing the pawls to engage the ratchet. Late in the function cycle the carriage return function pawl is stripped from its function lever by the stripper bail.

**4.86** As the carriage approaches the left margin at relatively high speed, a piston on the carriage enters a dashpot cylinder and compresses the air ahead of it. The air forms a cushion which slows the carriage and then, as it escapes through a small, variable hole at the left end of the cylinder, permits the carriage to be stopped at the left margin without excessive shock.

#### P. Paper or Form Feeding

**4.87** The paper feed mechanism used on friction feed typing units is illustrated in Figure 30.

**4.88** The paper feed mechanism vertically positions the paper so that the printed characters are properly located in lines on the paper. It feeds the paper on receipt of the "line feed" code combination. It may be adjusted for either single or double line feed.

**4.89** The paper feeds off a roll and is led around a platen that vertically positions it in front of the typewheel. A paper guideplate leads it down around the platen. A pressure roller, which sits in a cutout in the guide, holds the paper against the platen so that it feeds when the platen rotates. A curved wire shaft biases the pressure roller and the guideplate against the paper. The pressure is released by a lever on the right end of the shaft. The paper is held around the front of the platen by a wire guide and is led up out of the typing unit by a deflector guide. It can be manually fed by a knob on the left end of the platen.

**4.90** When the "line feed" code combination is received, the codebars permit the line feed function lever to move up to its selected position early in the function cycle. The function lever, in turn, moves up a line feed blocking lever to engage the latching surface of a line feed drive link. As the left drive arm on the function rocker shaft moves down, a line feed arm engages the blocking lever and moves it down. This motion is transferred, through a line feed linkage, to a pawl which engages a ratchet on the left end of the platen. The pawl rotates the platen which feeds the paper up one or two lines depending on how the mechanism is adjusted.



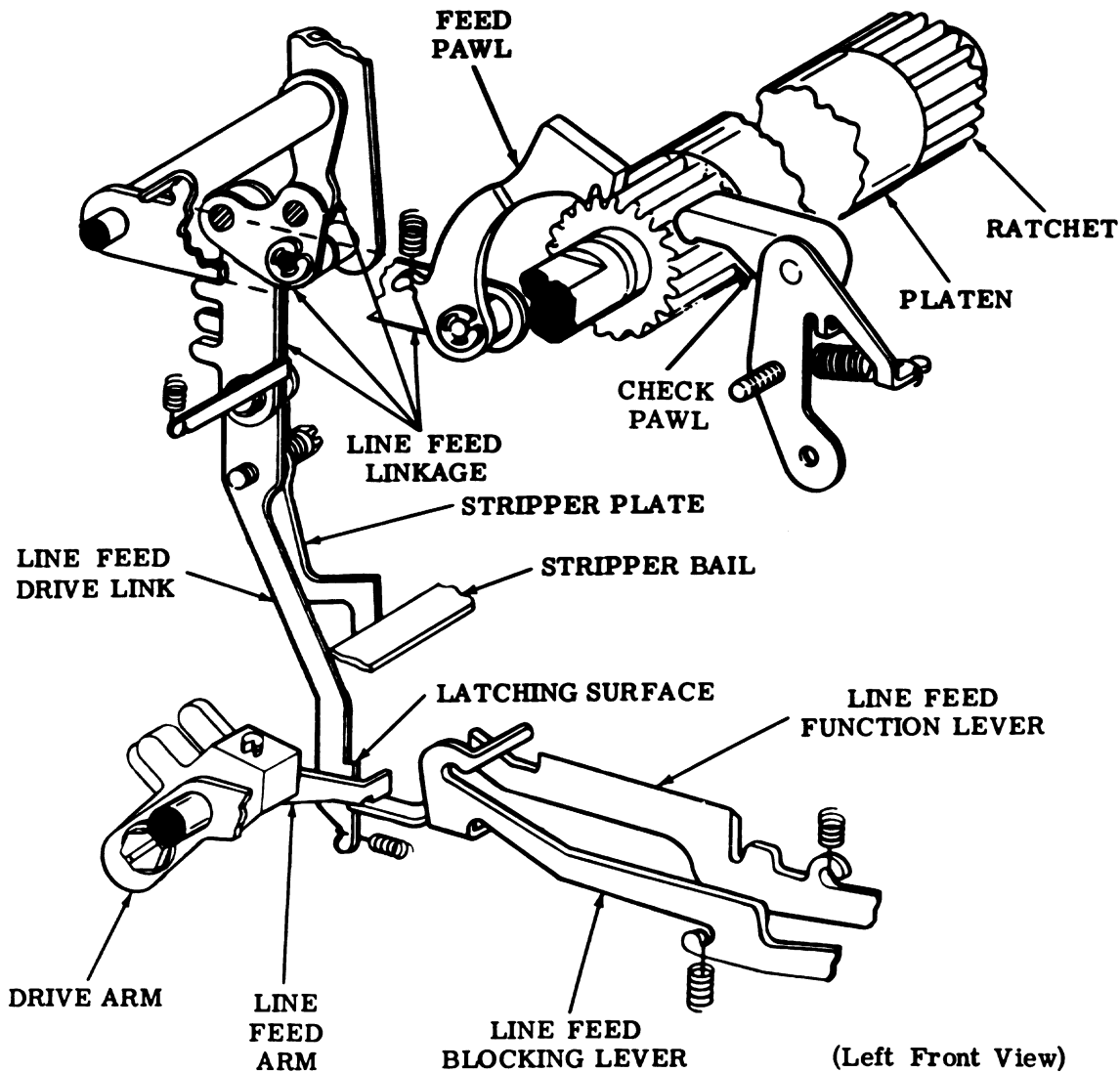

Figure 30 - Paper Feed Mechanism (Friction Feed)

4.91 The feed pawl is guided into the teeth of the platen ratchet by two posts. A check pawl riding on the ratchet at the left side of the platen holds the platen firmly until the platen is again rotated. At the end of the cycle, the function stripper bail contacts a stripper plate and strips the drive link from the blocking lever.

#### Q. Sprocket Feed Typing Units

4.92 The platen drive mechanism (Figure 32) rotates the platen for vertical positioning so that the printed characters are properly located in lines on the forms. The platen drive mechanism is activated through the form-out and form-feed mechanisms (Figures 31 and 33),

and controlled by the form-feed clutch. It feeds forms upon receipt of either the "line feed" or "form out" code combination and may be adjusted for single or double line feed.

4.93 Forms feed from a conveniently located stack of forms. They feed under a paper roll spindle and, if used, a low-paper arm and a paper-out arm. From here, the forms, led by a paper guideplate, engage sprocket pins and advance between the platen and two paper guides until vertically positioned in front of the type-wheel. The two paper guides and a wire guide hold the forms to the front of the platen and insure that the forms advance around the platen while moving up and out of the typing unit. As the forms move out of the typing unit, they go

over the paper roll spindle, which separates incoming from outgoing forms.

**Note:** Forms can be manually fed by depressing the center knob and rotating the platen knob located on the left end of the platen.

**4.94 Form Feed:** When the typing unit receives the "line feed" code combination, the line feed function lever (Figure 31) moves up to engage the line feed function pawl in slot

no. 13. The function pawl, by means of a lug, connects with the line feed strip pawl in the adjacent slot on the function casting (slot M). During the function cycle the function pawl engages and pulls down the strip pawl. The strip pawl pivots the line feed lever. An extension on the line feed lever contacts the trip lever extension which pivots the clutch trip lever away from the shoe lever on the form feed clutch. The clutch engages and the typing unit advances the form for single or double line feed by means of the platen drive mechanism.

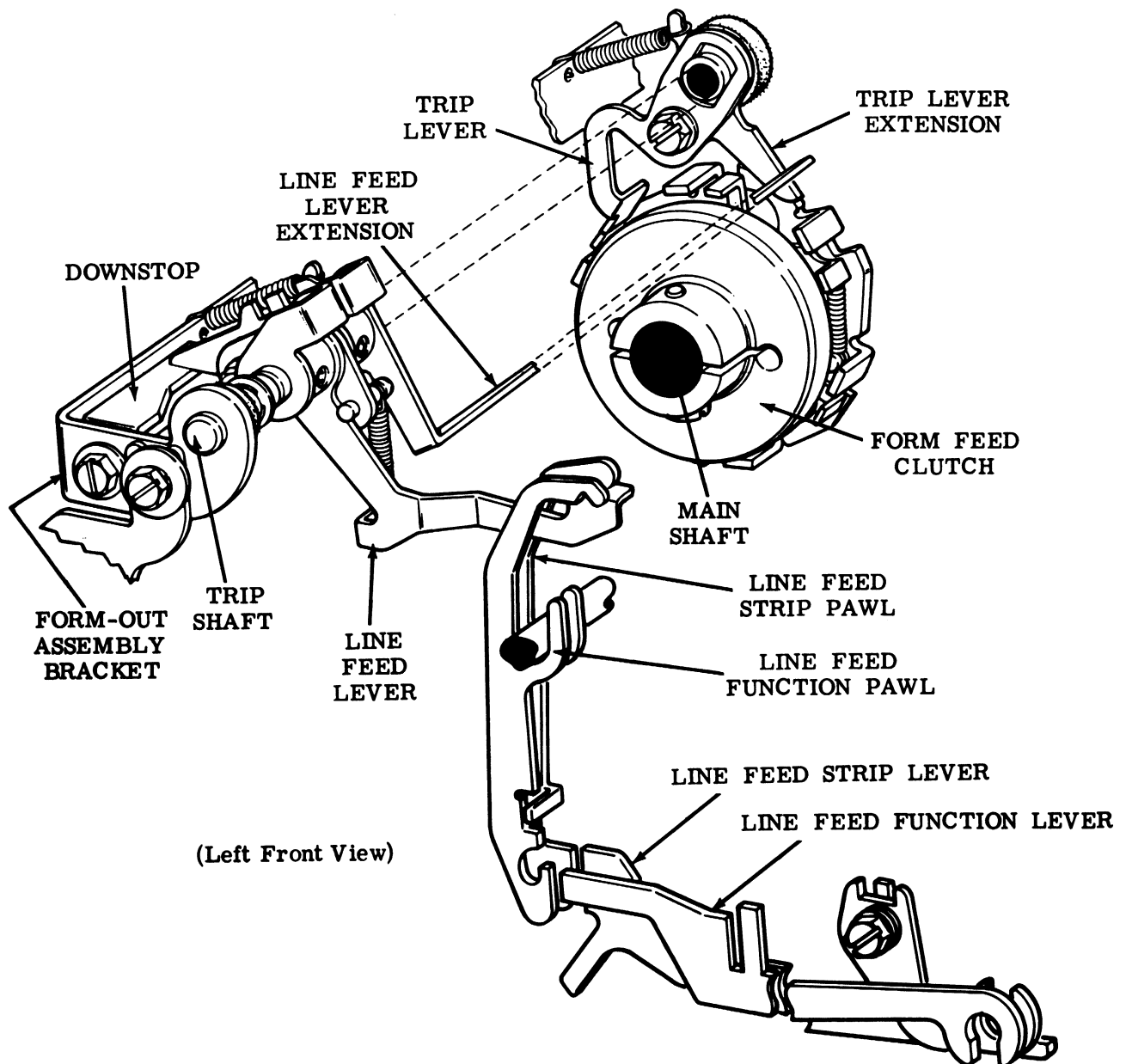

**Figure 31 - Form-Feed Mechanism (Sprocket Feed)**

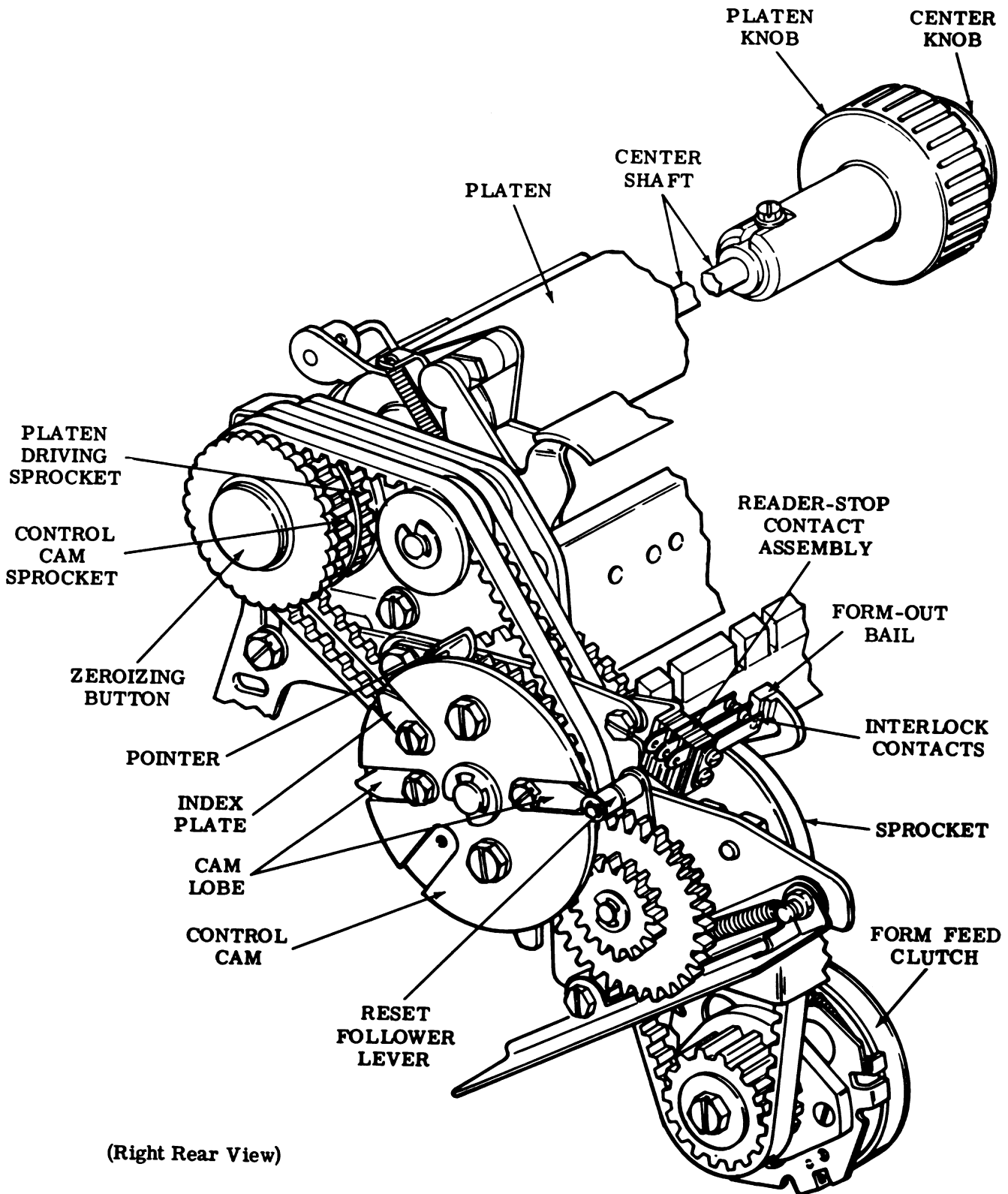

Figure 32 - Platen Drive Mechanism (Sprocket Feed)

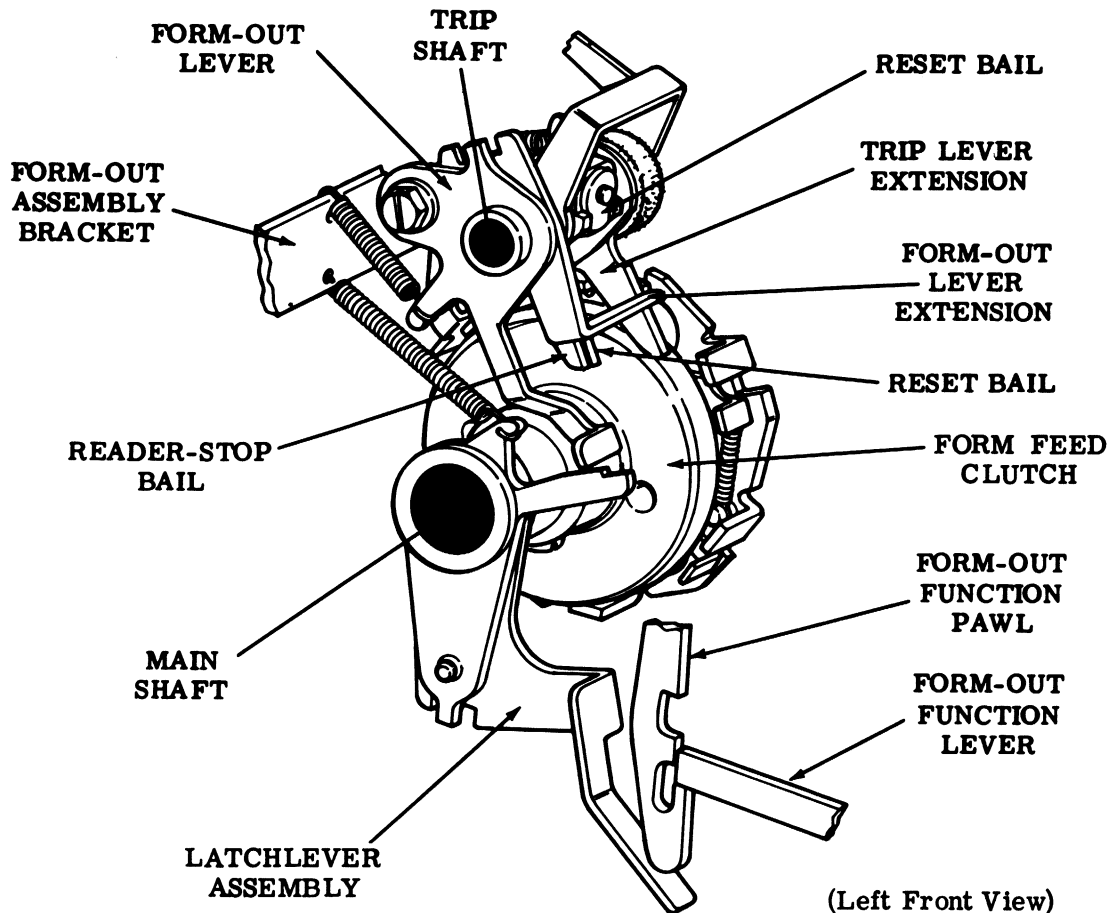

Figure 33 - Form-Out Mechanism (Sprocket Feed)

4.95 Late in the function cycle the strip pawl strikes the tail of the line feed strip lever and moves to the rear. The lug on the strip pawl moves the function pawl to the rear, disengaging it from the function lever. Due to spring tension the line feed lever and its extension return to their front position. The trip lever strikes the clutch shoe lever and the clutch is disengaged.

4.96 The number of lines the form advances depends on how much the clutch rotates before it is disengaged. If the clutch becomes disengaged at the first shoe lever, the form will advance one line; if the clutch becomes disengaged at the second shoe lever, the form will advance two lines; and so on. The amount of clutch rotation depends on how soon the strip pawl comes in contact with the line feed lever. This time will depend upon the distance between the strip pawl and the line feed lever. When the distance is small the clutch will trip and engage sooner, rotating a greater amount before it is disengaged. Double line feed will result. If the

distance is greater the clutch will trip and engage later, rotating a smaller amount before it is latched. Single line feed will result.

4.97 Form-Out: When the typing unit receives the "form out" code combination, the form-out function lever (Figure 33) moves up to engage the form out function pawl in slot no. 14. During the function cycle the pawl is pulled down. This action pivots the latchlever assembly which becomes disengaged from the form-out lever. Due to spring tension the form-out lever pivots to the rear. An extension on the form-out lever pivots the trip lever extension which in turn moves the clutch trip lever away from the clutch shoe lever. The form feed lever engages and remains engaged throughout the form-out cycle.

4.98 When engaged the clutch drives the platen drive mechanism which consists of belts, gears, and sprockets. The platen drive mechanism is illustrated in Figure 32.

## SECTION 574-122-100TC

4.99 As long as the form-out lever stays pulled to the rear by spring tension, the form will advance except as regulated by the control cam of the platen drive mechanism. Whenever the platen rotates, the control cam, being related to the platen by belts and gears, also rotates. The rotating cam, through cam lobes, a reset follower lever, and a reset bail initiates the action to terminate the advance of the platen and thus the form-out cycle.

4.100 When a cam lobe contacts the reset follower lever and rotates it toward the rear, a reset bail also rotates and pivots the form-out lever extension away from the trip lever extension. The trip lever engages a shoe lever and disengages the clutch, terminating form-out.

4.101 With the form-out just terminated the reset follower lever remains on the high part of a cam lobe, and the form-out lever is blocked by the reset bail from rotating to its latched position. When a "form feed" code combination is received, however, the control cam rotates and the reset follower lever moves from the high part of the cam lobe. This causes the reset bail to rotate downward and move away from the form-out lever extension. As a result, the form-out lever is permitted to latch. The typing unit can now receive another "form-out" command.

Note: It is in order to allow the cam lobe to clear the reset follower lever that a "form feed" command is given before another form-out cycle can begin.

4.102 The gearing on the platen drive mechanism varies to accommodate various size forms.

4.103 When the platen drive mechanism advances the form one or two lines during "form feed" the cam lobe rotates an equivalent distance. Then, when "form-out" is received the rest of the form will be advanced with the cam lobe merely rotating until it strikes the reset follower lever.

4.104 The control cam can have three lobes with the result that the form may be advanced one-third the distance for which the gears were installed. For example, if the gears on the platen drive mechanism were designed to advance a form of a certain length, by installing cam lobes, this length can be varied to smaller lengths.

4.105 When an Automatic Send-Receive Teletypewriter Set receives a "form-out" code combination, the form-out bail (Figure 32) is rotated toward the front by the form-out lever extension. This action causes the interlock contacts of the reader stop contact assembly to be operated with the following results:

(a) A pair of normally closed contacts are opened during the "form-out" function. This stops the tape reader from transmitting and prevents characters "on the fly" from being printed.

(b) A pair of normally open contacts are closed. This keeps the typing unit motor operating in case the typing unit is turned off before the form-out cycle is completed. Thus, synchronization of the forms is maintained.

4.106 The form can be manually advanced any length by pressing the zeroizing button on the platen (Figure 32). This will disengage the platen from the platen drive sprocket and allow it to rotate freely.

### R. End of Line Bell

4.107 As the carriage moves to the right during printing, the carriage upper rear roller makes contact with and depresses a latch which is secured to a lever mounted on the rear rail. As the latch is depressed, the lever is rotated and moves the automatic carriage return — line feed codebar to the right a short distance, where a notch in the codebar permits the bell function lever to move up to its selected position, where it is latched by its function pawl. During the middle portion of the function cycle, the lever moves the pawl down against the pressure of the latter spring. When the stripper bail strips the pawl late in the function cycle, the pawl moves up and causes a clapper mounted on a wire spring to snap up and ring a gong.

Note: An alternative method of performing the same operation proceeds in the same manner as above, except that a projection on the carriage picks up the automatic carriage return-line feed codebar at a predetermined point and moves the codebar to the right a short distance until a notch in the codebar permits the bell function lever to move up to its selected position.

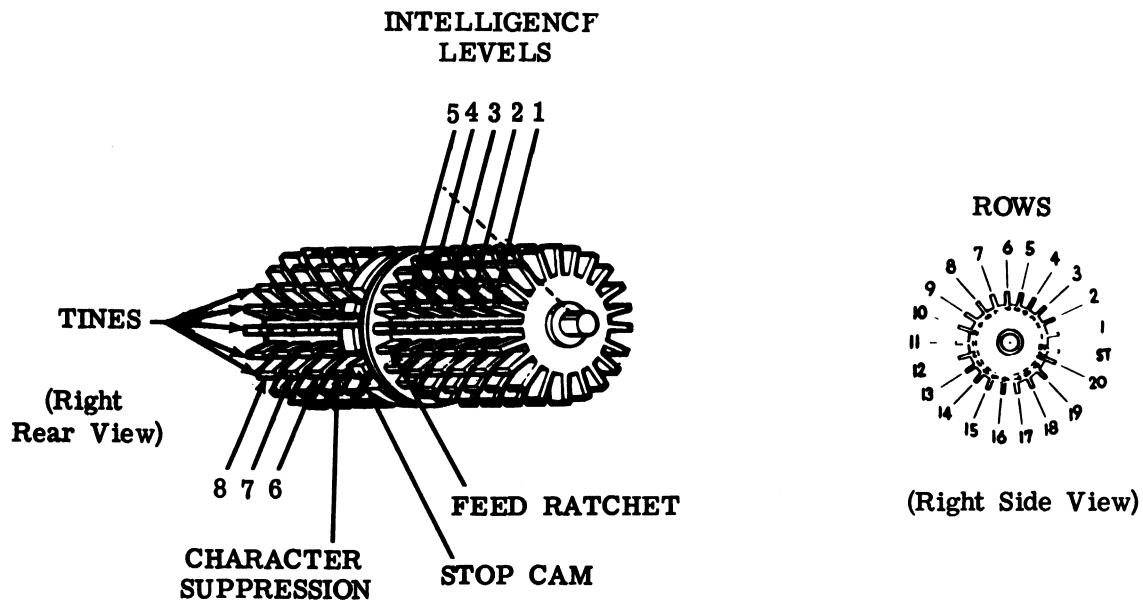

Figure 34 - Answer-Back Drum

#### Automatic Carriage Return-Line Feed

4.108 As described for the alternate method in the note above, the carriage picks up the automatic carriage return-line feed codebar at a predetermined point and moves it to the right. When the carriage reaches the right margin, a notch in the codebar permits an automatic carriage return-line feed function lever to move up to its selected position, where it is latched by its function pawl.

4.109 The automatic carriage return-line feed function lever, in turn, moves the line feed blocking lever up to where it is latched by the line feed link. Line feed then occurs as described in 4.87 through 4.91 and 4.94 through 4.96.

4.110 When the automatic carriage return-line feed function lever and its function pawl are pulled down during the middle portion of the cycle, the pawl encounters an extension on the carriage return function pawl and moves it down. Carriage return then occurs as described in 4.83 through 4.86.

#### S. Answer-Back Mechanism

4.111 The answer-back mechanism illustrated in Figures 35, 36, and 37 automatically transmits a predetermined sequence of characters for identification purposes.

4.112 A drum is coded with characters making up the answer-back sequence. When the answer-back mechanism is actuated, it rotates the drum, which sets up the code combinations in a set of answer-back contacts. The distributor converts the positions of the contacts to start-stop signals for transmission. After the answer-back sequence has been transmitted, the answer-back mechanism returns itself to its unoperated condition. For reasons that will be described, provisions are made for shunting the signal line during sensing of the first answer-back character of each cycle; and to prevent the answer-back from being actuated by the local generation of the answer-back call character.

4.113 The answer-back drum illustrated in Figure 34 has 11 levels as follows:

- (a) Five numbered levels
- (b) Feed ratchet
- (c) Stop cam
- (d) Character suppression
- (e) Three more numbered levels

4.114 Viewing it from the numbered end, the answer-back drum has 21 rows, ST (start) and 1 through 20. The feed ratchet serves to rotate the drum. The stop cam has tines

SECTION 574-122-100TC

which can be removed at various points so that the length of the answer-back message can be varied. The character suppression level is used to shunt the first answer-back character from the signal line. By breaking off tines in the various rows at the numbered intelligence levels, the drum may be coded to generate the proper answer-back characters. For example, if the first character of an answer-back message to be transmitted is the letter D code combination (--3---7-), tines at the no. 3 and no. 7 levels should be broken off in the appropriate row where the answer-back message is to start. The second character of the message would be coded into the next succeeding row.

Note 1: All answer-back messages should be preceded by the "carriage return," and "line feed" code combinations.

Note 2: For details on answer-back drum coding refer to the adjustment Section 574-122-700TC.

4.115 The answer-back mechanism can be actuated in three ways.

- (a) Remotely, by the reception of a pre-determined call character.
- (b) Locally, by depressing the HERE IS key.
- (c) Automatically, by actuating the answer-back trip magnet mechanism from some external equipment, such as a data set.

4.116 Remote Actuation (Figure 35): When the answer-back call character is received by the typing unit, the answer-back function lever moves up to engage its function pawl. As the function lever and pawl are moved down by the function bail, the pawl pivots the answer-back bail. In pivoting, the answer-back bail moves a trip link frontward. The trip link pivots the control lever out of the indentation on the stop cam. The control lever, through the stop bail, moves the trip lever rearward, out of engagement with the shoe lever, allowing the distributor clutch to engage.

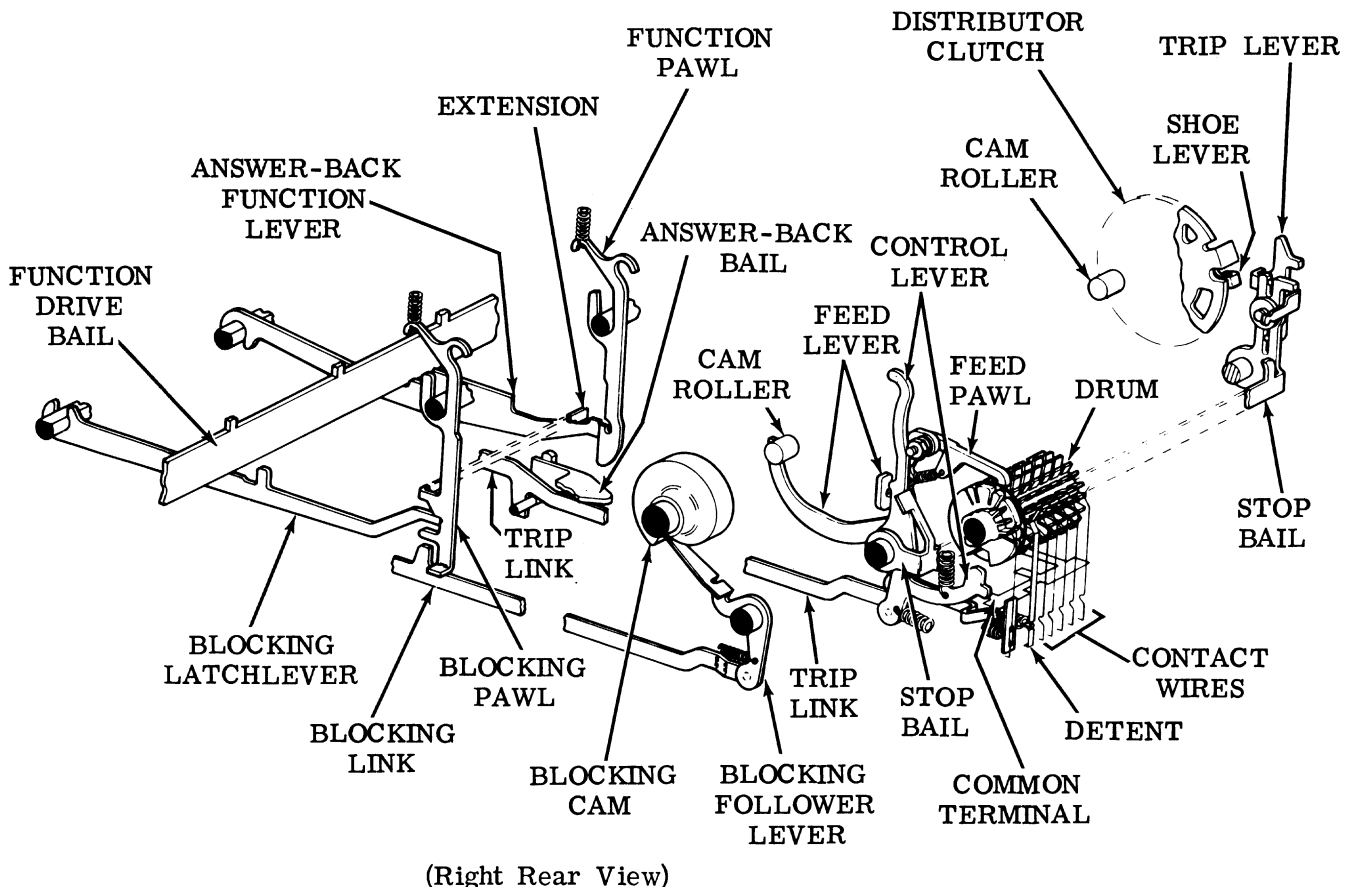

Figure 35 - Answer-Back Mechanism Remote Actuation

4.117 When the distributor clutch begins to rotate, a cam roller moves up and permits the feed lever to pivot rearward against the control lever. The feed pawl attached to the feed lever moves rearward to engage the next tooth on the drum ratchet. Near the end of the function cycle the function pawl is stripped from its function lever by the stripper bail. The control lever, under spring tension, tends to return to its unoperated position in the indentation of the stop cam. This would terminate the answer-back operation by disengaging the distributor clutch. However, since the feed pawl is engaged with the next tooth on the ratchet, the spring tension on the control lever is not enough to overcome the combined tension of the feed lever spring and the drum detent. Thus the mechanism remains in its operated condition throughout the distributor cycle.

4.118 Near the end of the distributor cycle, the cam roller on the distributor clutch moves the feed lever and feed pawl frontward, and the pawl acts on the ratchet to rotate the drum one tooth. The stop cam on the drum now prevents the control lever and trip lever from returning to their stop position. The distributor clutch thus continues to cycle and rotates the answer-back drum.

4.119 The answer-back contacts are wired in parallel with the keyboard contacts to the segments of the distributor disc. As the drum rotates during the answer-back operation, the contact wires, under spring tension, sense each row of tines. If a tine has been broken off at a given level in a row, the associated wire moves frontward to its marking position against a common terminal. On the other hand, if a tine is present, it holds the wire away from the terminal in its spacing position. As the distributor clutch cycles, the distributor converts the positions of the contacts to sequential start-stop signals for transmission.

4.120 The drum continues to rotate until the next indentation in the stop cam is presented to the control lever. The latter then moves into the indentation and returns the associated parts to their unoperated position. The shoe lever then strikes the trip lever and disengages the distributor clutch. The mechanism is thus returned to its unoperated condition.

4.121 Local Actuation: When the HERE IS keytop is depressed on the keyboard, it pivots a bellcrank which moves the trip link

frontward. The trip link pivots the control lever to its operated position and the answer-back proceeds as described in remote actuation (4.116).

4.122 Automatic Actuation: The answer-back mechanism of a distant station may be actuated by completing a connection through the local data set or some other equipment. The trip magnet on the distant station is energized. Being energized it attracts the trip magnet armature which allows the trip lever to move frontward. A tab on the trip lever pivots the control lever out of the indent of the stop cam allowing the clutch to engage. As the clutch rotates the blocking cam also rotates. A blocking follower rides the blocking cam and rotates clockwise. By means of a tab the blocking follower rotates the trip lever which latches against the de-energized armature extension. It remains in this position until the magnet is again energized.

4.123 Since the answer-back, keyboard, and tape reader (where used) contacts are wired in parallel with the distributor disc, the answer-back contacts must all be in their spacing position when the mechanism is unoperated, so that they do not interfere with keyboard or tape reader transmission. Therefore, because the answer-back feed mechanism does not feed the drum until near the end of the first cycle, the first character sensed should be all spacing to prevent garbling of the regular message sent from the keyboard and/or tape reader. However, an all "spacing" character is undesirable in some systems. Therefore, a way is provided for shunting transmission from the signal line during the sensing of the first answer-back character.

4.124 As mentioned, the trip link moves frontward when the answer-back sequence is initiated and remains there until it is terminated. In this position it permits a character suppression contact wire to sense the drum character suppression level. The character suppression contact is wired so that it shunts transmission from the outgoing signal line when it is closed. The tine at the character suppression level of the first character of each answer-back cycle must always be broken off in order to accomplish this. Thus the character suppression contact wire is selected and keeps the line marking until the second character is sensed. The tines are left in the character suppression level in other rows, except for certain conditions, such as to correct coding



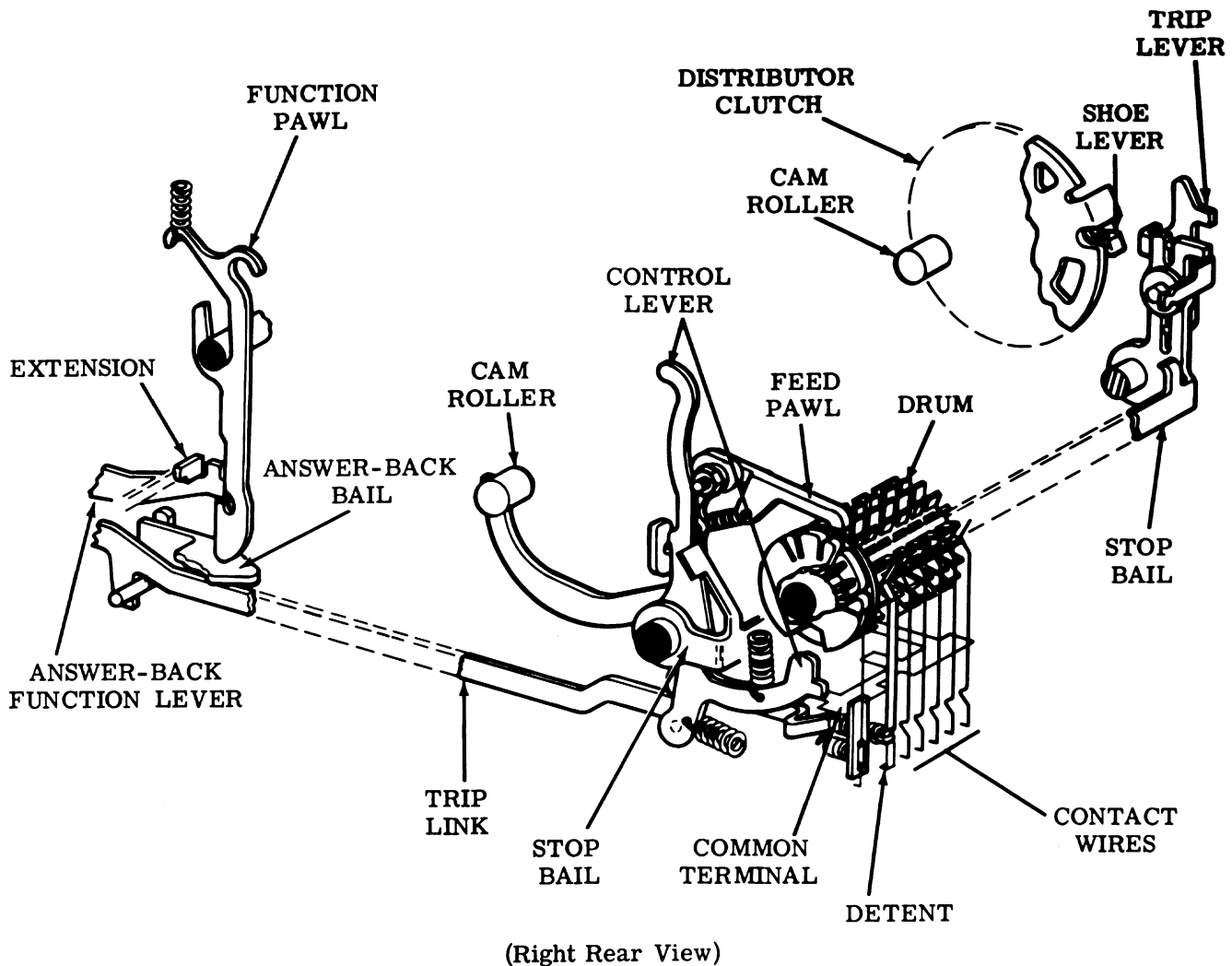

Figure 36 - Answer-Back Mechanism Local Actuation

errors and to vary the message length. This allows, in effect, one character delay before the message coded into the answer-back drum is transmitted. At the end of the operation, the trip link again moves rearward and holds the contact wire unselected while the mechanism is unoperated.

4.125 Answer-back Suppression on Transmission: Since the typing unit receives every code combination that it transmits, the sending of the answer-back call character would actuate the local answer-back as well as the one at the distant station. To prevent this, a blocking mechanism prevents the

function mechanism from operating in the answer-back area during transmission.

4.126 As the distributor clutch rotates, the blocking cam pivots the blocking follower lever which pulls a blocking link rearward. The link pivots the blocking pawl rearward until it releases a blocking latchlever which, under spring tension, moves up against the function drive bail. When the function drive bail and the blocking latchlever move up during the function cycle, the blocking latchlever cams the blocking pawl further rearward where an extension on the pawl is over an extension on the answer-back function lever. The function lever is thus pre-

vented from moving up far enough to be latched by its pawl and initiate the answer-back sequence.

4.127 During the latter part of the distributor cycle, the blocking cam allows the blocking link to move forward to its unoperated position. As the function drive bail moves down during the middle portion of the function cycle, it drives the blocking latchlever downward to the point where the blocking pawl is permitted to pivot forward to its unoperated position. Thus

every time a character is initiated locally, the distributor clutch cycles and operates the blocking mechanism which prevents the answer-back function lever from sensing the codebars and initiating the answer-back sequence regardless of what character is processed by the typing unit. On the other hand, when remotely initiated characters are received, the distributor clutch does not cycle, the blocking mechanism is not operated, and the function lever is permitted to sense the codebars and initiate the answer-back sequence upon receipt of the predetermined call-character signal.

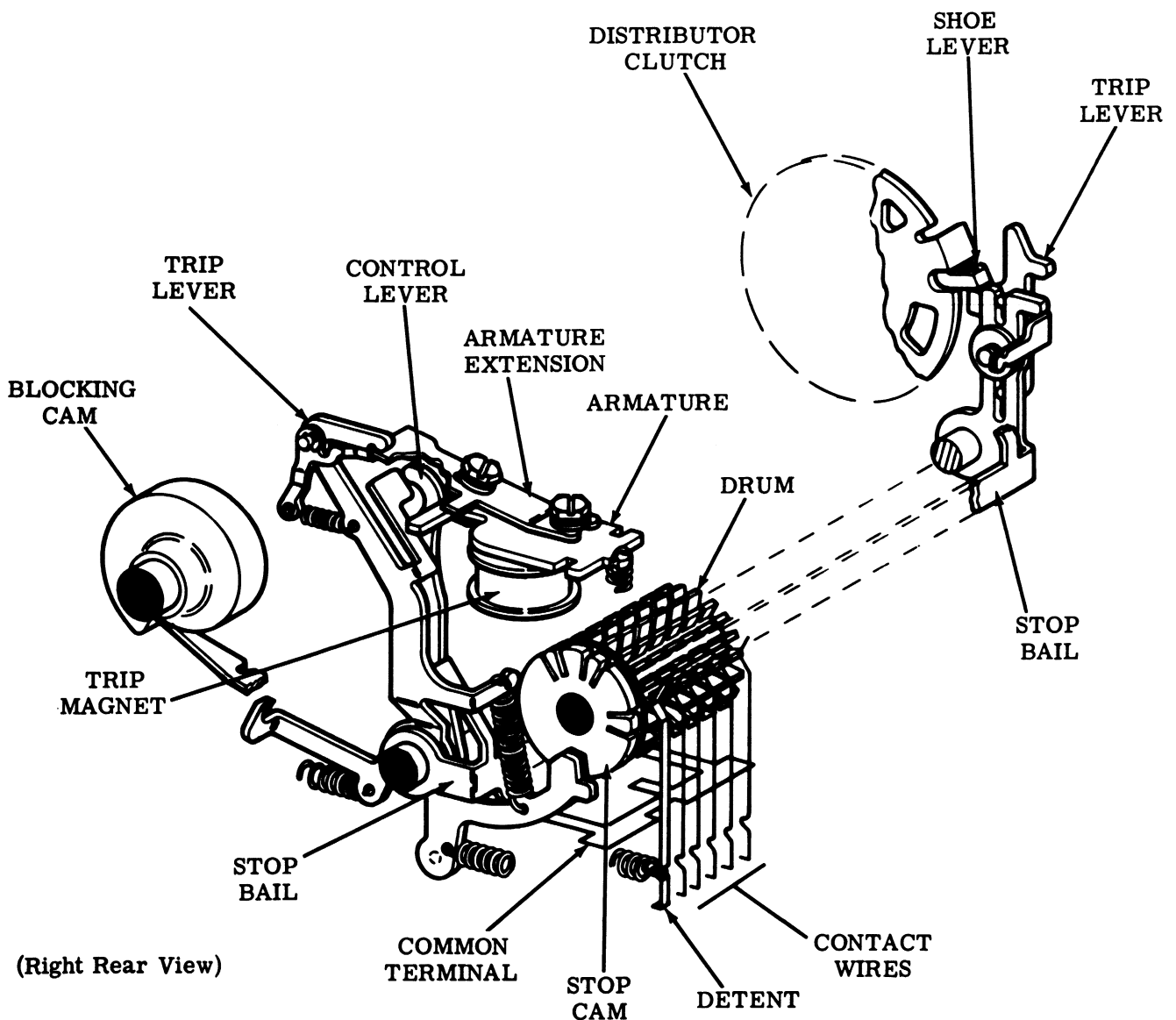

Figure 37 - Answer-Back Mechanism Automatic Actuation

4.128 The length of the answer-back sequence can be varied either by altering the stop-cam level or the character-suppression level.

(a) Stop Cam: The answer-back mechanism can be coded for either 1-, 2-, or 3-cycle operation by removing the appropriate tine(s) from the stop-cam level. In 1-cycle operation, the stop cam in row "6" is removed. This coding yields a maximum of 20 rows which are available for coding different characters into the answer-back drum. There are actually 21 rows on the answer-back drum, but only 20 rows can be used for coding since one row is suppressed. The number of rows available for message coding is summarized below for 1-, 2-, or 3-cycle operation:

<u>Cycle Operation</u>	<u>Actual Rows</u>	<u>Available Rows</u>
1	21	20
2	10(11)*	9(10)*
3	7	6

\* Alternately, one then the other.

When multiple-cycle operation is employed, the answer-back sequence must be coded in each segment of the answer-back drum so that the same message will be transmitted each time the answer-back mechanism is initiated.

(b) Character Suppression: Quite often, due to message length, messages coded into the answer-back drum do not require the use of every available row for coding. Un-

needed rows are eliminated from the message transmission by removing the unneeded character suppression tine(s). The answer-back drum will stop through its complete cycle, but the transmission of the coded characters from the unneeded rows will be shunted from the signal line.

Note: The character-suppression tine in the last row of a cycle should not be removed on 33 typing units used in systems where a response to each answer-back actuation signal must always be obtained. If the tine is removed, the answer-back mechanism will not respond to consecutive answer-back actuation signals. This is due to the operating characteristics of the typing unit which, when the character-suppression tine in the last row of a cycle is removed, leaves the answer-back blocking panel blocking at the end of the answer-back drum cycle of operation. The answer-back blocking pawl will remain blocking until after another character is received through the selector mechanism. The subsequently received character causes the function mechanism to reset the answer-back blocking pawl to its unblocking position. After being reset and upon receipt of an answer-back actuation signal, the answer-back mechanism will be triggered. Hence, with the character-suppression tine removed from the last row of an answer-back cycle, typing unit answer-back mechanisms will only respond to every other answer-back actuation signal unless an intervening character is received through the selector mechanism.

33 TYPING UNIT  
 LUBRICATION

CONTENTS	PAGE	CONTENTS	PAGE
1. GENERAL . . . . .	1	Stripper drive lever . . . . .	9
2. BASIC UNITS . . . . .	3	Trip lever . . . . .	8
COMMON MECHANISMS . . . . .	3	Trip shaft . . . . .	4
Armature . . . . .	18	Typewheel mechanism . . . . .	16
Automatic codebar . . . . .	9	FRICITION FEED MECHANISMS . . . . .	20
Blocking levers . . . . .	18	Line feed mechanism . . . . .	21
Carriage area . . . . .	13	Paper feed area . . . . .	20
Carriage rear rail . . . . .	17	Platen . . . . .	20
Carriage return and spacing levers . .	12	SPROCKET FEED MECHANISMS . . . . .	21
Codebars . . . . .	9	Cam, pulley, and gear combination . .	23
Codebar clutch . . . . .	4	Form-out mechanism . . . . .	24
Dashpot . . . . .	14	Line feed clutch . . . . .	25
Disc and brushes . . . . .	7	Paper feed area . . . . .	21
Distributor area . . . . .	6	Platen mechanism . . . . .	22
Drive arm . . . . .	15	Platen drive area . . . . .	23
Drive mechanism . . . . .	11	3. VARIATIONS TO BASIC UNITS . . . . .	25
Function area . . . . .	8	Answer-back area . . . . .	25
Function clutch . . . . .	3	Answer-back mechanism . . . . .	26
Function levers . . . . .	9	Trip magnet . . . . .	26
Function rocker shaft . . . . .	6	1. GENERAL	
Function shaft area . . . . .	5	1.01 This section provides lubrication re-	
Intermediate gears . . . . .	5	quirements for the 33 typing unit. It is	
Latchlever . . . . .	7	reissued to provide exclusive eight level typing	
Latchlever and trip lever . . . . .	19	unit coverage and present a new order of lubri-	
Main shaft area . . . . .	3	cation. Since this is a general revision, mar-	
Motor area . . . . .	5	ginal arrows used to indicate changes are	
Print hammer . . . . .	15	omitted.	
Pushlevers and stripper bail . . . . .	18	1.02 The general lubrication areas are illus-	
Reset arm . . . . .	15	trated by photographs. The specific	
Reset bail . . . . .	10	points to receive lubricant are indicated on line	
Ribbon guide spring . . . . .	17	drawings with appropriate textual instructions.	
Ribbon mechanism . . . . .	16	Line drawings and textual instructions follow	
Rocker and pawls . . . . .	10	each photograph and are keyed to the photograph	
Selector area . . . . .	17	by paragraph numbers.	
Selector clutch . . . . .	19		
Selector levers . . . . .	19		
Slides . . . . .	14		
Slide guideplates . . . . .	14		
Spacing area . . . . .	11		
Space bellcrank . . . . .	11		
Spacing mechanism - 1 . . . . .	12		
Spacing mechanism - 2 . . . . .	13		
Stop bail . . . . .	7		

SECTION 574-122-701TC

1.03 Thoroughly lubricate the typing unit, but avoid overlubrication that might permit the lubricant to drip or be thrown onto adjacent parts. Saturate all felt washers and oilers with oil, and apply oil to each end of all bearings.

1.04 Lubricate the typing unit before placing it into service or prior to storage. After a short period of service, relubricate it to make sure no areas have been missed. Thereafter, lubricate the typing unit at regular intervals as indicated below:

<u>Operating Speed</u> (Words per Minute)	<u>Lubrication Interval</u>
100	500 hrs* or 6 mo.**

\*Station set operating hours

\*\*Whichever comes first

1.05 On occasion when the printer is disassembled, apply a coat of thoroughly mixed 50 percent KS7470 oil and 50 percent KS7471 grease at places indicated below.

- Selector Cam Surfaces (2.44)
- Spacing Gear Teeth (2.24)
- Codebar Pivot Shaft (2.18 and 2.19)
- Eccentric Cams (2.02 and 2.04)
- Stop Bail Adjusting Tab (2.12)
- Platen Shaft Bearings-Sprocket Feed Units only (2.49)

Note 1: On occasion when the clutch is disassembled, lubricate the Internal Clutch Assemblies (2.02, 2.04, 2.10, 2.44, and 2.53 on Form Feed Mechanisms only) as follows: Apply a thin coat of KS7471 grease at the loops of the clutch shoe lever spring, and lubricate the internal mechanism of the clutch with KS7470 oil.

Note 2: At regular lubrication intervals lubricate the clutch mechanism with KS-7470 oil only.

1.06 The textual instructions that accompany the line drawings consist of abbreviated directions, specific lubrication points, and parts affected. The meanings of the abbreviated directions (symbols) follow:

<u>Symbol</u>	<u>Meaning</u>
D	Keep dry — no lubricant permitted.
G	Apply thin coat of grease (KS7471).
O	Oil (KS7470).

1.07 References to left, right, front, or rear, etc, consider the typing unit to be viewed from a position where the carriage area faces up and the selector area is located to the viewer's left.

**CAUTION: DO NOT USE ALCOHOL, MINERAL SPIRITS, OR OTHER SOLVENTS TO CLEAN PLASTIC PARTS OR PARTS WITH PROTECTIVE - DECORATIVE FINISHES. NORMALLY, A SOFT, DRY CLOTH SHOULD BE USED TO REMOVE DUST, OIL, GREASE, OR OTHERWISE CLEAN PARTS OR SUBASSEMBLIES. IF NECESSARY, A SOFT CLOTH DAMPENED WITH SOAP OR MILD DETERGENT MAY BE USED. AFTERWARDS, RINSE EACH CLEANED PART OR SUBASSEMBLY WITH SOFT, DAMP CLOTH AND BUFF WITH A SOFT, DRY CLOTH.**

1.08 Tools and materials needed for teletypewriter lubrication are listed in Section 570-005-800TC.

1.09 For disassembly and reassembly information, refer to Section 574-122-702TC.

**CAUTION: ALL ELECTRICAL POWER MUST BE REMOVED FROM UNIT BEFORE LUBRICATING OR REMOVING COMPONENTS FOR LUBRICATION.**

2. BASIC UNITS

COMMON MECHANISMS

2.01 Main Shaft Area

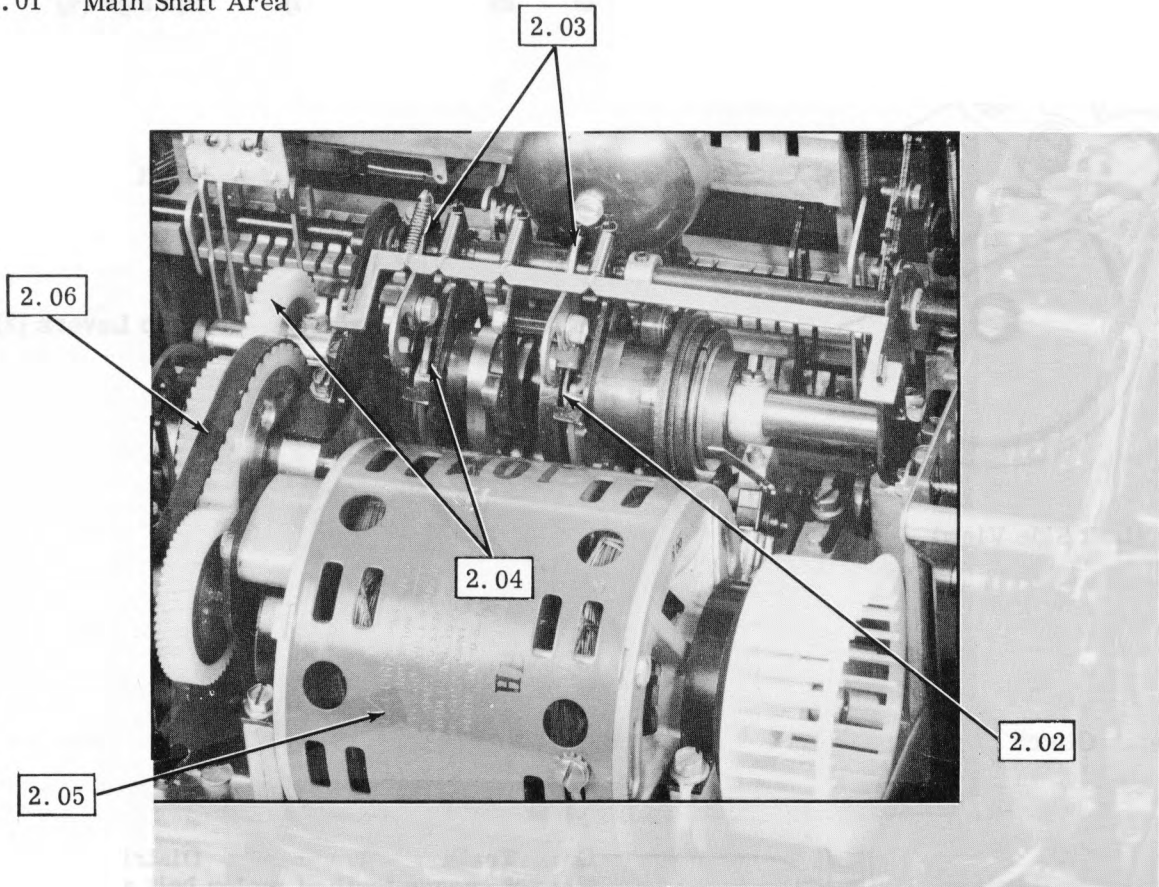

(Rear View)

2.02 Function Clutch

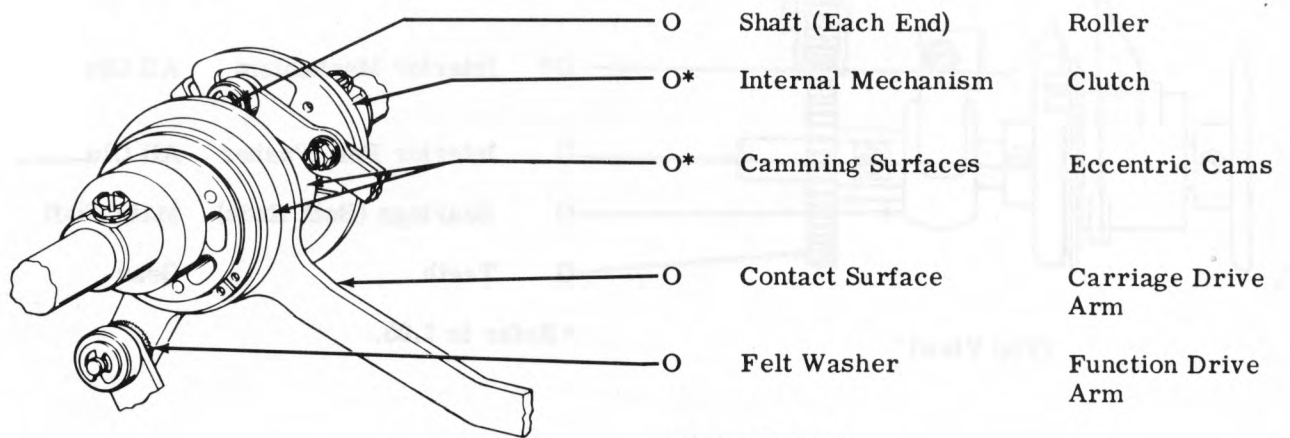

\*Refer to 1.05.

(Left Front View)

SECTION 574-122-701TC

2.03 Trip Shaft

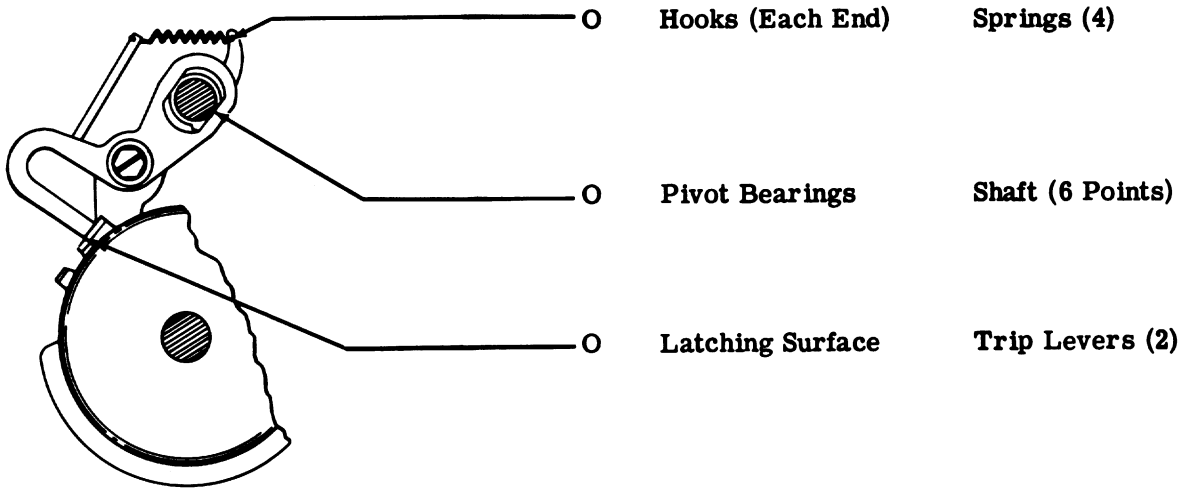

(Left Side View)

- |   |                  |                  |
|---|------------------|------------------|
| O | Hooks (Each End) | Springs (4)      |
| O | Pivot Bearings   | Shaft (6 Points) |
| O | Latching Surface | Trip Levers (2)  |

2.04 Codebar Clutch

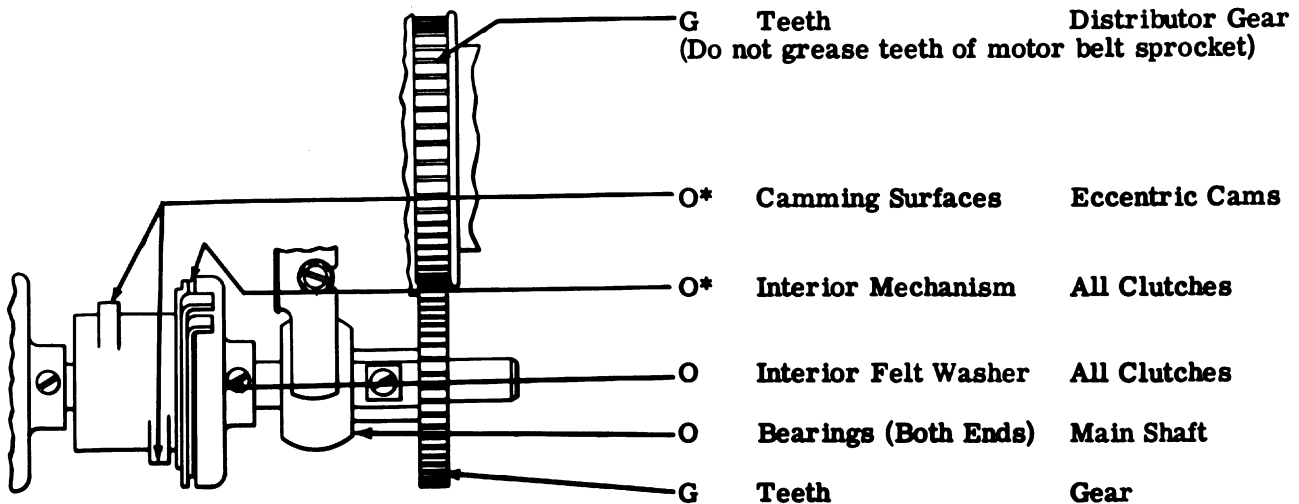

(Top View)

- |  |                      |                  |
|--|----------------------|------------------|
| G  | Teeth                | Distributor Gear |
| (Do not grease teeth of motor belt sprocket) |                      |                  |
| O*   | Camming Surfaces     | Eccentric Cams   |
| O*   | Interior Mechanism   | All Clutches     |
| O  | Interior Felt Washer | All Clutches     |
| O  | Bearings (Both Ends) | Main Shaft       |
| G  | Teeth                | Gear             |

\* Refer to 1.05.

2.05 Motor Area

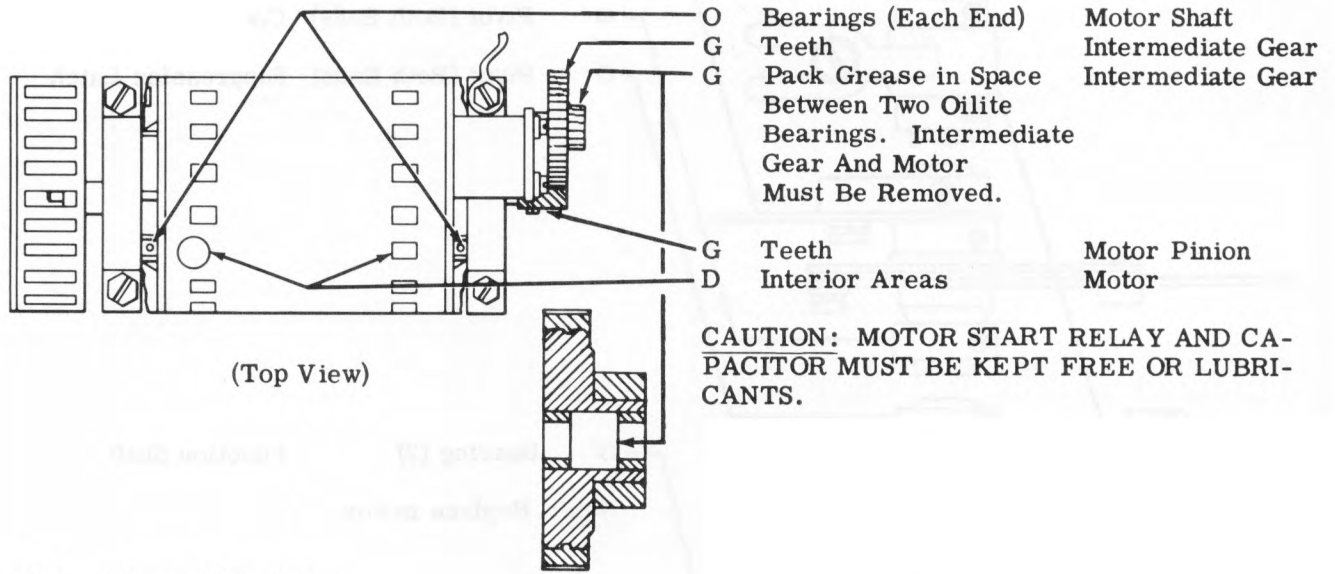

2.06 Intermediate Gears

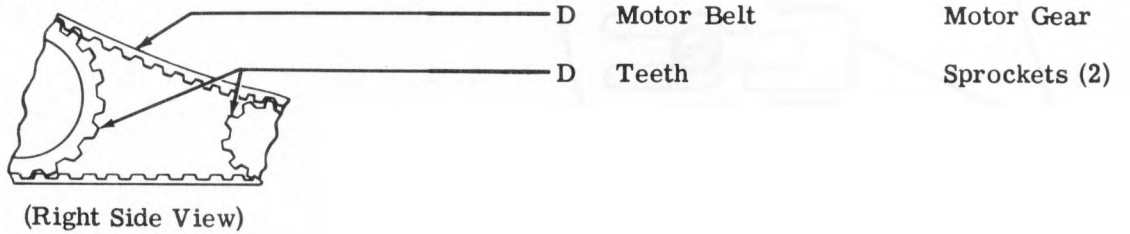

2.07 Function Shaft Area

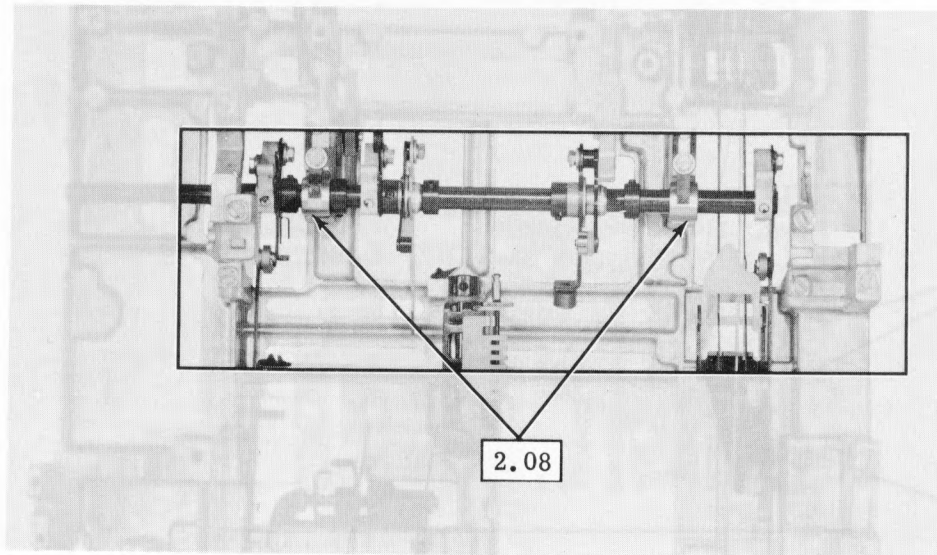

(Top View)

(Typing unit disassembled for illustration only.)



SECTION 574-122-701TC

2.08 Function Rocker Shaft

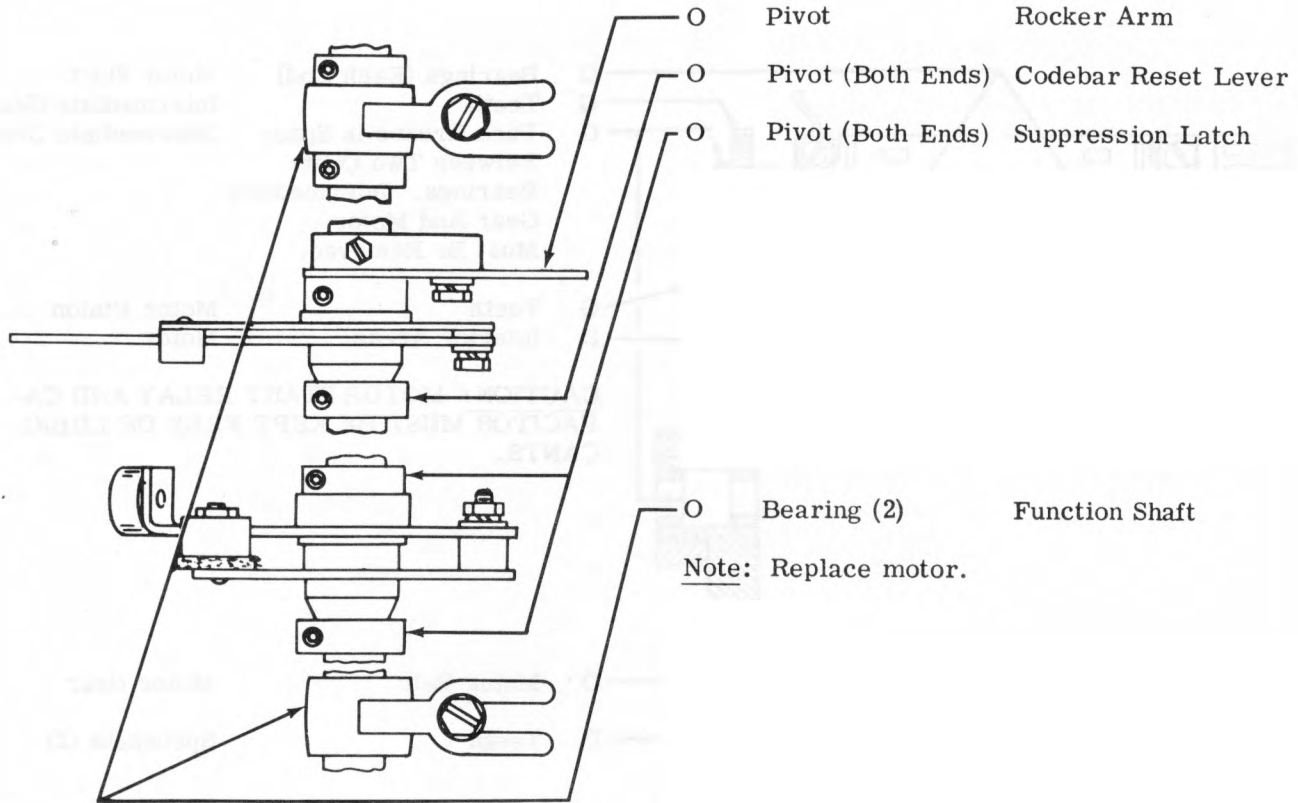

2.09 Distributor Area

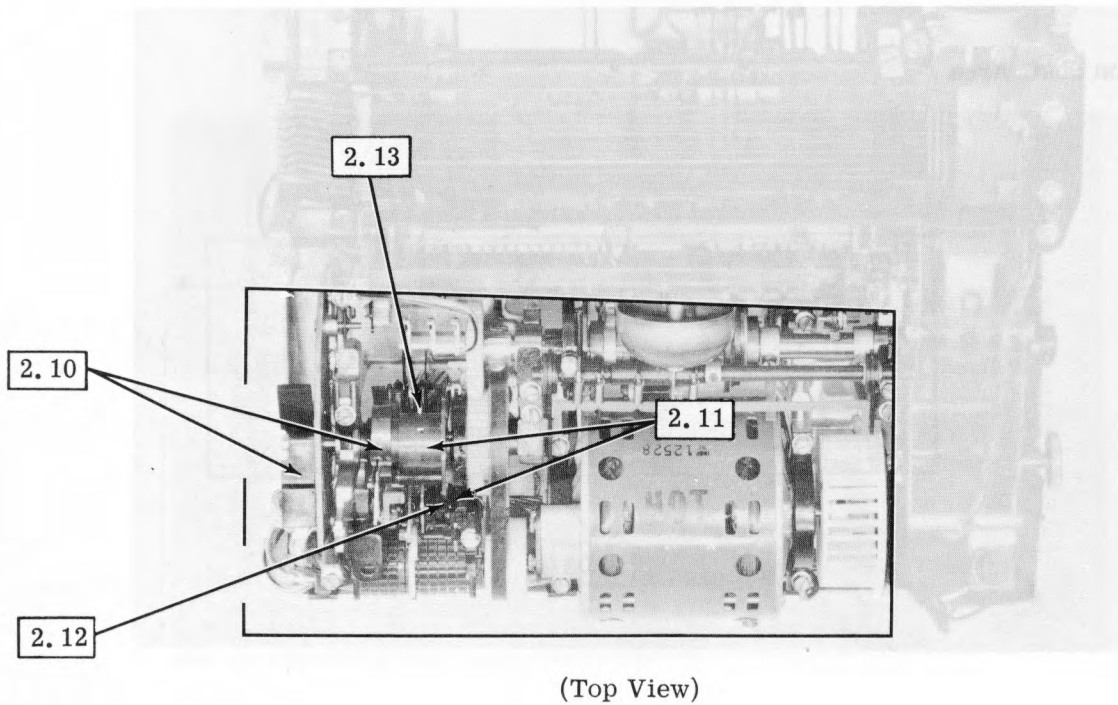

2.10 Disc and Brushes

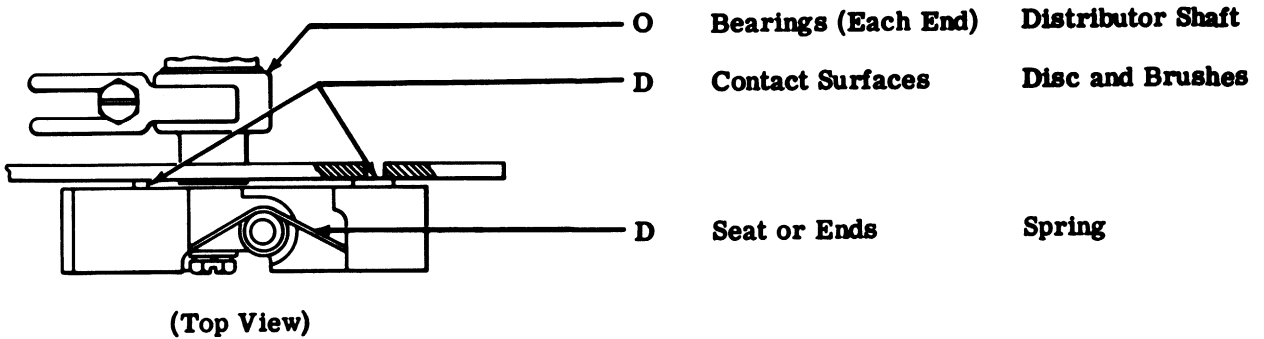

2.11 Stop Bail

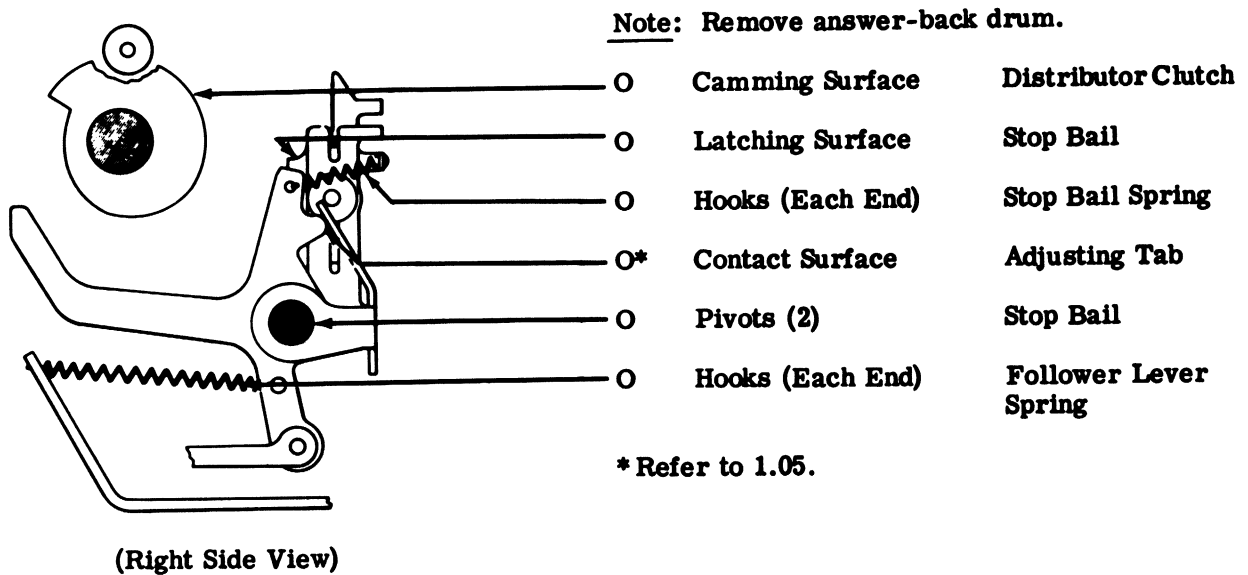

2.12 Latchlever

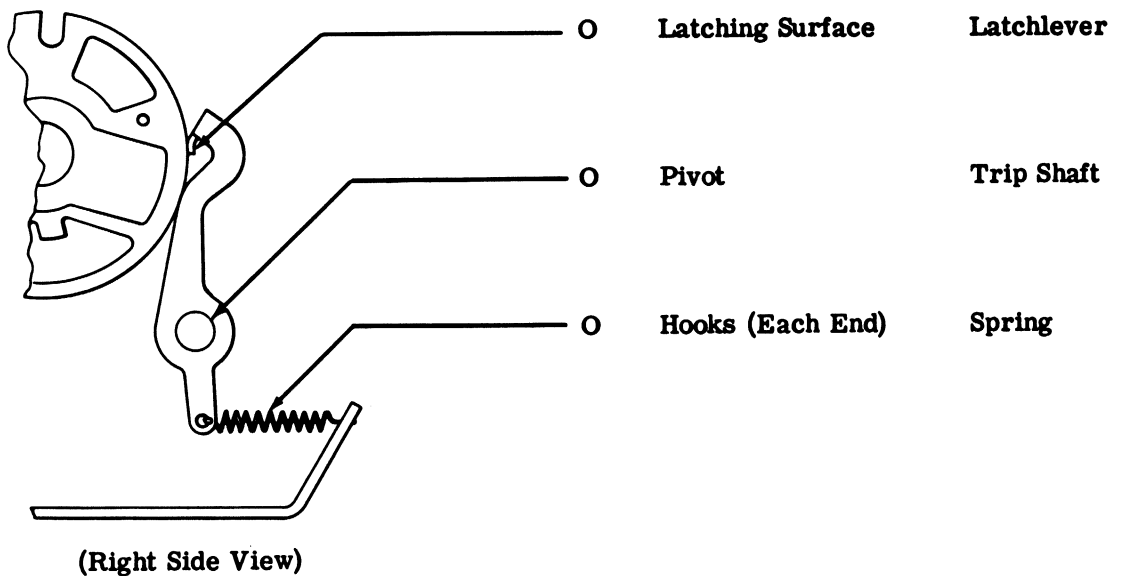

2.13 Trip Lever

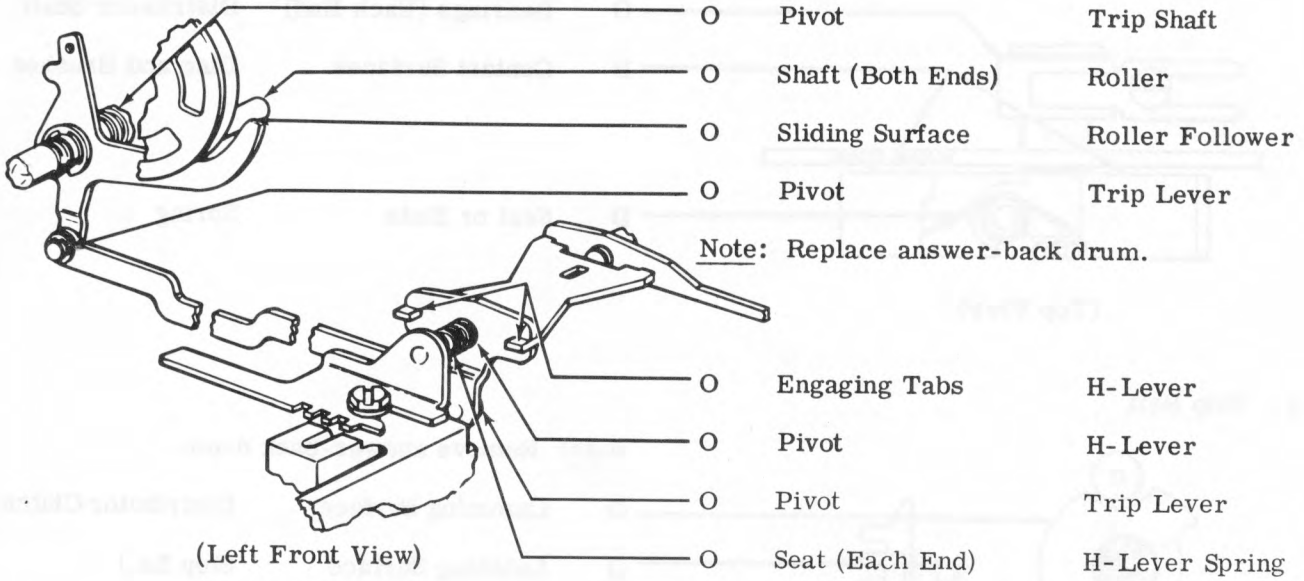

2.14 Function Area

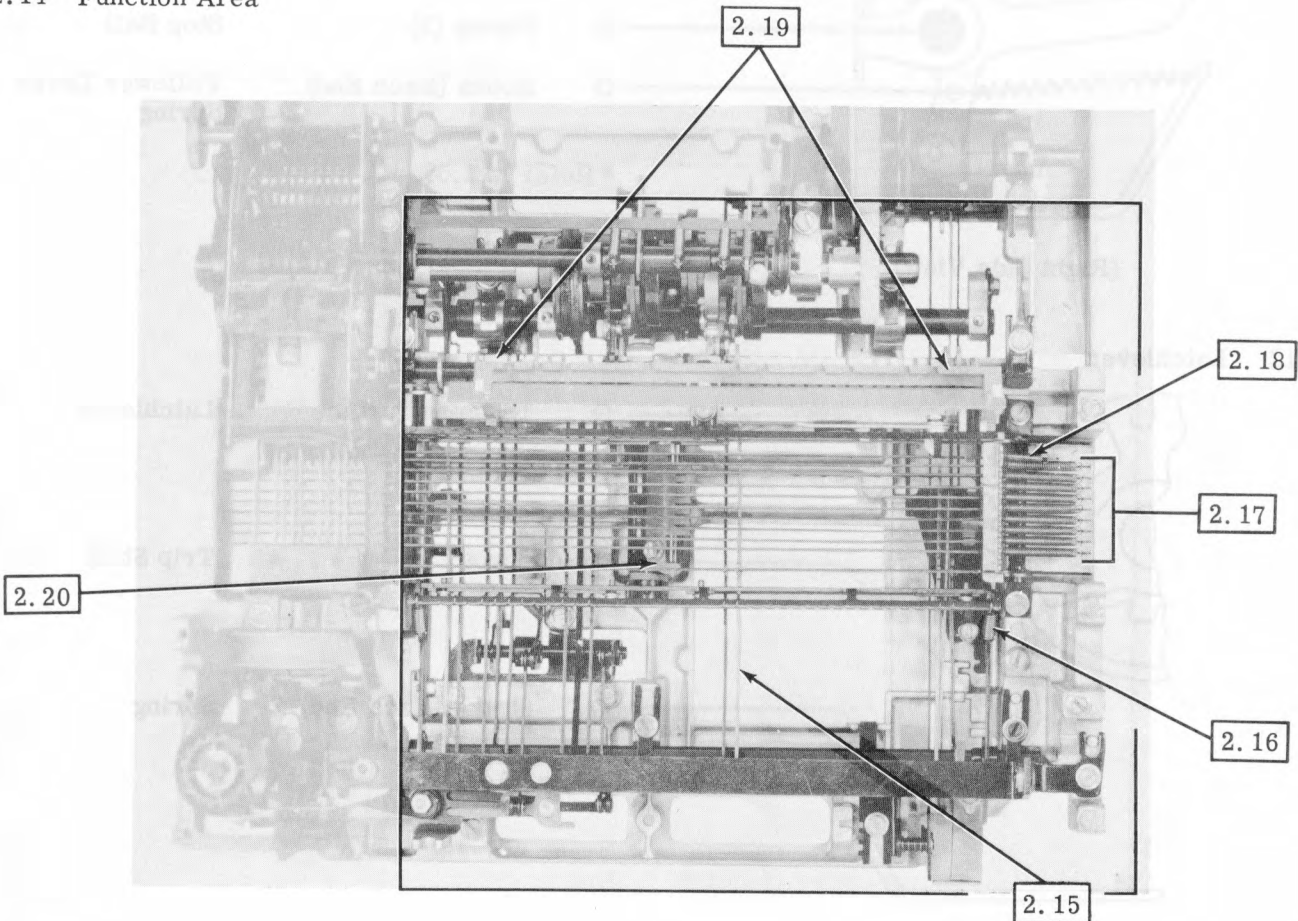

**2.15 Function Levers**

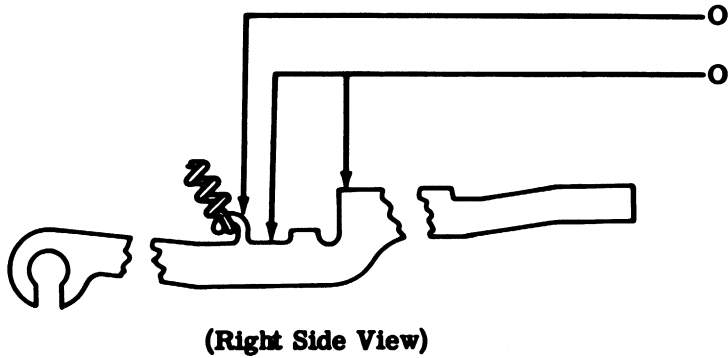

- O Hooks (Each End)
- O Engaging Surfaces
- O Springs
- O Function Levers

**2.16 Stripper Drive Lever**

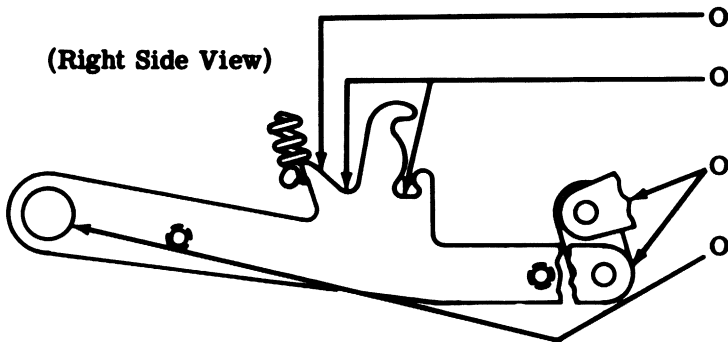

- O Hooks (Each End)
- O Engaging Surfaces
- O Pivots
- O Felt Washers (2) (Each End of Shaft)
- O Springs
- O Stripper Drive Lever
- O Stripper Drive Link
- O Front Function Shaft

**2.17 Codebars**

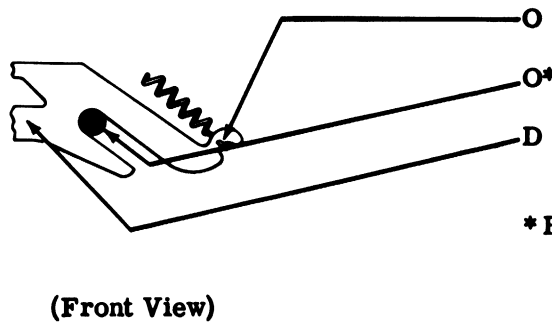

- O Hooks (Each End)
- O\* Pivots
- O Area Between Codebars
- O Springs
- O Shaft

\* Refer to 1.05.

**2.18 Automatic Codebar**

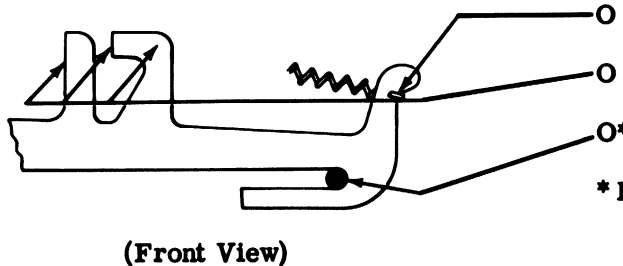

- O Hooks (Each End)
- O Blocking Contact
- O\* Pivot
- O Spring
- O Tab (1 of 3)
- O Shaft

\* Refer to 1.05.

2.19 Rocker and Pawls

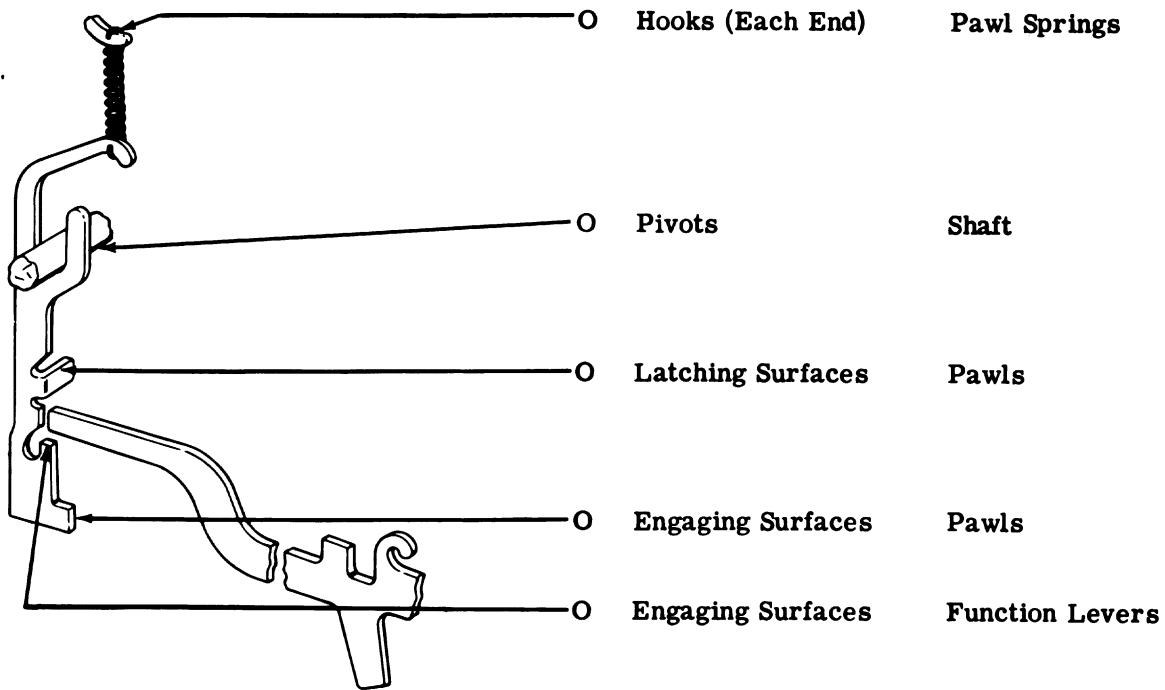

(Left Front View)

2.20 Reset Bail

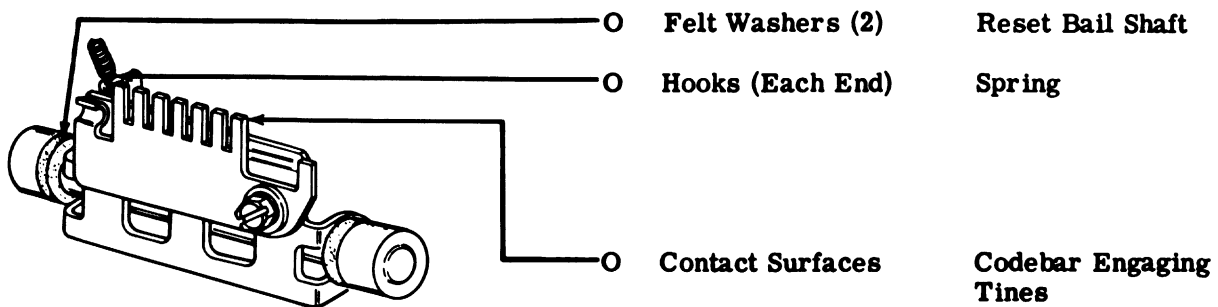

(Left Front View)

2.21 Spacing Area

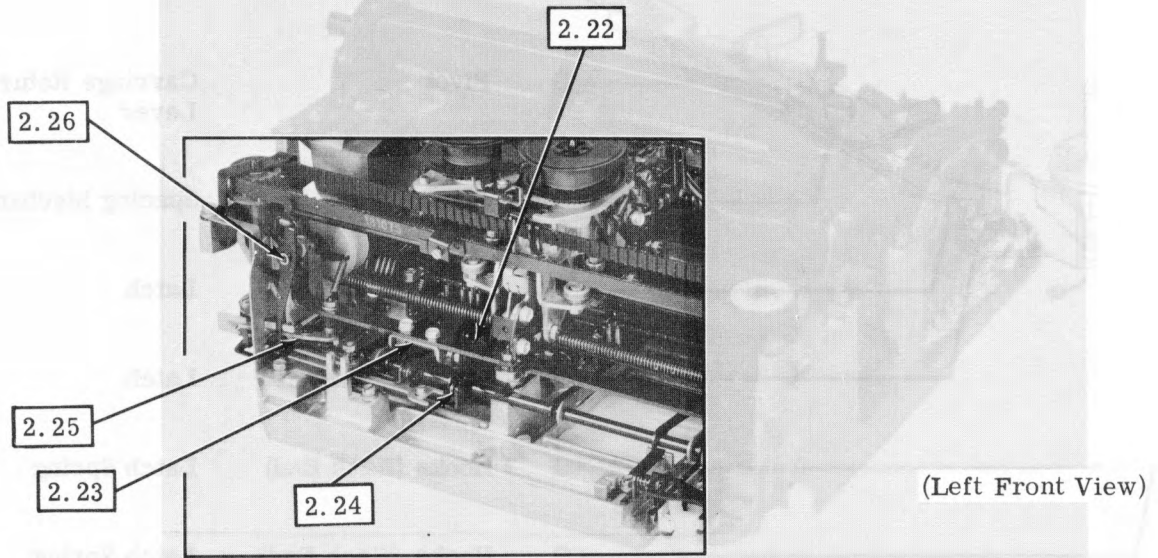

2.22 Space Bellcrank

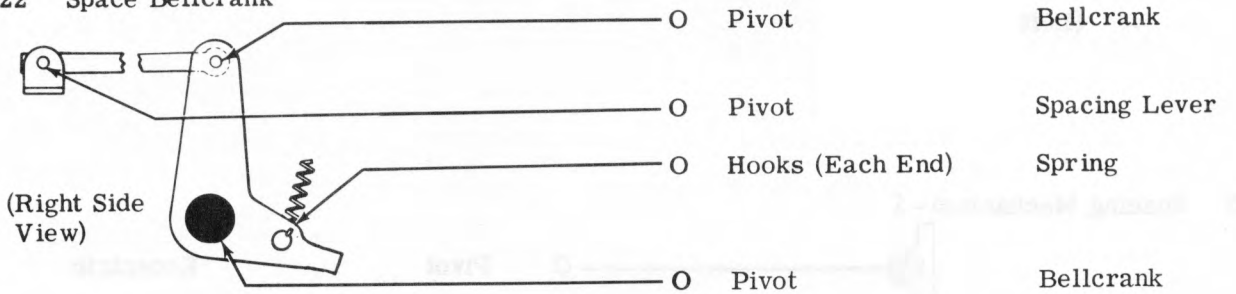

2.23 Drive Mechanism

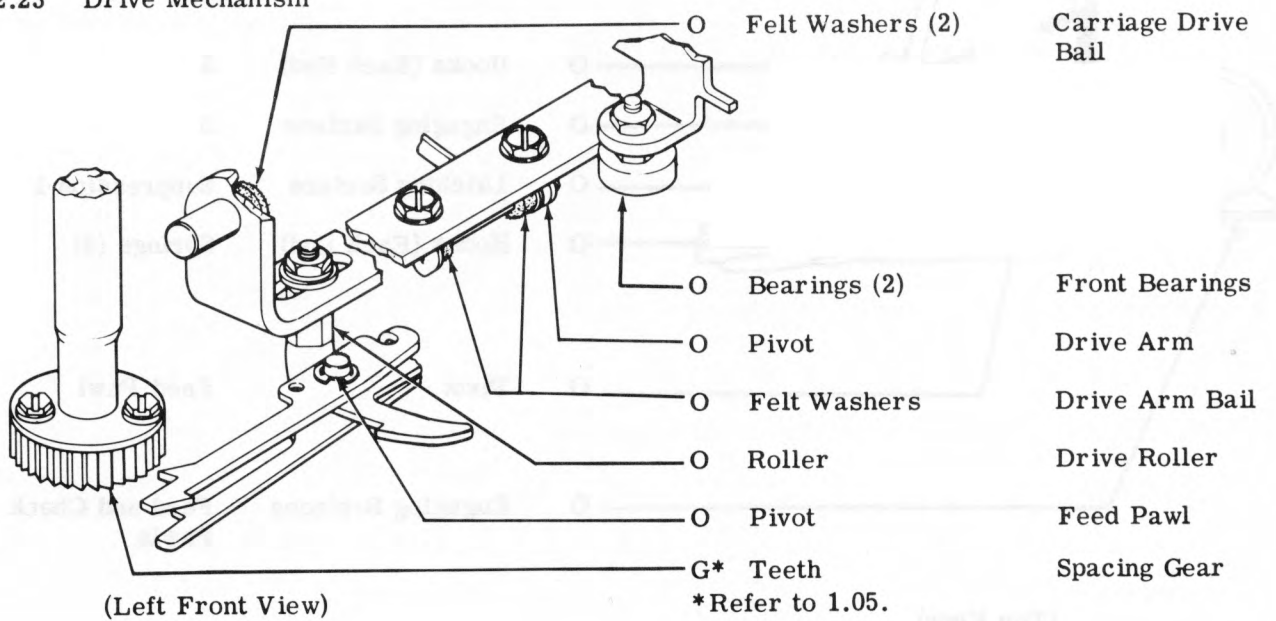

2.24 Carriage Return and Spacing Levers

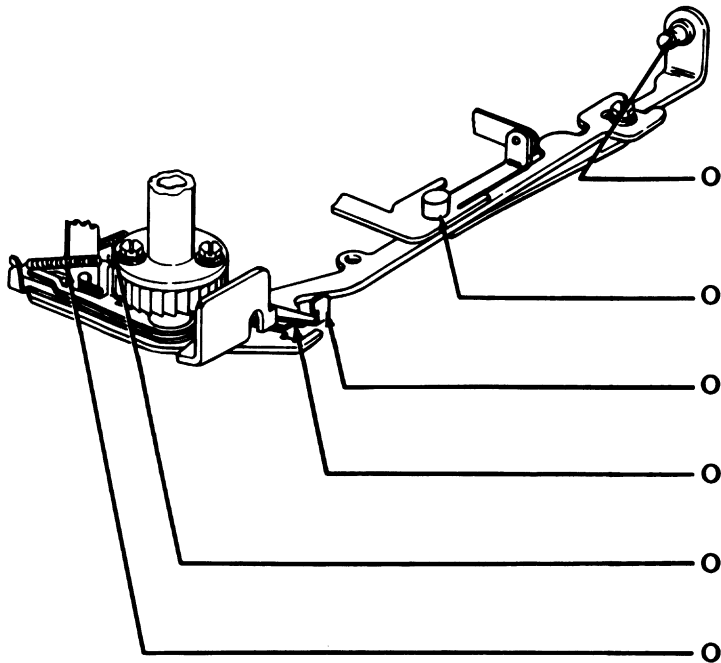

- |                  |                       |
|------------------|-----------------------|
| Pivot            | Carriage Return Lever |
| Pivot            | Spacing Mechanism     |
| Engaging Surface | Latch                 |
| Latching Surface | Latch                 |
| Hooks (Each End) | Latch Spring          |
| Hooks (Each End) | Latch Spring          |

(Left Front View)

2.25 Spacing Mechanism - 1

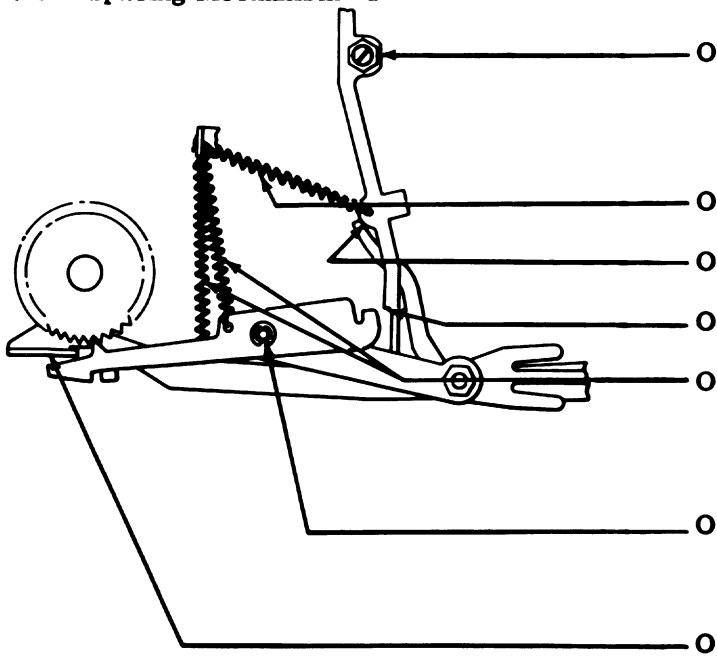

- |                   |                      |
|-------------------|----------------------|
| Pivot             | Eccentric            |
| Hooks (Each End)  | Spring               |
| Engaging Surface  | Spacing Lever        |
| Latching Surface  | Suppression Lever    |
| Hooks (Each End)  | Springs (3)          |
| Pivot             | Feed Pawl            |
| Engaging Surfaces | Feed and Check Pawls |

(Top View)

2.26 Spacing Mechanism - 2

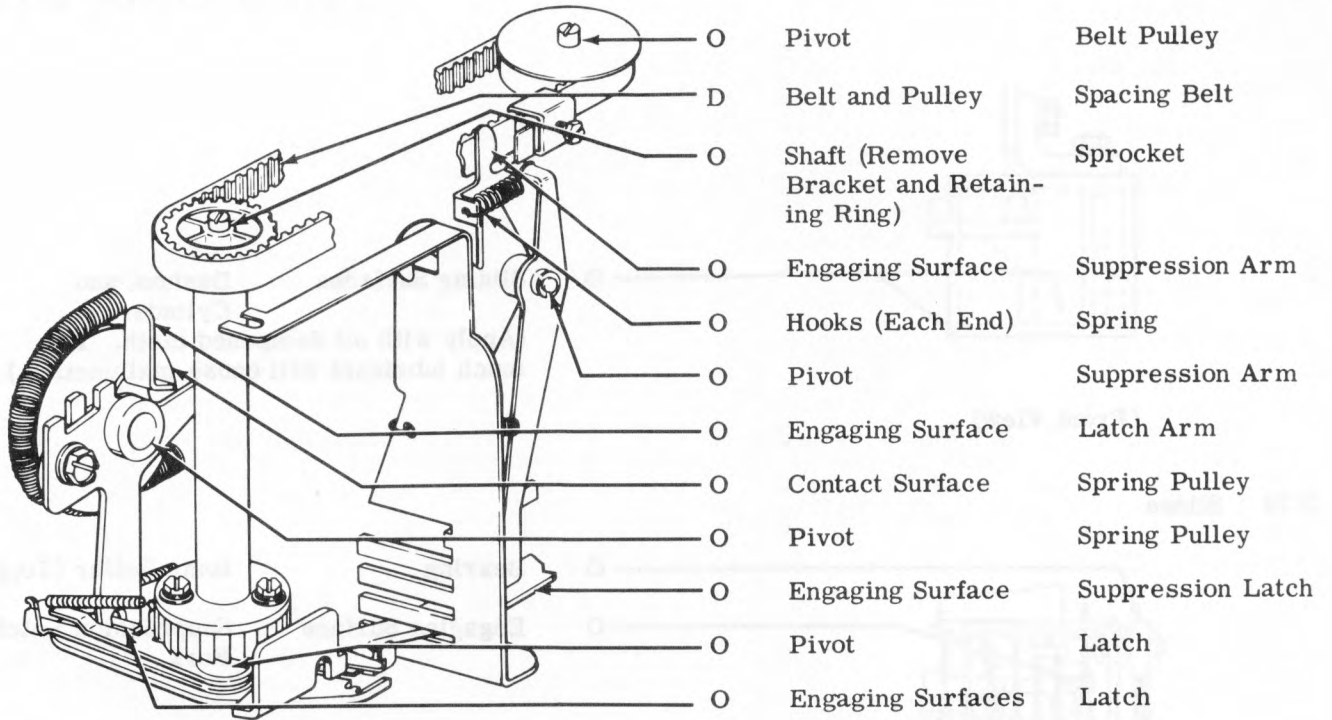

(Left Front View)

2.27 Carriage Area

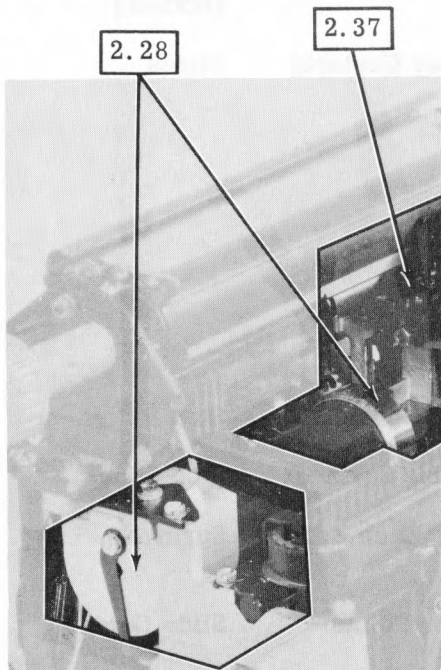

(Left Front View)

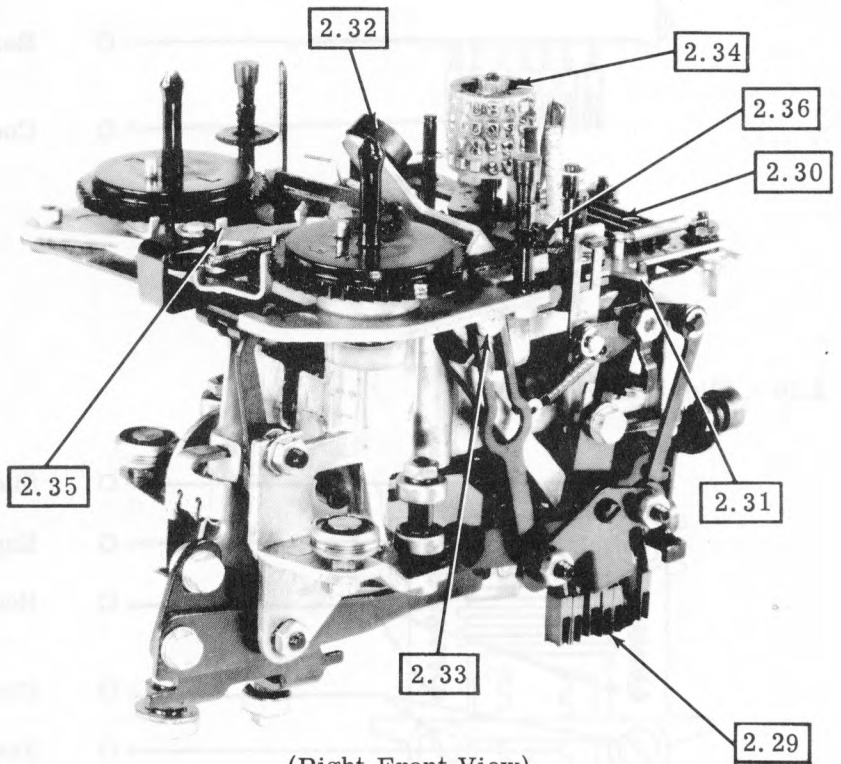

(Right Front View)

Note: Remove ribbon mechanism and carriage return spring before lubricating. For instructions, see the appropriate disassembly and reassembly section.



SECTION 574-122-701TC

2.28 Dashpot

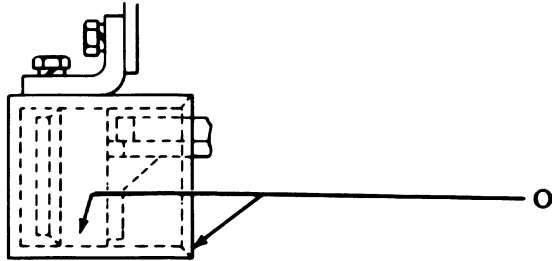

(Front View)

Sliding Surfaces      Dashpot and  
Cylinder  
(Apply with oil dampened cloth. Too  
much lubricant will cause malfunction.)

2.29 Slides

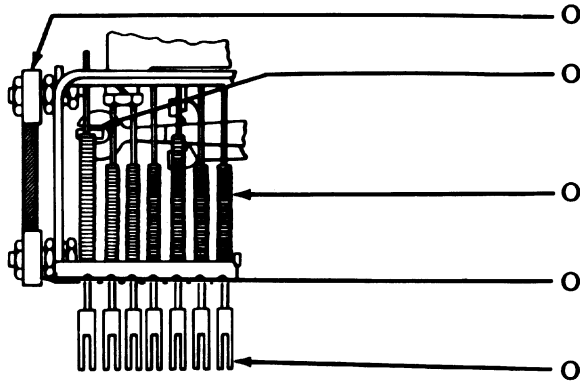

(Left Side View)

Bearing	Rear Roller (Top)
Engaging Surface	Suppression Latch Fork
Seats (Each End)	Slide Guide Springs
Bearing	Rear Roller (Bottom)
Codebar Contacts	Slides

2.30 Slide Guideplates

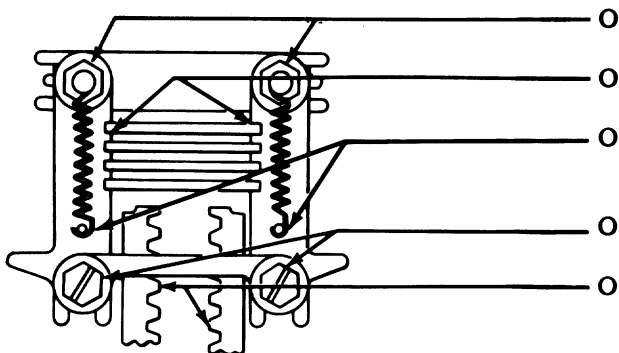

(Top View)

Sliding Contacts	Stop Plate
Engaging Surfaces	Stop Slides
Hooks (Each End)	Springs
Contact Points	Slide Guides
Teeth	Pinion Racks

2.31 Drive Arm

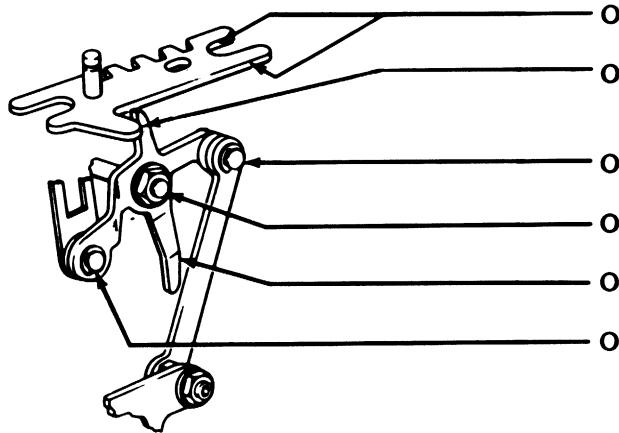

(Right Side View)

- O Contact Surface Plate
- O Contact Surfaces Plate and Drive Arm
- O Pivot Drive Arm
- O Pivot Drive Arm
- O Contact Surface Drive Arm
- O Pivot Link

2.32 Print Hammer

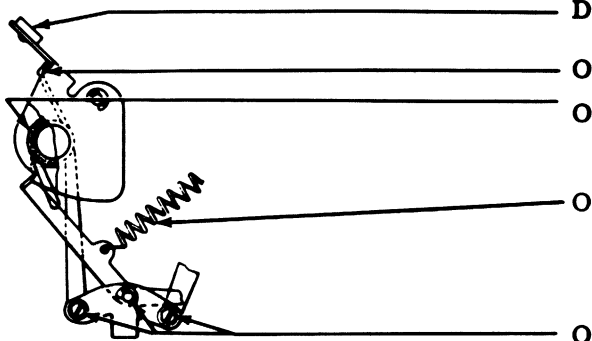

(Right Side View)

- D Surface Print Hammer
- O Ends (2) Torsion Spring
- O Pivots (2) Spring Shaft
- O Hooks (Each End) Spring
- O Bearings (3) Drive Bail

2.33 Reset Arm

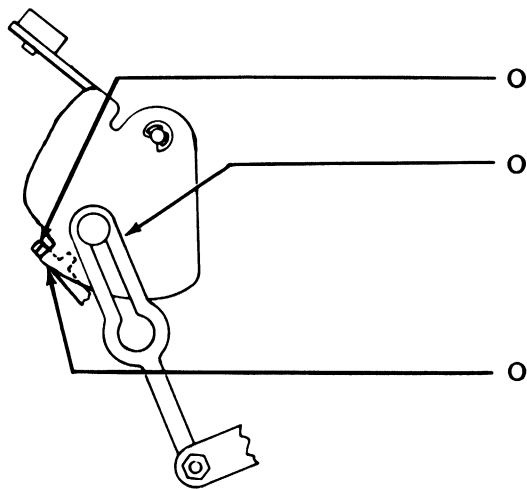

(Right Side View)

- O Latching Surface Trip Lever
- O Sliding Contacts Reset Arm
- O Camming Surface Print Hammer Bail

2.34 Typewheel Mechanism

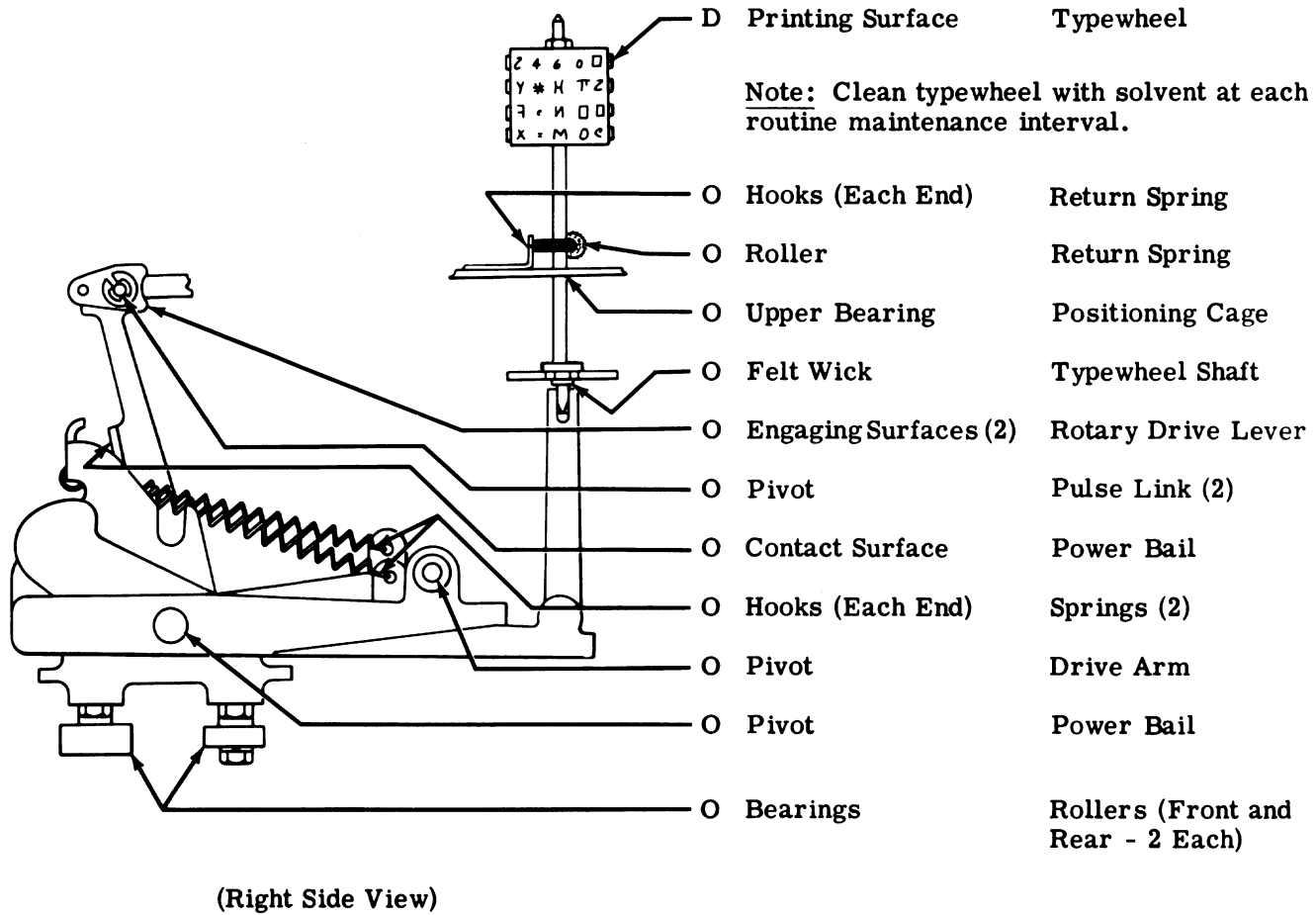

2.35 Ribbon Mechanism

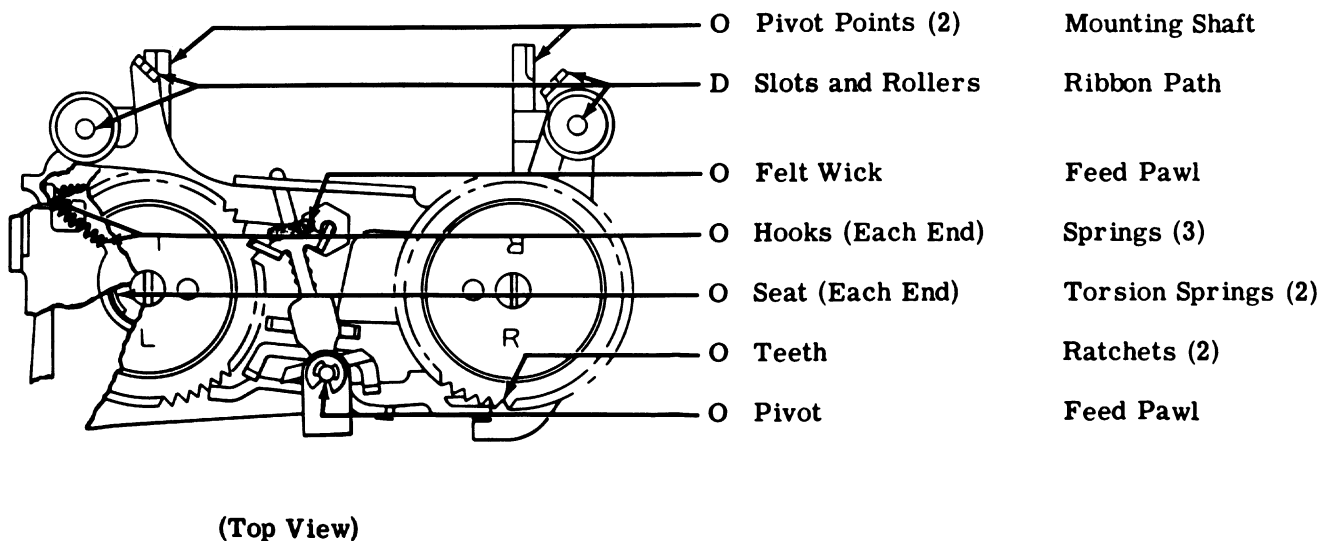

2.36 Ribbon Guide Spring

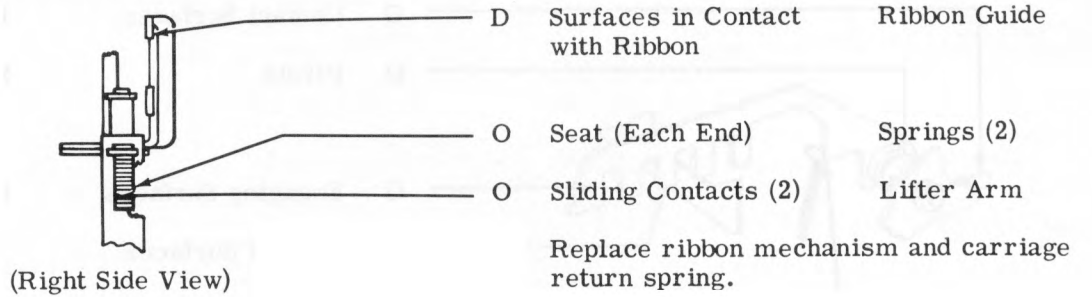

2.37 Carriage Rear Rail

Note: These lubrication instructions apply only to typing units equipped with a TP181304 latch.

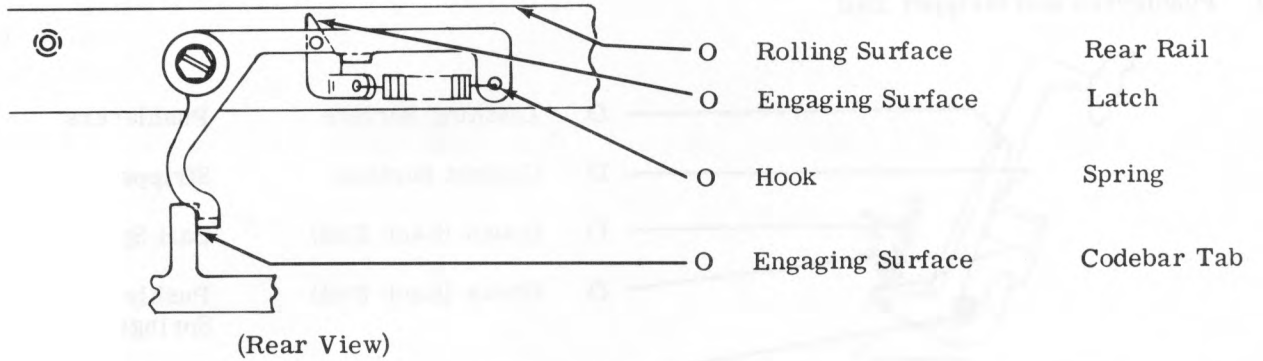

2.38 Selector Area

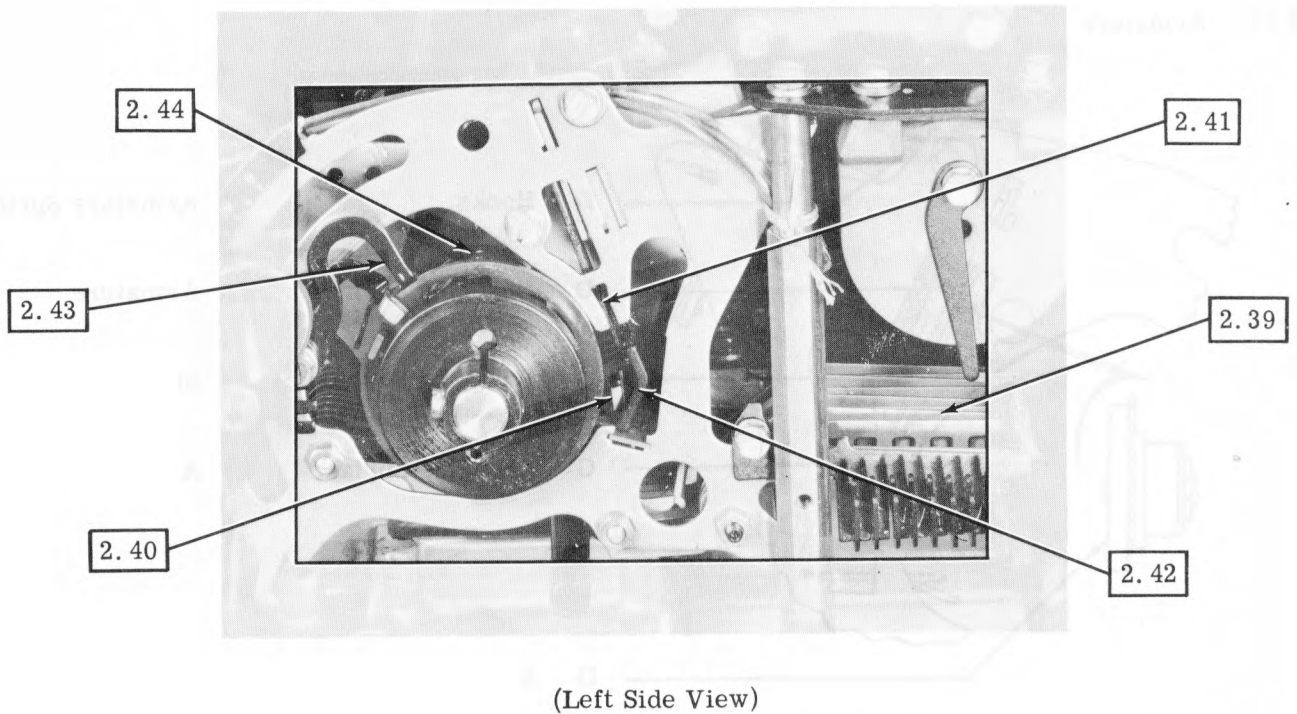

2.39 Blocking Levers

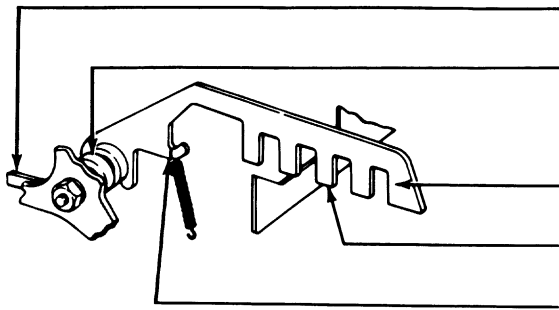

(Left Front View)

- O Contact Surfaces      Blocking Levers
- O Pivots                      Shaft
- O Engaging Surfaces      Codebar Slots
- O Contact Surfaces      Tines
- O Hooks                      Springs

2.40 Pushlevers and Stripper Bail

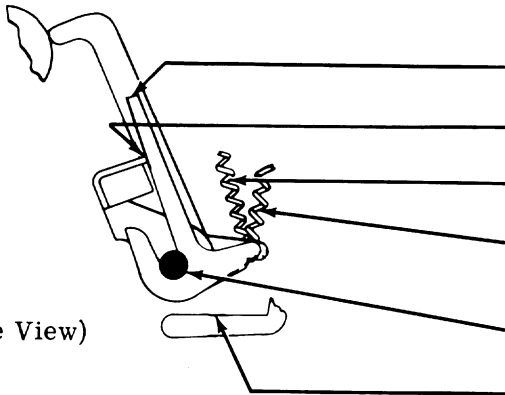

(Left Side View)

- O Latching Surface      Pushlevers
- O Contact Surface      Stripper Bail
- O Hooks (Each End)      Bail Spring
- O Hooks (Each End)      Pushlever Springs
- O Pivots                      Pushlevers
- O Contact Surfaces      Blocking Levers

2.41 Armature

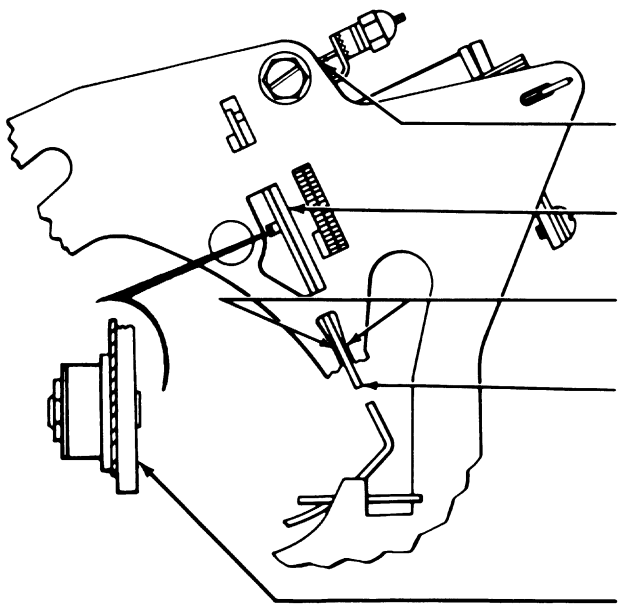

(Left Side View)

- D Hooks                      Armature Spring
- D Engaging Surfaces      Armature
- O Engaging Surfaces      Side Plates
- G Engaging Surface      Armature
- D Engaging Surface      Armature

**2.42 Selector Levers**

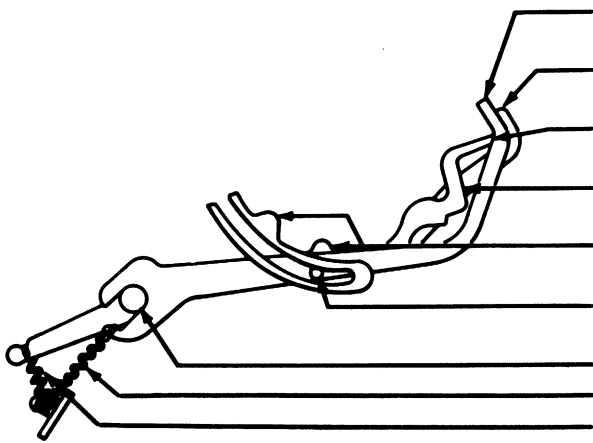

(Left Side View)

- O Tip Start Lever
- O Contact Surface Locklever
- O Contact Surface Selector Levers
- O Engaging Surface Selector Levers
- O Camming Surface Selector Levers
- O Sliding Contact Start Lever
- O Pivots Levers
- O Hooks (Each End) Start Lever Spring
- O Hooks (Each End) Spring (9)

**2.43 Latchlever and Trip Lever**

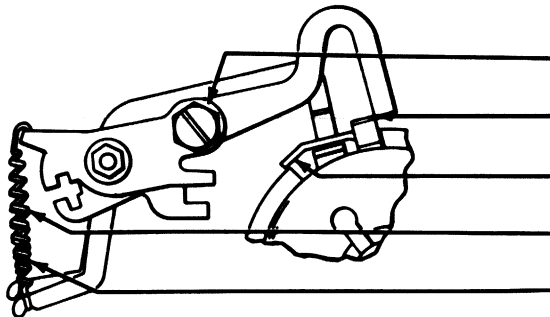

(Left Side View)

- O Pivots (2) Levers
- O Engaging Surface Trip Lever
- O Latching Surface Latchlever
- O Hooks (Each End) Trip Lever Spring
- O Hooks (Each End) Latchlever Spring

**2.44 Selector Clutch**

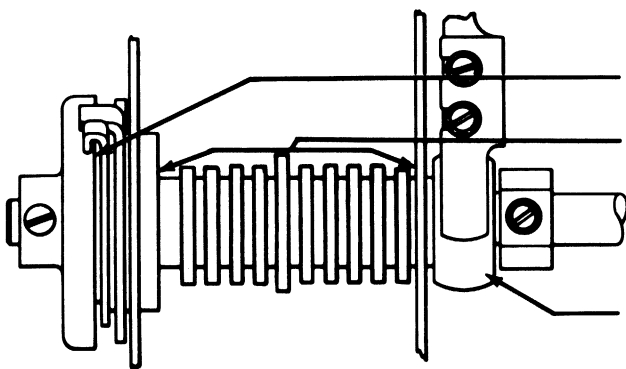

(Top View)

- O\* Internal Mechanism Selector Clutch
- O\* Camming Surface Selector Clutch
- O Bearing (Each End) Main Shaft

\*Refer to 1.05.

FRICION FEED MECHANISMS

2.45 Paper Feed Area

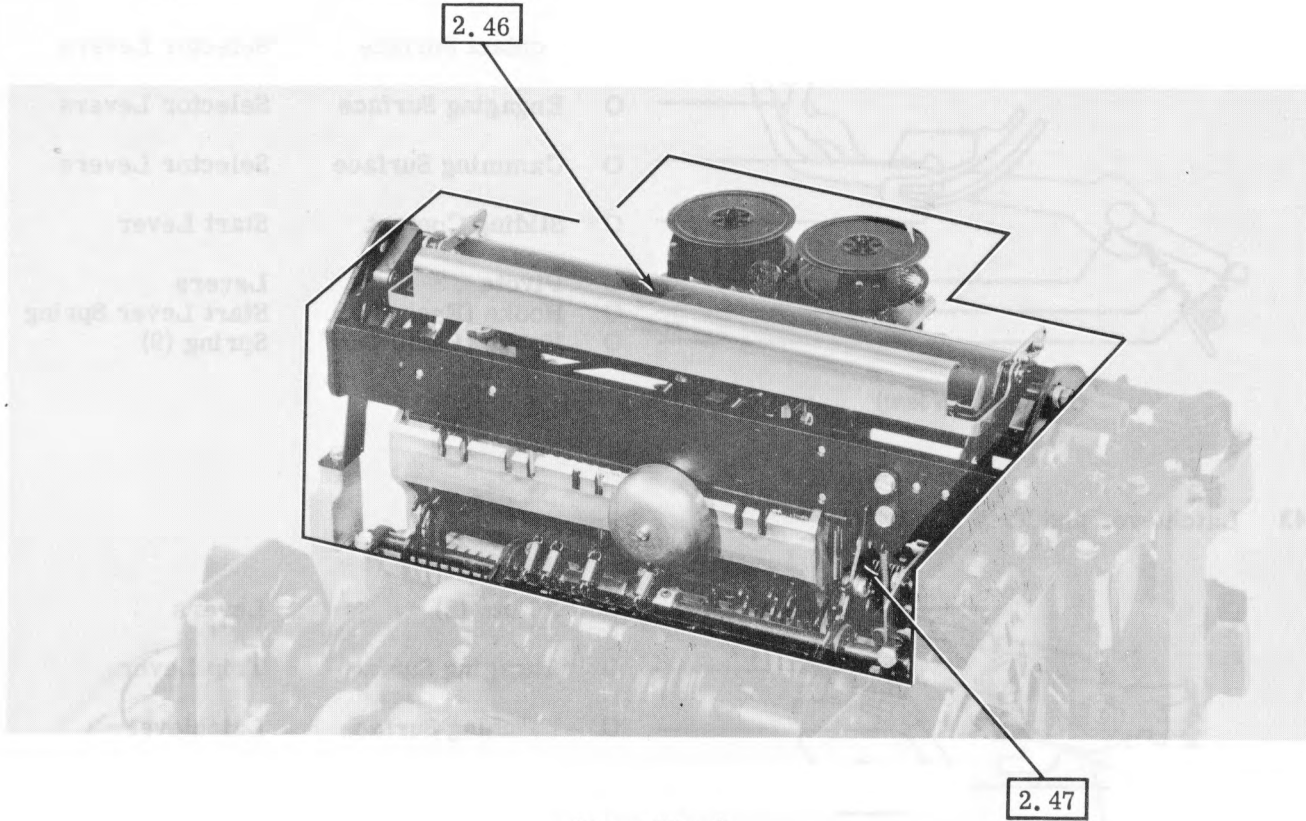

(Rear View)

2.46 Platen

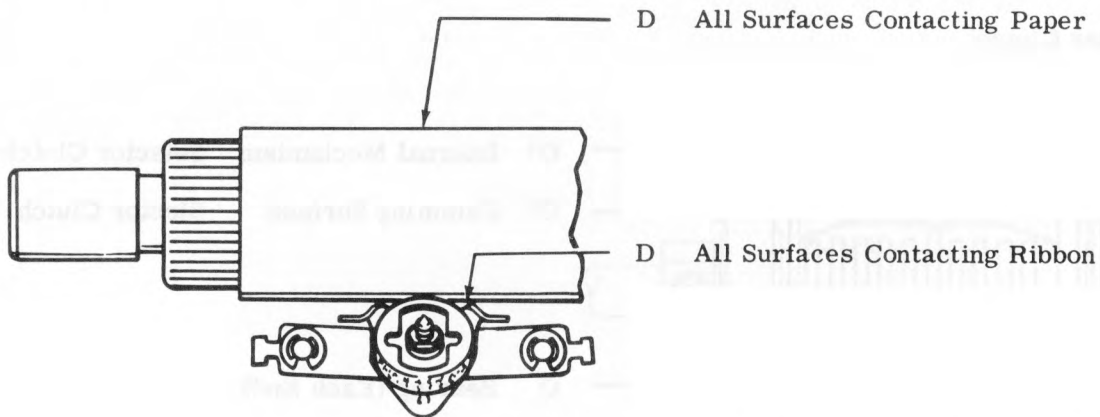

**CAUTION: DO NOT CLEAN PLATEN WITH SOLVENTS.**

2.47 Line Feed Mechanism

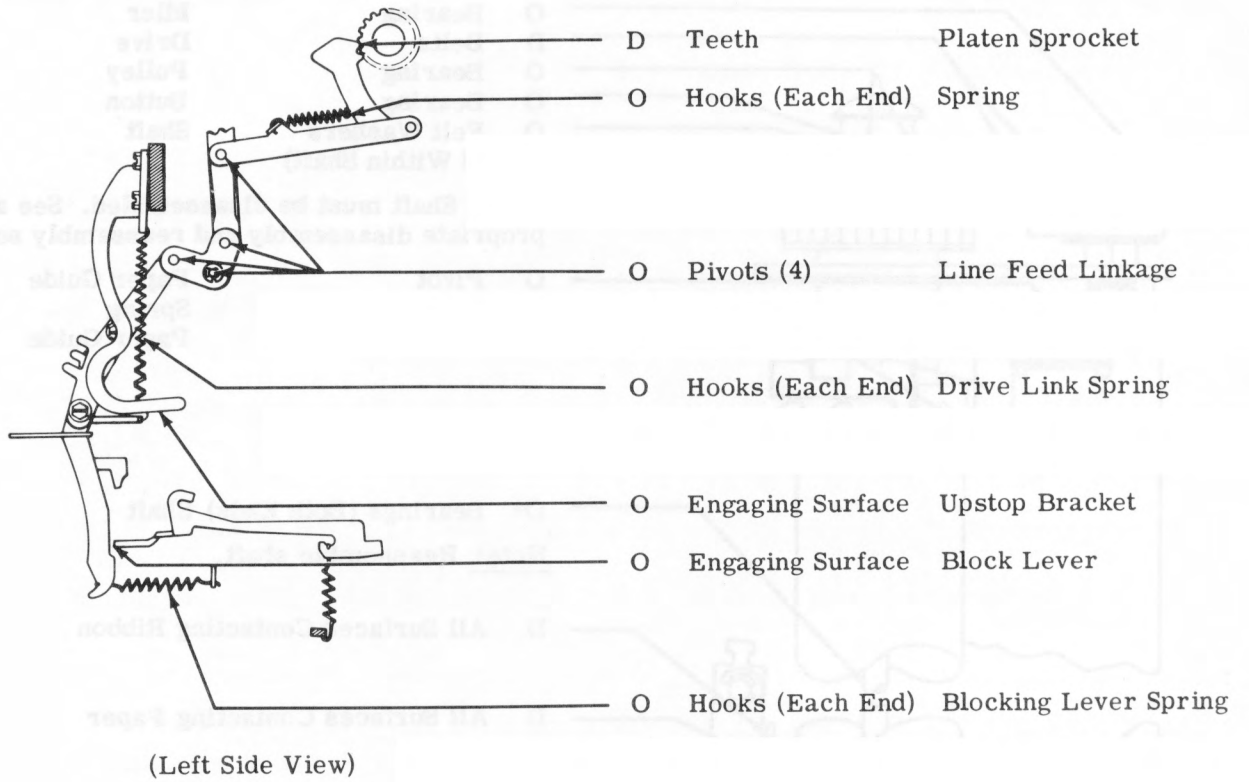

SPROCKET FEED MECHANISMS

2.48 Paper Feed Area

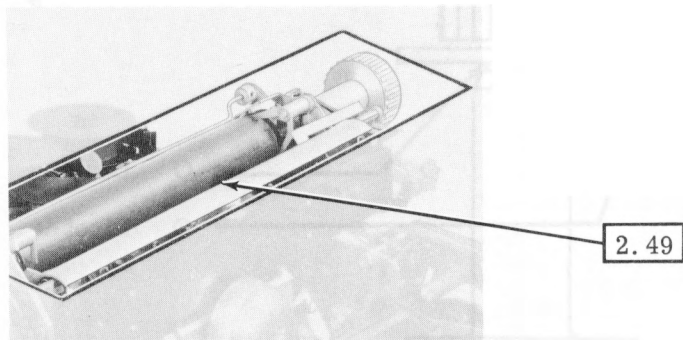

(Right Rear View)



2.49 Platen Mechanism

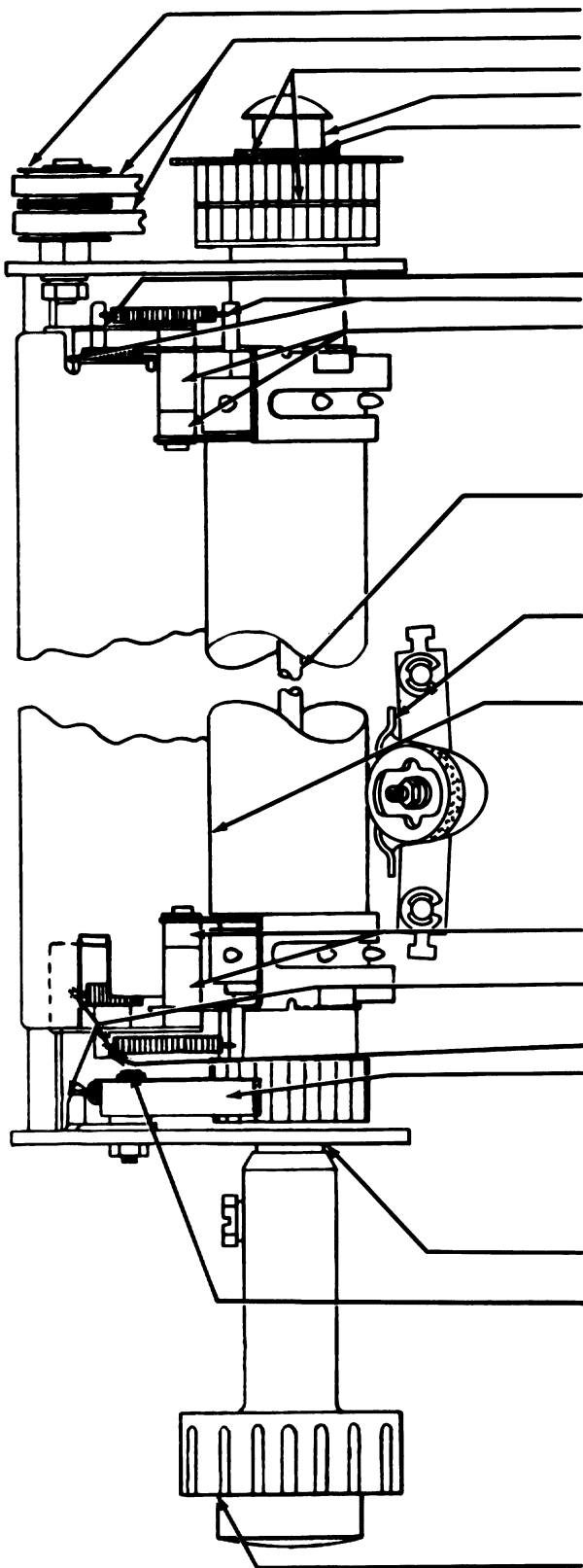

- O Bearing Idler
- D Belts Drive
- O Bearing Pulley
- O Bearing Button
- O Felt Washers (2 Within Shaft) Shaft

**Note:** Shaft must be disassembled. See appropriate disassembly and reassembly section.

- O Pivot Paper Guide
- O Hooks (Each End) Spring
- O Bearing Paper Guide

- O\* Bearings (Both Ends) Shaft

**Note:** Reassemble shaft.

- D All Surfaces Contacting Ribbon

- D All Surfaces Contacting Paper

- O Bearing Paper Guide

- O Hooks (Each End) Spring

- O Pivot Paper Guide
- O Bearing Pawl

- O Bearing Left and Right Plate

- O Pivot Detent Lever

- D Bearing Knob

(Top View)

\*Refer to 1.05.

2.50 Platen Drive Area

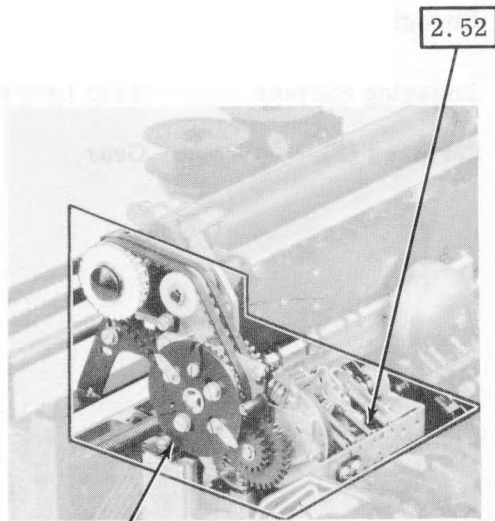

(Right Rear View)

2.51

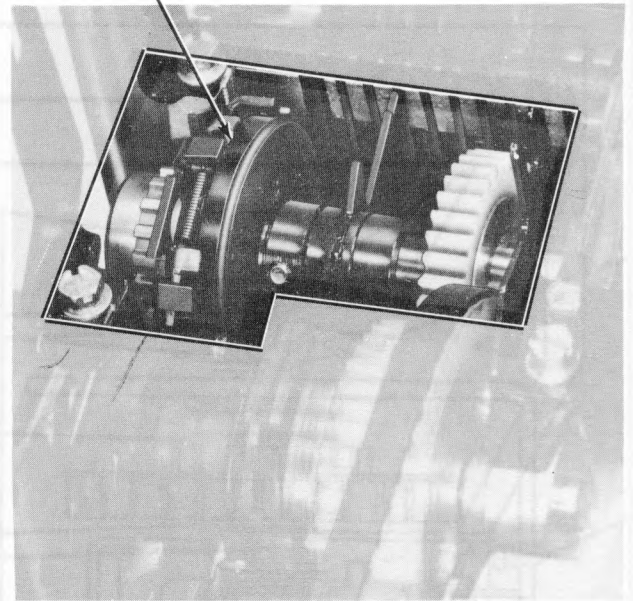

(Left Rear View)

(Form-out mechanism removed for illustration purposes. Removal for lubrication is not required.)

2.51 Cam, Pulley, and Gear Combination

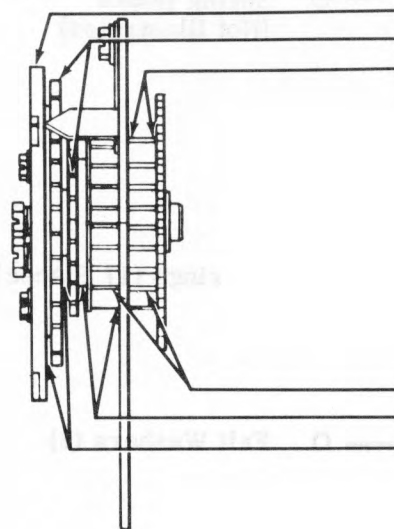

(Top View)

- |   |              |                 |
|---|--------------|-----------------|
| O | Cam Surface  | Cam Gear        |
| O | Gear Surface | Cam Gear        |
| O | Bearing      | Gear and Pulley |
|   |              |                 |
| D | Surface      | Pulley          |
| O | Bearing      | Gear and Pulley |
| O | Bearing      | Cam Gear        |

2.52 Form-Out Mechanism

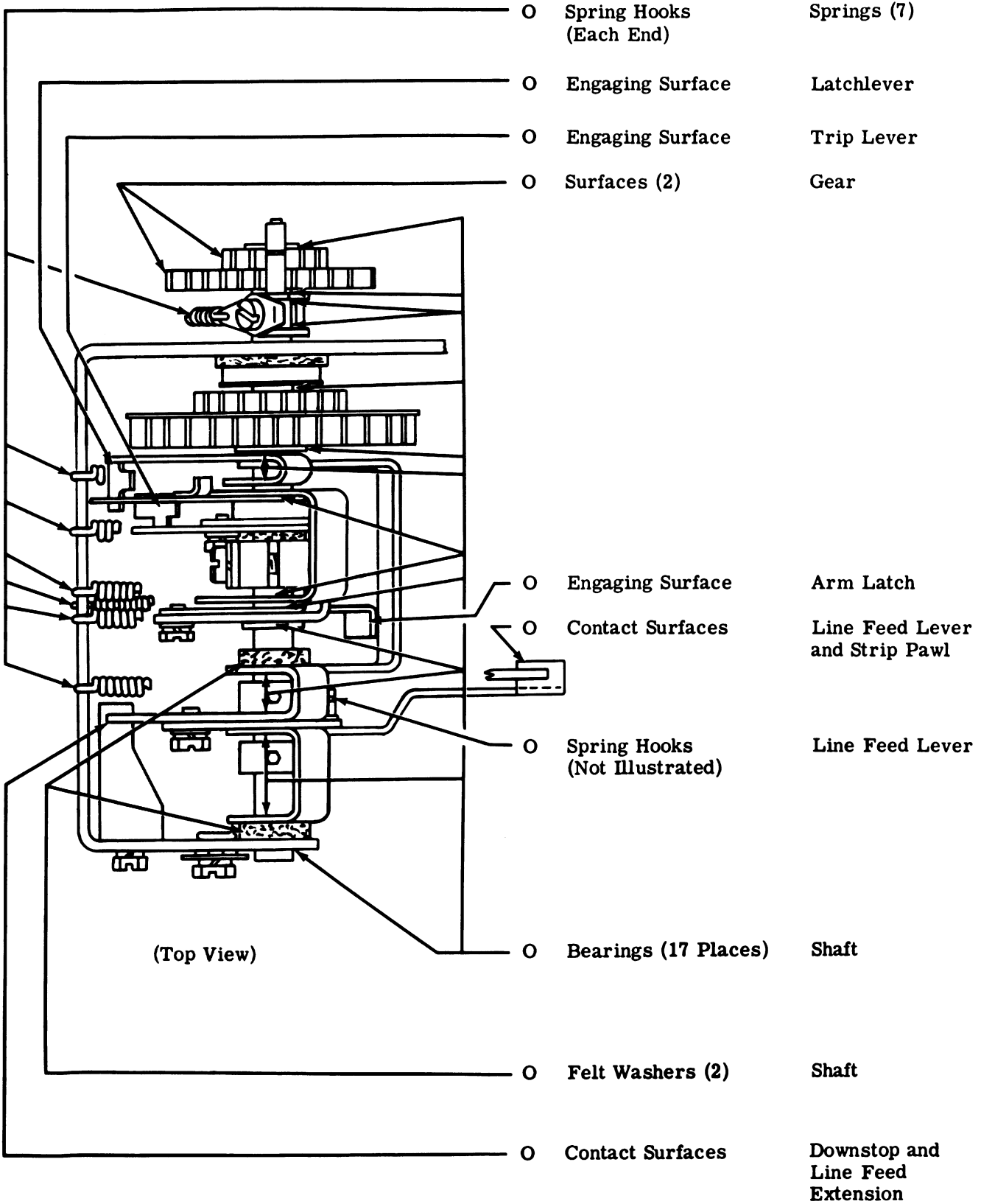

2.53 Line Feed Clutch

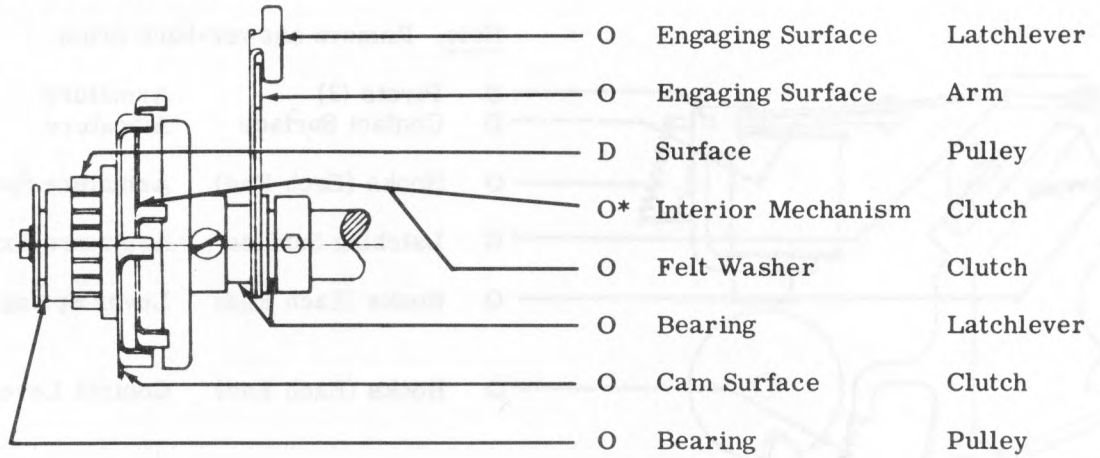

(Top View)

\* Refer to 1.05.

3. VARIATIONS TO BASIC UNITS

3.01 Answer-Back Area

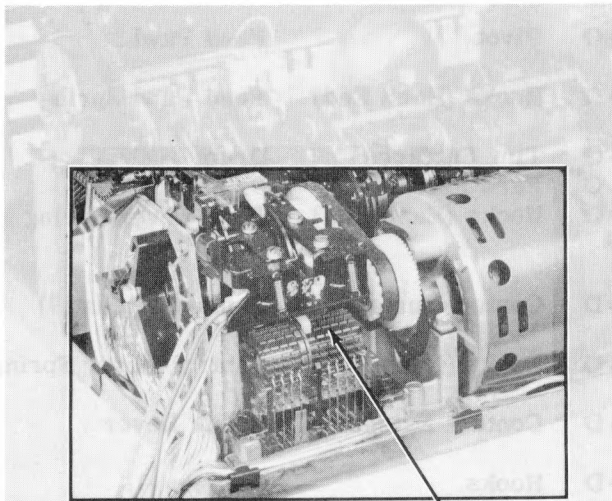

3.03

(Left Rear View)

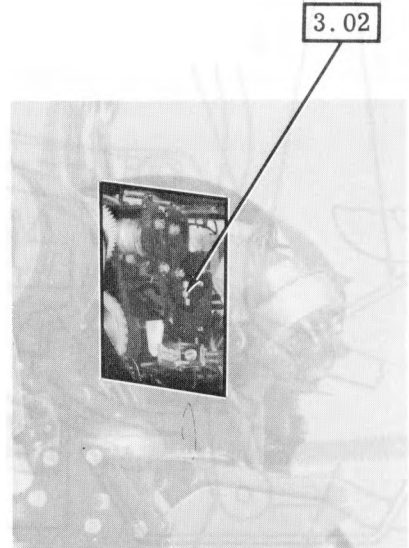

3.02

(Left Side View)

SECTION 574-122-701TC

3.02 Trip Magnet

Note: Remove answer-back drum.

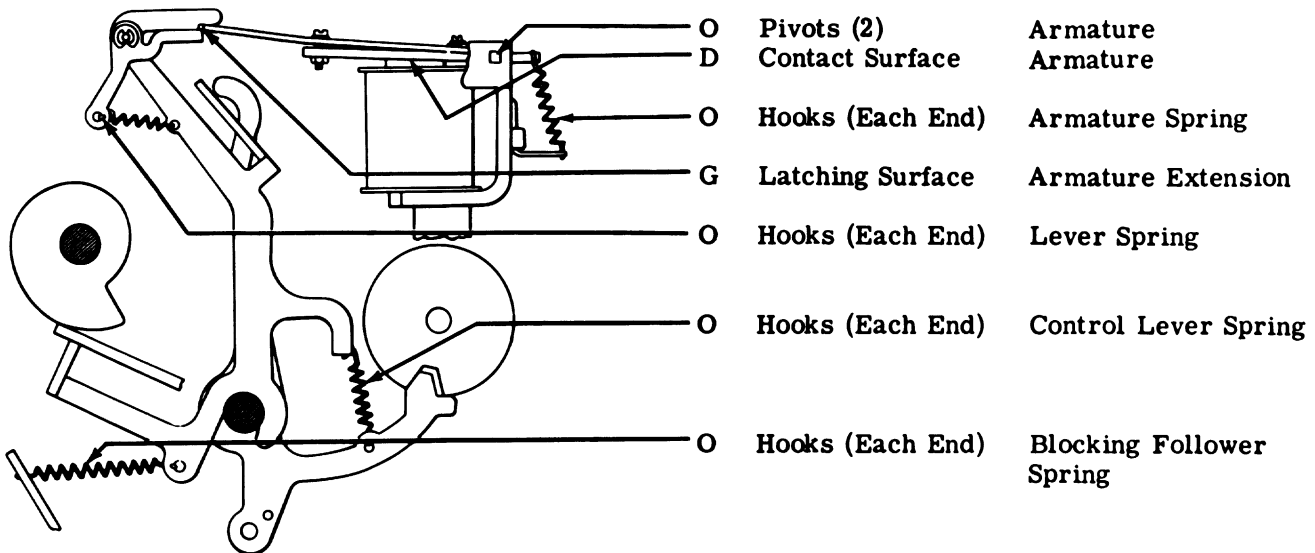

3.03 Answer-Back Mechanism

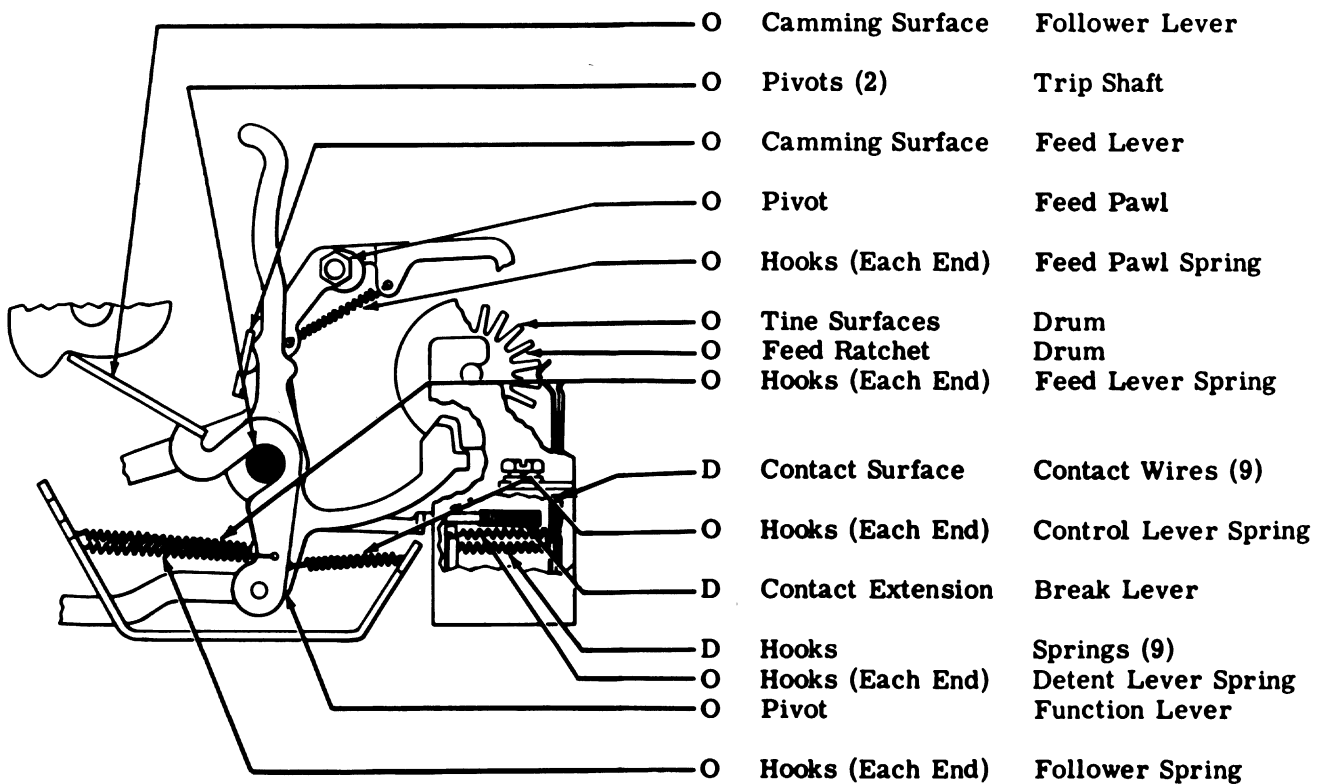

Note: Replace answer-back drum.

**CAUTION: DO NOT CLEAN CONTACT BLOCK WITH SOLVENTS.**

33 TYPING UNIT  
DISASSEMBLY AND REASSEMBLY

CONTENTS	PAGE	1. GENERAL
1. GENERAL . . . . .	1	1.01 This section is reissued to incorporate recent engineering changes and to present disassembly and reassembly information exclusively for the 33 typing unit. Since this is a general revision, marginal arrows, used to indicate changes, have been omitted.
2. DISASSEMBLY AND REASSEMBLY . .	2	
RIBBON MECHANISM . . . . .	2	
CARRIAGE MECHANISM . . . . .	2	1.02 References to left, right, front, rear, etc, consider the typing unit to be viewed from a position where the ribbon mechanism faces up and the selector mechanism is located to the viewer's left.
CARRIAGE DRIVE BAIL . . . . .	3	
CODEBAR MECHANISM . . . . .	4	
CODEBAR RESET BAIL . . . . .	4	1.03 The disassembly procedure given in this section divides the typing unit into its major assemblies and mechanisms. If further disassembly is required, refer to the appropriate illustrated parts section which shows detailed arrangements of parts. Where it will help in determining location, the numbers of the parts are given in the instructions.
SPACING PAWL MECHANISM . . . . .	4	
FUNCTION LEVER MECHANISM . . . .	5	
SPACING DRUM MECHANISM . . . . .	5	
DISTRIBUTOR TRIP SHAFT MECHANISM . . . . .	5	<b>CAUTION: BEFORE BEGINNING DISASSEMBLY, REMOVE CONNECTORS FROM EXTERNAL RECEPTACLES (POWER SOURCE, DATA SET, ETC).</b>
DISTRIBUTOR MECHANISM . . . . .	6	
FUNCTION ROCKER SHAFT MECHANISM . . . . .	7	1.04 Most of the mechanisms are mounted on castings by self-tapping screws. Therefore, to remove the mechanisms, do not remove the screws, merely loosen them unless specifically instructed otherwise.
FUNCTION BOX MECHANISM . . . . .	7	
PLATEN MECHANISM . . . . .	7	
A. Friction Feed . . . . .	7	
B. Sprocket Feed . . . . .	7	1.05 Retaining rings are made of spring steel and have a tendency to release suddenly. To avoid loss of these rings when removing them, proceed as follows.
FORM-OUT MECHANISM . . . . .	7	
TRIP SHAFT MECHANISM . . . . .	9	(a) Hold retaining ring to prevent it from rotating.
SELECTOR MECHANISM . . . . .	9	(b) Place blade of screwdriver in one of the ring's slots and rotate screwdriver to increase diameter.
MAIN SHAFT MECHANISM . . . . .	10	(c) Ring will come off easily in fingers without flying.
MOTOR . . . . .	11	

## SECTION 574-122-702TC

1.06 All tools used to remove the mechanisms referred to in this section can be found in the 570-005-800TC standard tool section.

1.07 All damaged, worn, or distorted parts should be replaced if encountered in the disassembly and reassembly procedures.

### 2. DISASSEMBLY AND REASSEMBLY

Note: For information concerning the proper procedure to remove the typing unit from the set, refer to appropriate disassembly and reassembly set section.

#### RIBBON MECHANISM

2.01 To remove ribbon mechanism (Figure 1), proceed as follows.

(a) Remove ribbon by removing the two ribbon spools and disengaging the ribbon from the ribbon guide and the TP183324 reverse arm.

(b) Loosen the two TP152893 mounting screws and lift ribbon mechanism from carriage.

(c) To replace ribbon mechanism, reverse procedure used to remove it.

#### CARRIAGE MECHANISM

2.02 To remove carriage mechanism (Figure 1), proceed as follows.

(a) Unhook carriage return spring from carriage.

(b) Loosen the two TP180798 mounting screws in spacing pulley mounting bracket. Rotate and remove bracket.

(c) Loosen the two TP180798 mounting screws in spacing drum mounting bracket. Remove mounting bracket.

(d) Disengage spacing belt from pulley on spacing drum.

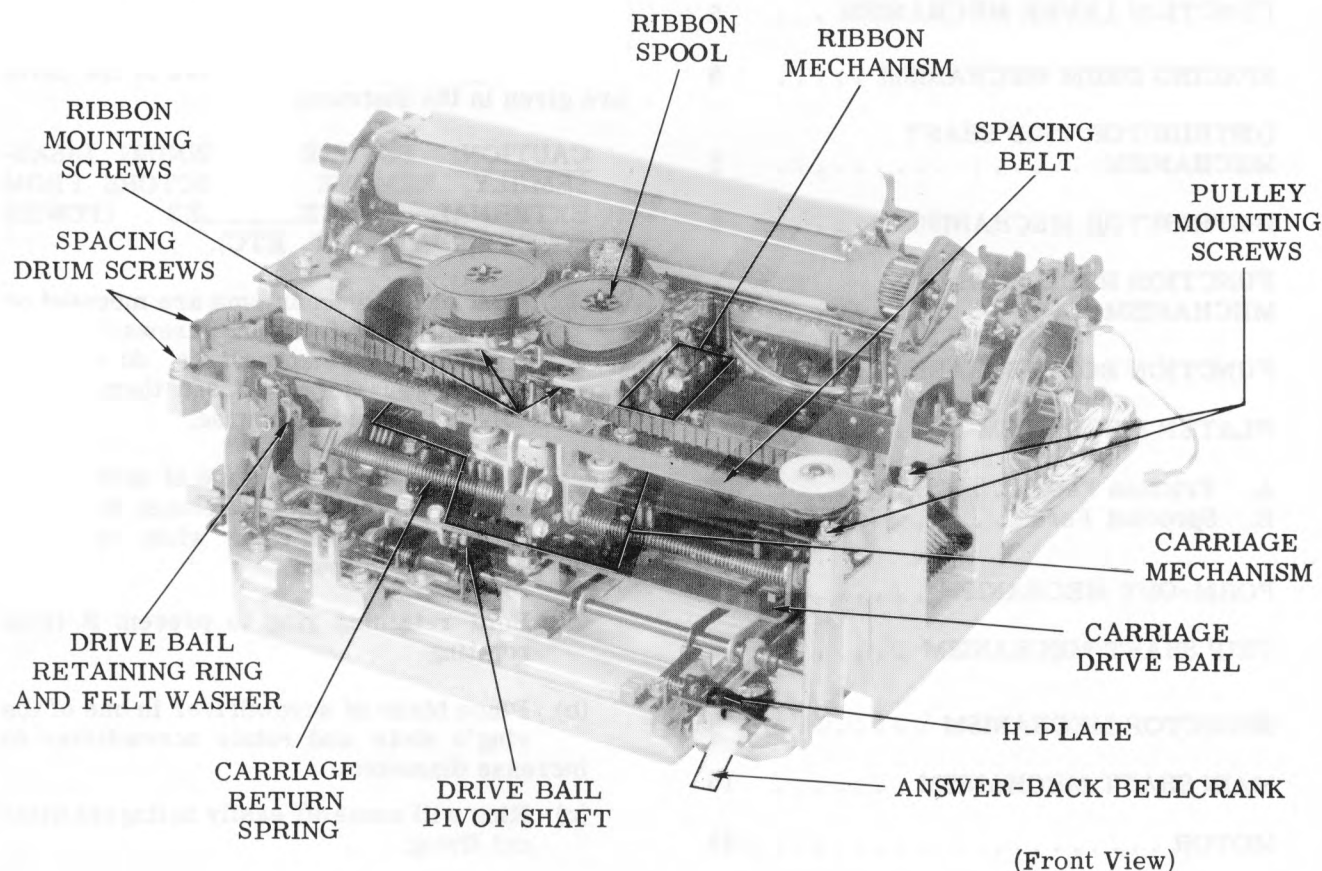

Figure 1 - Typing Unit

- (e) Remove front carriage shaft by sliding it to the right.
- (f) To disengage the rollers from the drive bail, slightly lift the front of the carriage. Rotate the carriage to the left and disengage the slide guides from the codebars.
- (g) Lift the carriage from the unit.
- (h) To replace the carriage mechanism, reverse the procedure used to remove it and observe the following precautions.

- (1) Make sure nylon slide guides engage proper associated codebars.
- (2) Make sure two rear rollers engage carriage rear plate.

**CARRIAGE DRIVE BAIL**

2.03 To remove carriage drive bail (Figures 1 and 2), proceed as follows.

- (a) Remove the carriage mechanism (2.02).

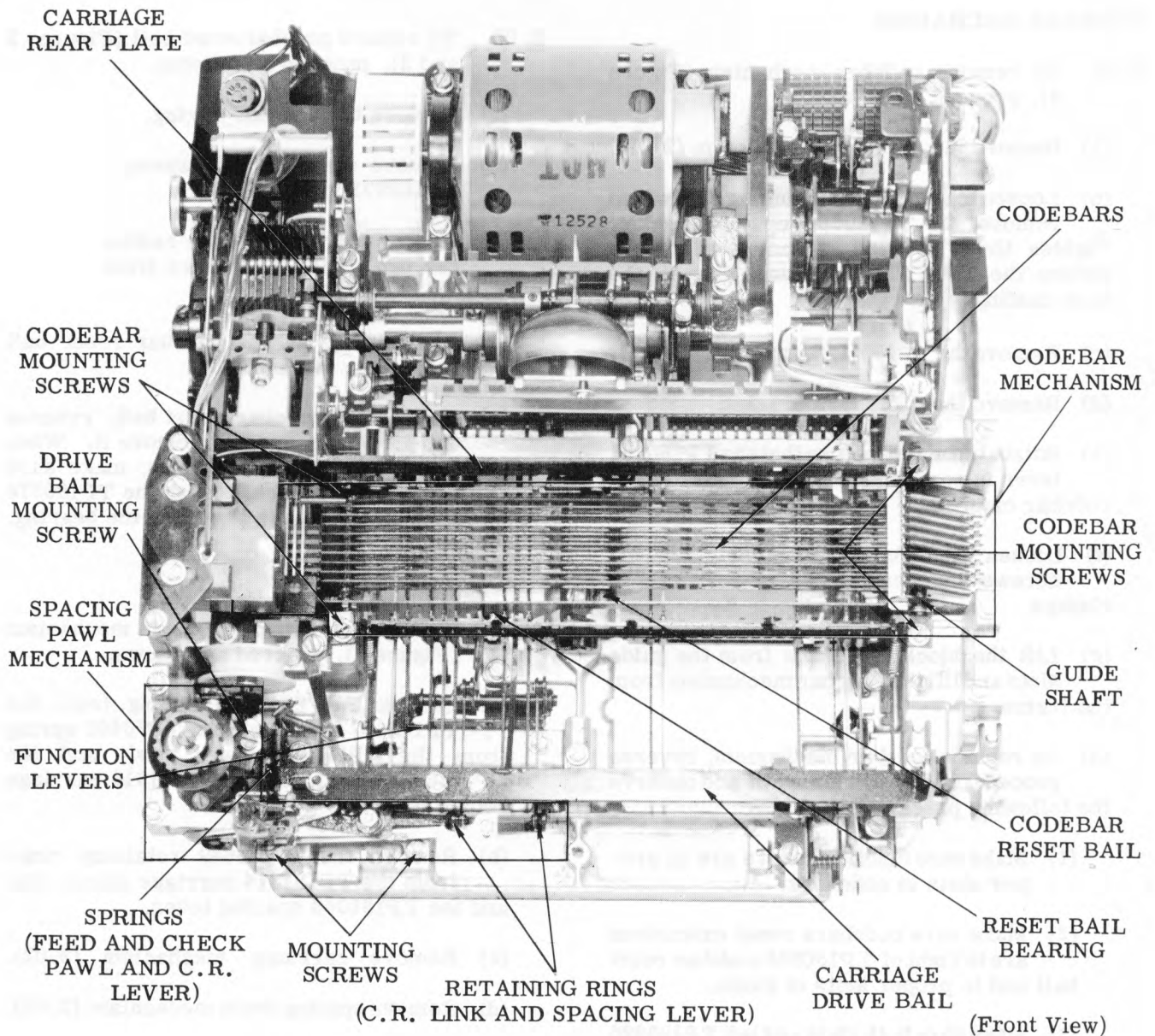

Figure 2 - Typing Unit (Carriage and Platen Removed)



## SECTION 574-122-702TC

- (b) Remove the TP3598 nut from the TP180546 post.
- (c) Loosen the TP180798 mounting screw and remove the TP181230 clamp plate at left end of carriage drive bail.
- (d) Remove the TP119651 retaining ring and felt washer at right end of bail.
- (e) Remove drive bail by sliding it to left.
- (f) To replace drive bail assembly, reverse procedure used to remove it.

### CODEBAR MECHANISM

2.04 To remove codebar mechanism (Figure 4), proceed as follows.

- (a) Remove the carriage mechanism (2.02).
- (b) Loosen the TP180798 mounting screw and remove the TP180682 upstop bracket. Tighten the TP180798 mounting screw to secure the TP181230 retaining plate to the base casting.
- (c) Remove the TP180788 carriage rear bail.
- (d) Remove the TP180959 bracket.
- (e) Rotate the main shaft so that the TP180751 lever is positioned on the low part of the codebar cam.
- (f) Loosen the four TP180798 mounting screws and remove the four TP180925 clamps.
- (g) Lift the blocking levers from the guide slots and lift the codebar mechanism from the frame.
- (h) To replace codebar mechanism, reverse procedure used to remove it and observe the following precautions.
  - (1) Make sure function levers are in proper slots in codebars.
  - (2) Make sure codebars reset extensions are to right of TP180928 codebar reset bail and in proper slots of guide.
  - (3) Make sure both right and left TP180920 guide shafts are fully seated in their mountings.

(4) Make sure the TP181070 space suppression lever is to the left of the TP180947 print suppression codebar.

(5) Make sure the TP180752 print suppression latch lever fits into slot of the TP180923 bracket mounted on the rear tie bracket.

(6) Make sure that the left ends of the codebars fully engage their respective blocking lever tines.

### CODEBAR RESET BAIL

2.05 To remove codebar reset ball (Figures 2 and 3), proceed as follows.

- (a) Remove the codebar spring.
- (b) Remove the TP125252 spring from the TP180773 plate.
- (c) From underside of base casting remove the two TP181245 screws from the two TP180930 bearings.
- (d) Lift the TP180928 codebar reset bail from base casting.
- (e) To replace codebar reset bail, reverse the procedure used to remove it. When replacing the TP181245 screws, make sure that one of them passes through the TP180776 spring bracket before it enters the bearing.

### SPACING PAWL MECHANISM

2.06 To remove spacing pawl mechanism (Figure 2), proceed as follows.

- (a) Unhook the TP74701 spring from the TP181067 feed pawl, the TP70466 spring from the TP181065 check pawl, and the TP70388 spring from the TP181319 carriage return lever.
- (b) Remove the TP119649 retaining rings from the TP181314 carriage return link and the TP181068 spacing lever.
- (c) Remove carriage mechanism (2.02).
- (d) Remove spacing drum mechanism (2.08).
- (e) Loosen the two TP180798 mounting screws.

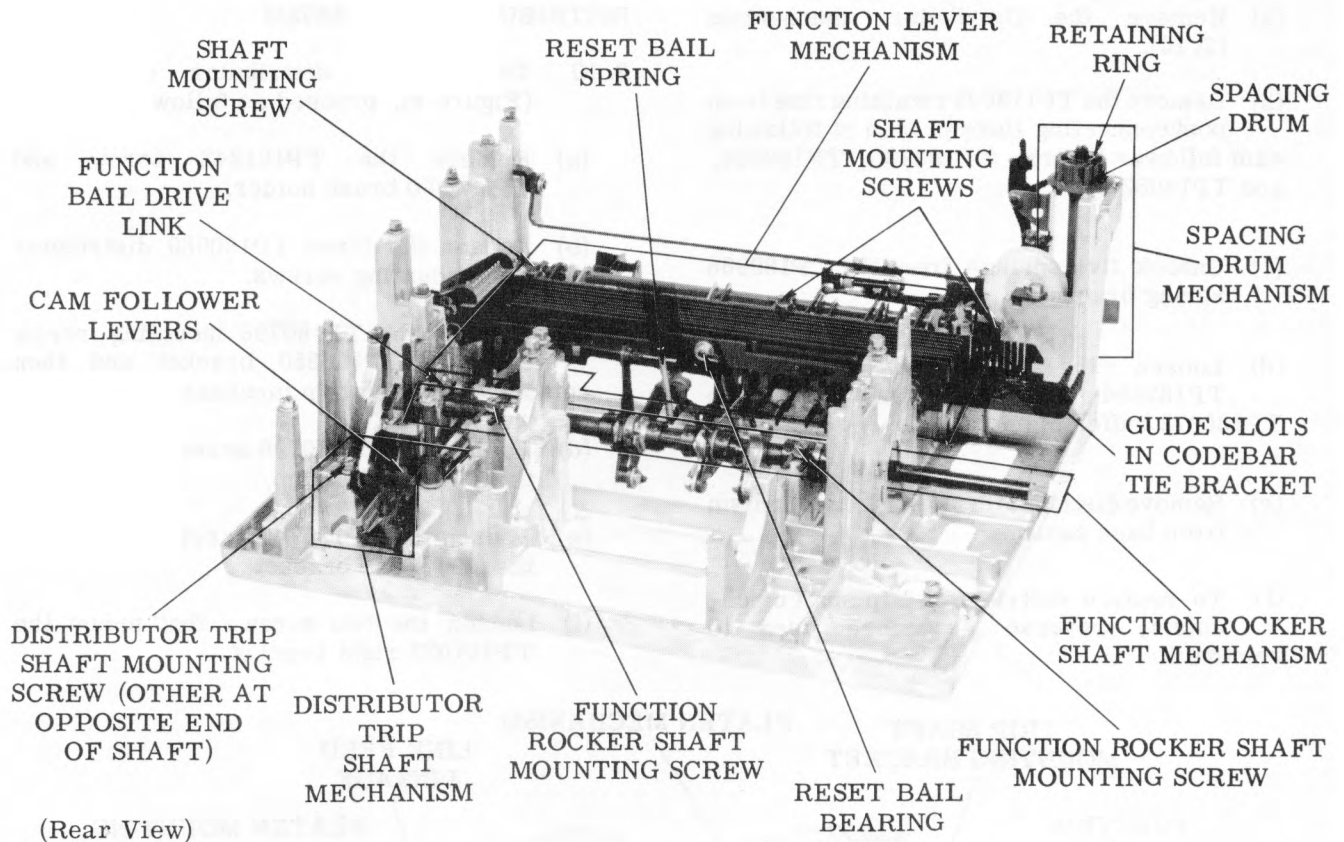

Figure 3 - Typing Unit (A Number of Mechanisms Removed)

- (f) Lift spacing pawl mechanism from base casting.
- (g) To replace spacing pawl mechanism, reverse the procedure used to remove it.

#### FUNCTION LEVER MECHANISM

- 2.07 To remove function lever mechanism (Figure 3), proceed as follows.
- (a) Loosen the three TP180798 mounting screws and rotate levers pivot shaft so flat side is vertical.
  - (b) To remove any function lever, unhook its spring and disengage lever from pivot shaft.
  - (c) To remove levers pivot shaft, remove the two TP180797 clamp plates and the TP180795 spring bracket. Lift out shaft with two drive links attached.
  - (d) To replace function lever mechanism, reverse the procedure used to remove it.

#### SPACING DRUM MECHANISM

- 2.08 To remove spacing drum mechanism (Figure 3), proceed as follows.
- (a) Remove the carriage mechanism (2.02).
  - (b) Remove the TP119653 retaining ring from top of spacing drum and remove drum.
  - (c) From underside of base casting, remove the TP112626 nut and lockwasher from lower end of spacing drum shaft.
  - (d) Lift spacing drum shaft from base casting.
  - (e) To replace spacing drum mechanism, reverse procedure used to remove it.

#### DISTRIBUTOR TRIP SHAFT MECHANISM

- 2.09 To remove distributor trip shaft mechanism (Figure 3), proceed as follows.

- (a) Remove the distributor mechanism (2.10).
- (b) Remove the TP119649 retaining ring from post connecting links to each of following cam follower levers: TP180985, TP180820, and TP180821.
- (c) Unhook five springs from the TP180988 spring bracket.
- (d) Loosen the TP180798 screw and TP182264 post, and remove the two TP180972 buffer clamps.
- (e) Remove distributor trip shaft mechanism from base casting.
- (f) To replace distributor trip shaft mechanism, reverse procedure used to remove it.

**DISTRIBUTOR MECHANISM**

2.10 To remove distributor mechanism (Figure 4), proceed as follows.

- (a) Remove the TP181242 screw and TP180980 brush holder.
- (b) Loosen the three TP180989 distributor disc mounting screws.
- (c) Remove the TP180798 mounting screw and the TP180850 bracket and then remove the clutch trip mechanism.
- (d) Loosen the TP180798 screw and remove the TP180998 clamp.
- (e) Loosen the TP156740 screw and remove the TP182263 bracket.
- (f) Loosen the two screws that mount the TP181023 right bracket.

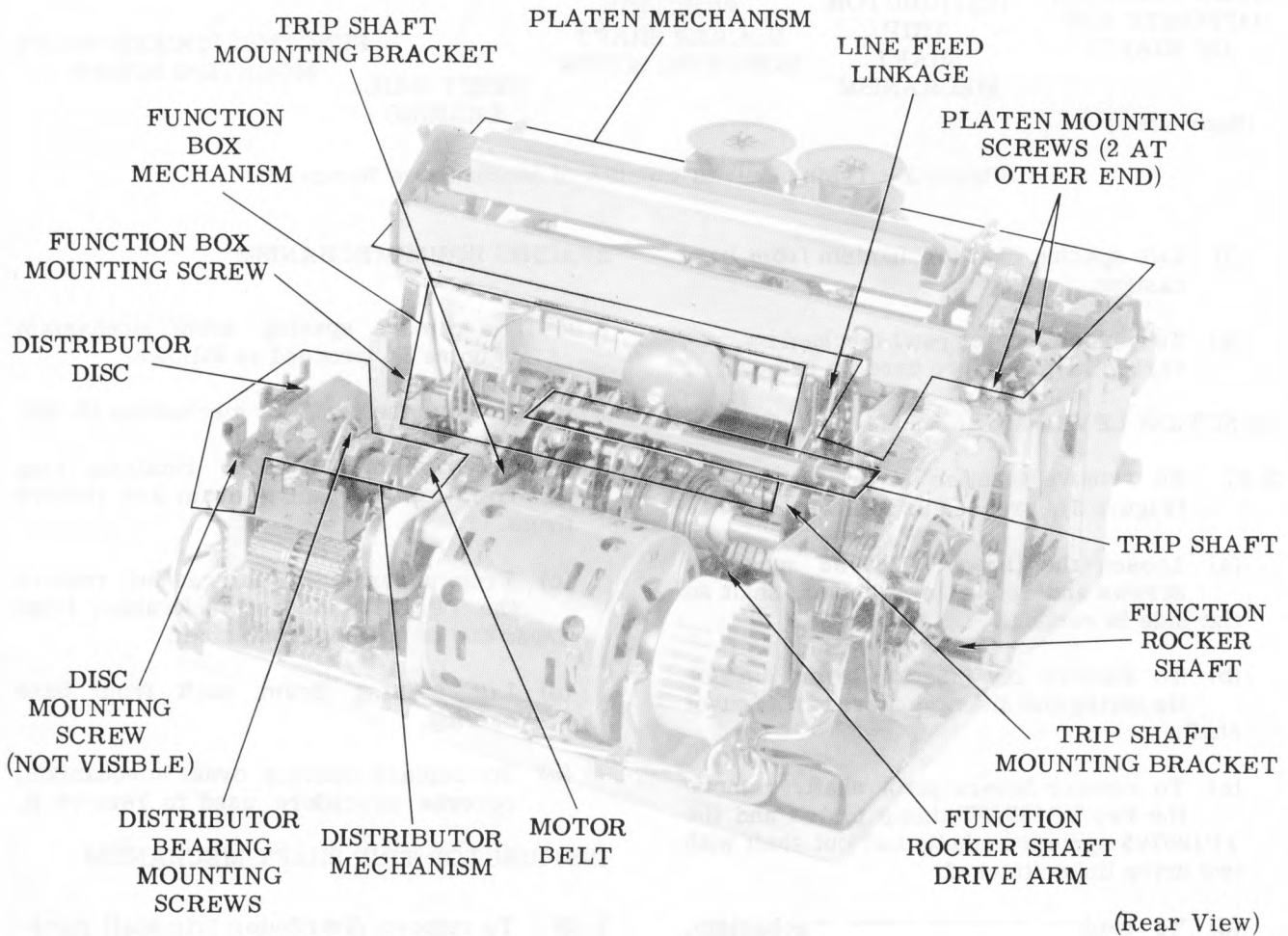

Figure 4 - Typing Unit

- (g) Remove the belt from the motor.
- (h) Lift the distributor mechanism from the base.
- (i) To replace distributor mechanism, reverse procedure used to remove it. Make sure leads are inserted into proper connections on disc. (See the appropriate wiring diagram.)

#### FUNCTION ROCKER SHAFT MECHANISM

- 2.11 To remove function rocker shaft mechanism (Figure 3), proceed as follows.
- (a) Remove the trip shaft mechanism (2.16).
  - (b) Remove the form-out mechanism (2.15).
  - (c) Remove the main shaft mechanism (2.18).
  - (d) Remove the TP119651 retaining rings from posts at rear of the TP180769 left and TP180770 right function bail drive link.
  - (e) Loosen the two TP180798 mounting screws and remove the left and right function rocker shaft bearing clamp plates.
  - (f) Lift the function rocker shaft mechanism from the base casting.
  - (g) To replace the function rocker shaft mechanism, reverse the procedure used to remove it.

#### FUNCTION BOX MECHANISM

- 2.12 To remove function box mechanism (Figures 2, 4, and 7), proceed as follows.
- (a) Remove the carriage mechanism (2.02).
  - (b) Remove the platen mechanism (2.13).
  - (c) Unhook the TP125252 spring (connects to TP180928 codebar reset ball) from the TP180773 plate.
  - (d) Loosen the two TP180798 mounting screws and remove the two TP180796 clamp plates.
  - (e) Lift function box mechanism from base casting.

- (f) To replace function box mechanism, reverse procedure used to remove it. Make sure function levers are in their proper slots and aligned with their respective pawls.

#### PLATEN MECHANISM

##### A. Friction Feed

- 2.13 To remove platen mechanism (Figure 4), proceed as follows.
- (a) Remove the TP119651 retaining ring and the TP90615 spring from line feed linkage.
  - (b) Disengage the TP181176 link from the TP181168 bellcrank.
  - (c) Loosen the four TP181242 mounting screws in the two platen side plates.
  - (d) Lift platen mechanism from typing unit.
  - (e) To replace platen mechanism, reverse procedure used to follow it.

##### B. Sprocket Feed

- 2.14 To remove platen mechanism (Figures 4 and 5), proceed as follows.
- (a) Loosen the TP3598 nut on the TP183351 idler post. Back off the two TP183341 idlers and slip the two TP183379 belts off the sprockets.
  - (b) Loosen the four TP181242 mounting screws in the two platen side plates.
  - (c) Lift platen mechanism from typing unit.
  - (d) To replace platen mechanism, reverse the procedure used to remove it.

#### FORM-OUT MECHANISM

- 2.15 To remove form-out mechanism (Figures 4 and 5), proceed as follows.
- (a) With the typing unit removed from sub-base, remove the TP181242 mounting screw which secures the TP180980 brush holder.
  - (b) Remove brush holder and brush.

Note: Reader feed contact assembly and certain contact wiring removed.

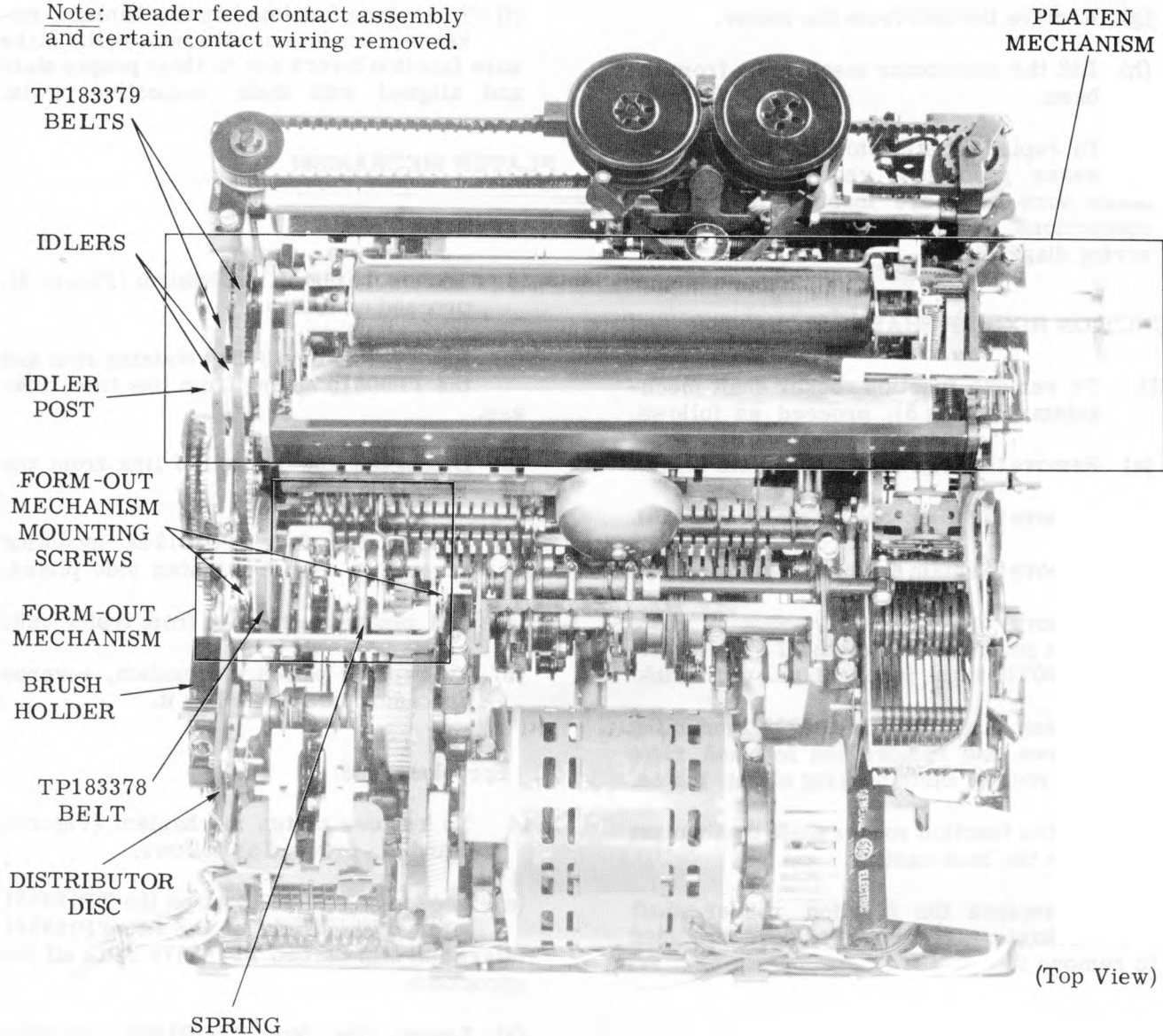

Figure 5 - Typing Unit

Note: On Automatic Send-Receive Teletypewriter Sets, remove the front TP152893 and loosen the rear TP152893 contact bracket mounting screws which secure the tape reader feed magnet contact assembly to the typing unit. Rotate the tape reader feed magnet contact assembly out of the way clockwise, as viewed from the right.

(c) Loosen the two TP180989 distributor disc mounting screws and pull the distributor disc out of the way.

Note: It is not necessary to remove wires from the distributor disc.

(d) Loosen the TP3598 nut on the TP183351 idler post. Back off the two TP183341 idlers.

(e) Slip the two TP183379 belts off the sprockets.

(f) Loosen the three TP151630 form-out mechanism mounting screws.

(g) Slip the TP183378 belt off main shaft sprocket.

(h) Disengage the TP90891 spring from form-out latchlever assembly.

- (i) Gently work form-out mechanism upward and remove it.
- (j) To replace the form-out mechanism, reverse the procedure used to remove it.

Note: When tightening the three distributor disc mounting screws, be sure that the longer edges of the TP180676 speed nuts are horizontal with the base casting.

#### TRIP SHAFT MECHANISM

- 2.16 To remove trip shaft mechanism (Figure 4), proceed as follows.

- (a) Loosen the four TP180798 mounting screws, two in the left and two in the right mounting bracket. Push inward on brackets and lift mechanism from base casting.

- (b) To replace trip shaft mechanism, reverse procedure used to remove it.

#### SELECTOR MECHANISM

- 2.17 To remove selector mechanism (Figure 6), proceed as follows.

- (a) Install the TP184098 selector cam removal tool as described on instruction label.
- (b) Remove the TP150040 mounting screw with lockwasher from selector clutch.
- (c) Remove selector clutch from main shaft by pulling clutch to left and rotating it back and forth.
- (d) From underside of base casting, remove the TP180798 mounting screw from bottom of left platen support post. Loosen

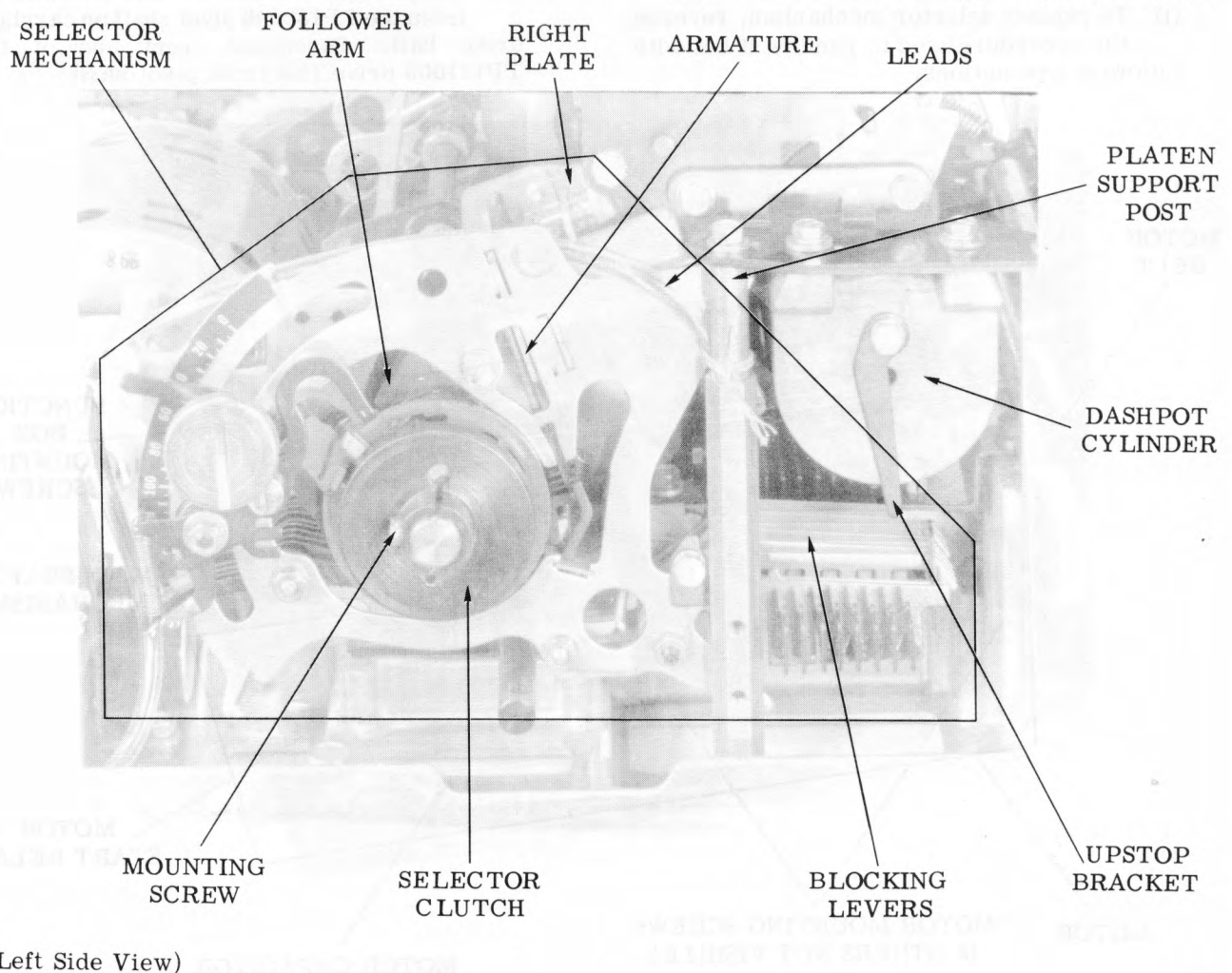

Figure 6 - Selector Mechanism

SECTION 574-122-702TC

the TP180798 screw in top of post and remove it and dashpot cylinder.

(e) Loosen the TP181246 mounting screw in the TP180648 follower arm. Slide arm off trip shaft.

(f) Loosen the TP180798 mounting screw and remove the TP180682 upstop bracket. Tighten screw to secure the TP181230 retaining plate.

(g) Remove the three TP180675 mounting screws with the TP180676 speed nuts from selector plate.

(h) Remove the two leads from the selector magnet.

(i) Remove selector mechanism.

(j) To replace selector mechanism, reverse the procedure used to remove it but with following precautions.

(1) Make sure blocking levers are properly seated to guide slots in the front TP180950 codebar tie bracket.

(2) To prevent right plate from bending, make sure it is properly fitted around the TP181006 bearing on main shaft.

MAIN SHAFT MECHANISM

2.18 To remove main shaft mechanism (Figure 7), proceed as follows.

(a) Remove trip shaft mechanism (2.16).

(b) Remove selector mechanism (2.17).

(c) Remove motor (2.19).

(d) Remove form-out mechanism (2.15).

(e) Remove the TP3598 nut and flat washer from the TP180546 pivot shaft on carriage drive bail. Disengage front end of the TP181005 drive link from pivot shaft.

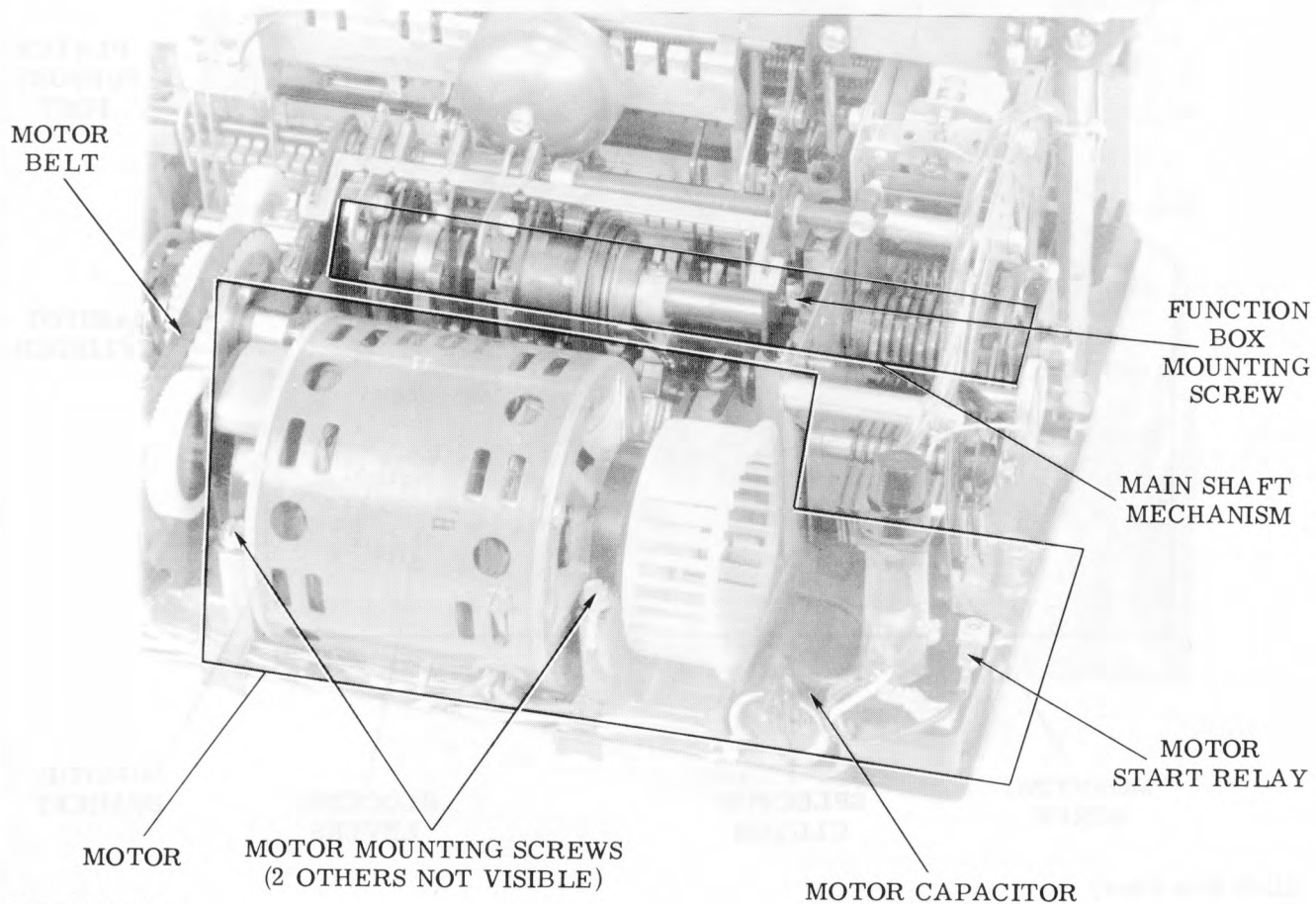

(Rear View)

Figure 7 - Typing Unit

- (f) Remove the TP119651 retaining ring from function rocker shaft TP180774 drive arm. Disengage the TP180746 arm on function rocker shaft from drive arm.
- (g) Position main shaft mechanism to the right and lift it from base casting.
- (h) To replace main shaft mechanism, reverse procedure used to remove it. Make sure distributor shaft is properly positioned to left against pressure of brush spring.

**MOTOR**

- 2.19 To remove motor (Figure 7), proceed as follows.

- (a) Remove the four TP180798 mounting screws and the two TP181383 motor clamps.
- (b) Disengage motor belt from gear pulley mounted on motor housing.
- (c) Loosen the TP180798 screw in motor start relay.
- (d) Remove motor, motor capacitor, start relay, and associated wiring.
- (e) To replace motor, reverse procedure used to remove it.





33 CALL CONTROL UNIT

GENERAL DESCRIPTION

AND OPERATION

CONTENTS	PAGE
1. GENERAL . . . . .	1
2. DESCRIPTION AND OPERATION . . . . .	1
CALL CONTROL UNIT FOR CIRCUIT SWITCHING SERVICE . . . . .	1
A. Neutral Operation . . . . .	1
B. Polar Operation . . . . .	3
CALL CONTROL UNIT FOR SWITCHED NETWORK SERVICE . . . . .	4
CALL CONTROL UNIT FOR PRIVATE WIRE SERVICE . . . . .	10

1. GENERAL

1.01 This section provides a general description and operation of the 33 call control unit only. This information was formerly contained in Section 574-123-101TC, covering both the 32 and 33 call control units, which is hereby cancelled. The circuit description contained in that section is now covered in Section 574-100-103TC. The 32 information is now found in Section 574-173-100TC.

1.02 This section describes three call control units which may be considered basic units. They are:

- (1) Call Control Unit for Circuit Switching Service
- (2) Call Control Unit for Switched Network Service
- (3) Call Control Unit for Private Wire Service

1.03 The call control unit is the electrical link which joins the various components of the set to one another and the set to the transmission facilities.

1.04 References to left, right, front, or rear consider the call control unit as viewed by the operator.

2. DESCRIPTION AND OPERATION

CALL CONTROL UNIT FOR CIRCUIT SWITCHING SERVICE (Figure 1)

2.01 The call control unit for Circuit Switching Service utilizes two types of signals in its operation. Over short and intermediate length telegraph loops it operates on neutral signals; over longer loops with excessive distortion it operates on polar signals. A polar adapter attached to the call control unit enables it to operate on polar signals. Paragraphs 2.02 through 2.14 describe the neutral operation. Paragraphs 2.15 through 2.20 describe the polar operation.

A. Neutral Operation

Controls

2.02 The controls on the call control unit used to originate and handle calls consists of a set of push-buttons and dialer. In certain applications the pushbutton designations are, from left to right, as follows: START, DIAL, LOCAL, and CONN(STOP). In other applications the pushbutton designations are, from left to right: REQUEST, CONN, LCL, and DISCONN.

Dialer

2.03 The dialer is a conventional telephone type which operates normally closed pulsing contacts. These contacts open and close to send dialing pulses during the dial run-down interval. The pulses are produced at a rate of ten per second with the contacts open for 0.006 + 0.003 second during each pulse interval. A pair of normally open off-normal contacts close when the dial wheel is rotated from its idle position. These contacts provide a steady mark current to "blind" the selector when dialing is undertaken. This prevents the printing of spurious characters if dialing is necessary when in the connected condition as in multiaddress calling.

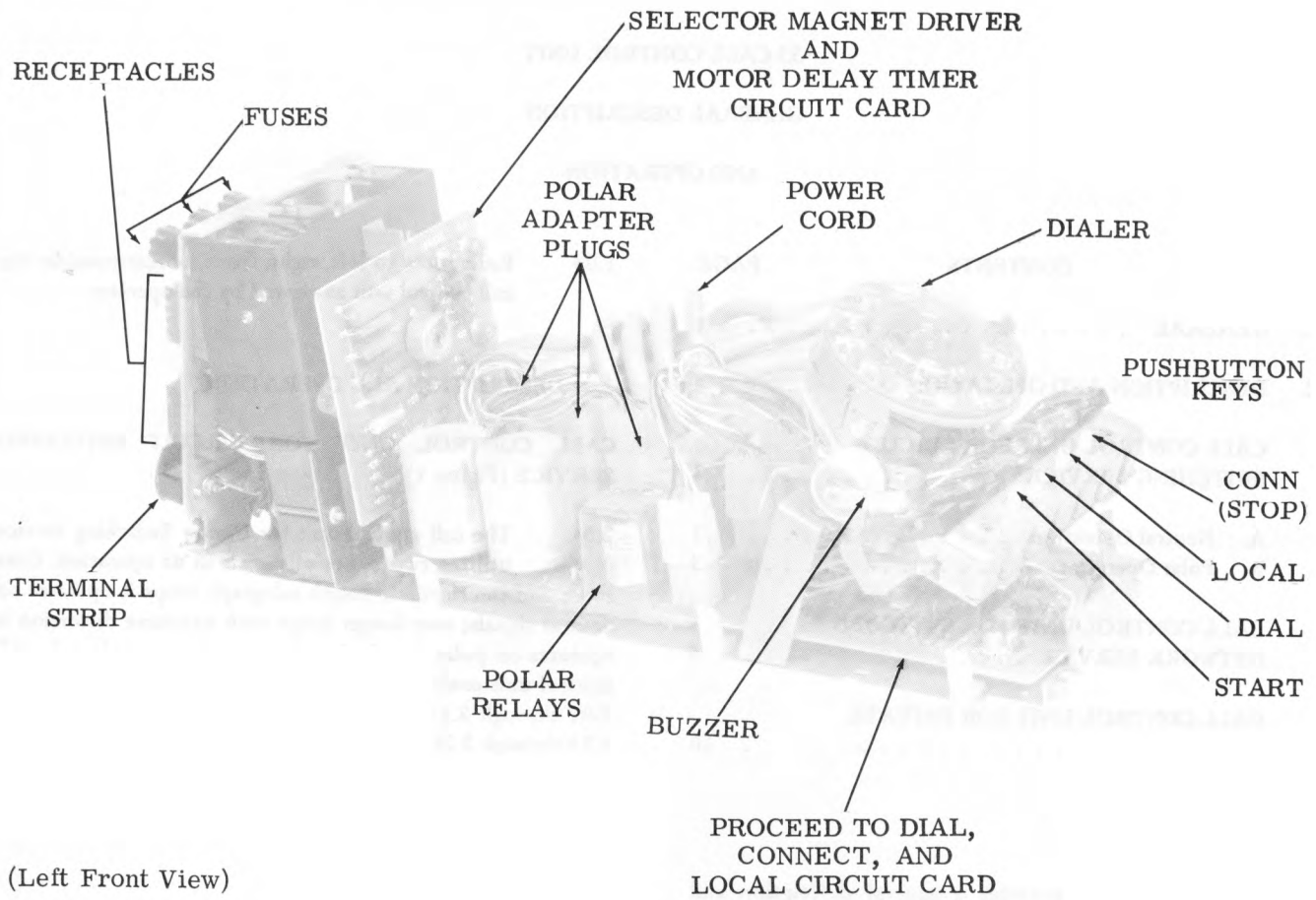

(Left Front View)

Figure 1 - Call Control Unit for Circuit Switching Service

Start

2.04 In the idle condition, with the motor and typing unit stopped and visual indicators de-energized, there is a positive current of 0.005 ampere in the telegraph loop. When the calling station operator depresses the START pushbutton, it causes the shunting of a major portion of the loop resistance, and the loop current increases to 0.060 ampere. The START pushbutton must be held in the depressed position, while switching apparatus in the telegraph exchange is made available. When the circuit is ready, the telegraph exchange interrupts the 0.060 ampere loop current for about 0.025 second. This "proceed-to-dial" signal causes the DIAL lamp to be illuminated at the calling station, and it locks in the shunt to the loop resistance so that the operator may now release the START pushbutton and proceed to dial the number of the called station. Rotation of the dial transmits signals consisting of no current for 0.06 second

followed by full current (0.060 ampere) for 0.04 second during each dial pulse interval. When dialing is completed, the exchange furnishes the connection and signifies this by reversing the telegraph loop current from positive to negative which causes the typing unit motor to start and the CONN lamp to light. Message transmission can now be exchanged between the connected teletypewriters. The line signals are 0.060 ampere marking and zero current spacing.

2.05 If the distant called station is busy or disabled at the time of a call, the local telegraph exchange reverses the local loop current from positive to negative for about 0.2 second and then causes it to revert to positive current again. This causes the local motor to start and the CONN lamp to light momentarily, but they then both turn off. The teletypewriter returns to the idle condition as the positive current is detected.

## Connect

2.06 The local telegraph exchange responds to an incoming call by reversing the idle signal loop from positive to negative current. At the local station, the CONN lamp is illuminated, and the motor is turned on as the shunt to the loop resistance is applied in response to the current change. Message transmission can now take place with unattended service at the receiving station.

## Stop

2.07 Following completion of traffic a disconnect can be originated from either the calling or the called station. Holding the STOP pushbutton depressed causes the line to go open (zero current). In approximately 3 seconds the local exchange causes the connection to the distant station to be broken, and it reverses the current in the local loop so that positive current flows – limited by the local station loop resistance. This turns off the motor and extinguishes the CONN lamp. The STOP pushbutton is released after the CONN lamp goes out. The original idle condition is now restored. When a disconnect is initiated from a remote station, the local exchange recognizes the open line interval and breaks the connection. The loop current is reversed back to positive, and the local station is returned to the idle condition as stated above.

## Local

2.08 Local Operation is provided by depressing the LOCAL pushbutton until the LOCAL lamp is turned on. This places the teletypewriter in an off-line operating condition for copy preparation, practice, or maintenance purposes. To return to the idle condition, the STOP pushbutton is held operated until the lamp is extinguished, or a call can be initiated by depressing the START pushbutton directly. If a call is received while the teletypewriter is in the local condition, the buzzer will sound for an interval of 2.6 seconds, and the teletypewriter will automatically shift over to the call-connected condition with the CONN lamp illuminated.

## Fuse Protection

2.09 Three fuses protect the components in the call control unit from accidental shorts or overloads. The selector magnet driver fuse is 0.375 amp, slow blowing, protecting the SMD circuit; the typing unit motor fuse is a 3.2 amp, slow blowing; the third fuse is the ac line fuse, 3.2 amp, slow blowing.

## Electrical Interconnections

2.10 There are eight nylon terminal blocks at the rear which serve to interconnect the set components to the call control unit. Also located at the rear is a terminal strip for the signal line and ac power connections.

## Circuits

2.11 There are three basic and two auxiliary circuits in the call control unit. The three basic circuits are: The proceed to dial circuit; the connect circuit; and the local circuit. The two auxiliary circuits are: the selector magnet driver circuit and the motor delay timer circuit.

2.12 The three basic circuits are essentially binaries (flip-flops) that have been modified to perform a specific function. They are protected with a diode arc suppressor against transients and voltage pulses generated by their associated relays and coils. They are protected from transient noise induced into them from leads in the cable to the dial, pushbutton keys, and lamp assembly. A low-pass filter or delay network of the RC type is placed in the feedback loop in each binary. The delay network slows the response time of the associated binary (0.001 second in the proceed to dial circuit; 0.02 second in the connect circuit). This reduces its susceptibility to noise. The signal line inputs are filtered against spurious noise occurring on the signal line.

2.13 The selector magnet driver circuit delivers marking signals of 0.500 ampere and spacing signals of essentially 0 ampere to the typing unit selector magnet. The signals trigger the selector magnet driver circuit at about half the current level for normal (0.060 ampere mark) neutral input signals. In teletypewriters modified for polar operation, the signal is applied to polar-to-neutral converting circuits and then to the selector magnet driver. The selector magnet driver circuit thus functions as an amplifying relay which improves the margin of operation over either neutral or polar line circuit.

2.14 The motor delay timer circuit provides a means to delay motor turn-off in the set. This allows the set to complete its printing cycle and come to rest before the motor begins to stop. This circuit is mounted on the same circuit card assembly with the selector magnet driver, but the circuit is electrically independent of it. At 25 degrees C with 390 ohm output load, the delay of the motor delay timer is from 0.475 second to 0.675 second when the supply voltages are within 3 percent of their nominal values.

## B. Polar Operation

2.15 Call control units that are modified for polar operation respond to and transmit polar telegraph signals on separate receiving and sending legs extending to the telegraph exchange facilities. The operating conditions and sequence are similar to that for neutral signaling.

2.16 In the idle condition the sending and receiving legs each have from 0.015 to 0.040 ampere positive current flowing. The sending leg current is supplied by the call control unit, and the receiving leg current is supplied by the central exchange. At the local station the polar adapter

**SECTION 574-123-100TC**

interconnects the legs with the neutral signaling control and teletypewriter circuitry. Operation of the START push-button causes the current in the sending leg to reverse to a negative polarity with a value equal to the positive current formerly applied (0.015 to 0.040 ampere). The telegraph exchange responds by reversing the current to negative on the receiving leg for 0.025 second. This causes illumination of the DIAL lamp at which time the START pushbutton should be released. The dialing signals go out over the sending leg in polar form with each pulse interval consisting of 0.06 second of positive current followed by 0.04 second of negative current. When the connection is completed, the exchange reverses the polarity of the receiving leg from positive to negative current. After 0.08 second of this reversal, the call control unit causes the motor to turn on, and the CONN lamp to be illuminated. Traffic can now be exchanged. Each station is arranged to record its transmitted copy. Transmitted and received signals consist of positive current for space and negative current for mark on both signal legs.

2.17 When receiving an incoming call, the local exchange reverses the receiving leg current from positive to negative. The local call control unit, after 0.08 second of negative current, turns on the motor and the CONN light and causes the sending leg current to be reversed from positive to negative.

2.18 If the distant station that is called is busy, it will result in the momentary application of negative current to the local receiving leg followed by a return to a continuous positive current. The motor may run briefly, but the teletypewriter will be quickly placed back into the idle condition.

2.19 In effecting a disconnect, operation of the STOP pushbutton causes the transmission of positive current on the sending leg. The exchange will then reverse the current on the receiving leg to positive as it breaks connection to the distant station. The call control unit detects the positive current. After 1.3 seconds it turns the motor and CONN lamp off as it applies a steady positive current to the sending leg and restores the teletypewriter to the idle condition. If the disconnect is initiated at the distant teletypewriter, the positive current disconnect signal, when applied to the local receiving leg, causes the local teletypewriter to go into the idle condition after 1.3 seconds, and the sending loop becomes positive again.

2.20 For local operation the interval conditions are the same as for neutral signaling. Externally, the signal legs remain on positive current unless a call is received. When a call is received, a negative current on the receiving leg for 0.08 second causes the buzzer to sound for 2.6 seconds. Following the buzzer sound, teletypewriter shifts to the call-connected condition.

**2.21 Technical Data**

**Dimensions (Approximate)**

Width . . . . . 5 inches  
Length . . . . . 17 inches  
Height . . . . . 6 inches

Input . . . . . 115 v ac + 10%, 60 Hz + ½%  
Polar adapter input . . . . . 117 v ac + 10%, 60 Hz

**Power consumption**

Neutral operation . . . not exceeding 22.5 watts  
Polar operation . . . . not exceeding 52.5 watts

Environmental conditions . . . . . 40° F to 110° F  
ambient temperature

**CALL CONTROL UNIT FOR SWITCHED NETWORK SERVICE**

2.22 The call control unit for switched Network Service (Figure 2) supplies dc signals to a data set. The data set modulates these signals into tone frequencies which are transmitted over the telephone lines. A data set at the receiving station demodulates the tone frequencies back to dc signals which are then handled by the call control unit for operation of the teletypewriter set. For a better understanding of the call control unit paragraph 2.23 briefly describes the data set.

2.23 Start-stop dc signal pulses form essentially a square wave which cannot readily be transmitted over telephone lines. The data set is basically a converter which changes the dc signals from the sending or calling station into frequency-shifted tones for transmission over the telephone network. A marking pulse from a sending station is converted to a 1270-hertz marking signal (F1 mark) and a spacing pulse becomes a 1070-hertz spacing signal (F1 space). The data set at the receiving or called station sends a 2225-hertz marking signal (F2 mark) and a 2025-hertz spacing signal (F2 space). During transmission of a message the calling station sends a mark and space tones (F1 mark and space) while the called station sends a continuous mark tone (F2 mark). In this way the telephone facilities are operated on a full duplex basis. If the signal received at either station (F1 mark and space at the called station and F2 mark at the calling station) shifts to a space tone for more than one second, or if the received signal is lost for one second, the data set will cause the station to be disconnected. This provides assurance that the connection is maintained for the entire period of message transmission.

2.24 The call control unit used with the data set operates with conventional telephone central offices that have the necessary routing and accounting facilities.

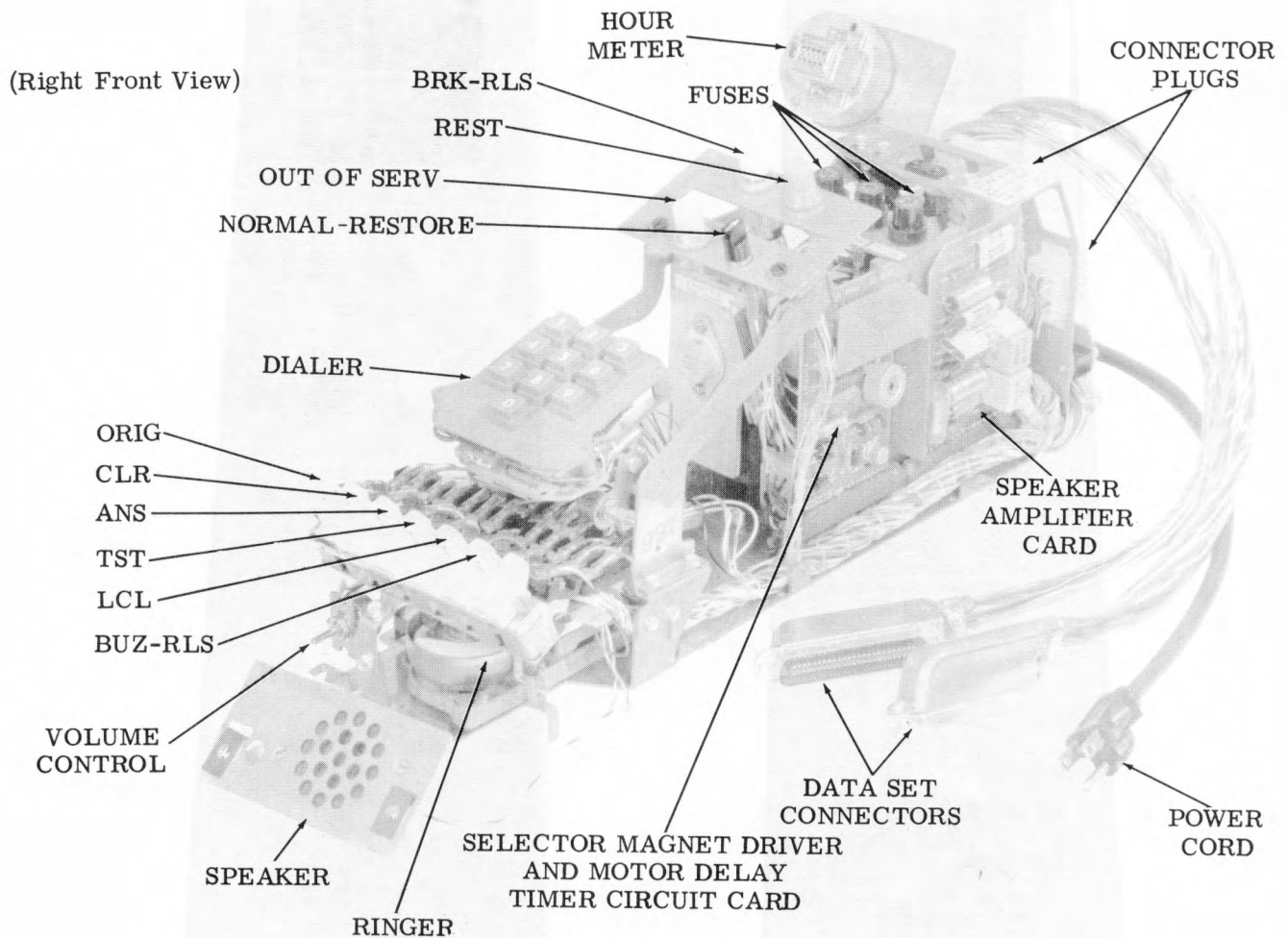

Figure 2 - Call Control Unit for Switched Network Service

In operation, a call is originated by depressing the ORIG pushbutton (Figure 3). A lamp illuminates the pushbutton and the dial tone will be heard through a loudspeaker. If the line is busy, a busy signal will be heard and the clear (CLR) pushbutton (nonlocking) should be depressed. If the line is not busy, the operator dials the number of the desired station. This causes the called station to go into connect condition. If the teletypewriter is manually operated, the called station operator presses the answer (ANS) pushbutton (nonlocking). Following a short interval, about 1-1/2 seconds, in which telephone facilities are connected, the called station transmits a mark tone (F2) and receives a mark tone (F1) from the calling station. Receiving the continuous F2 mark tone from the called station for 1 second causes the

calling station to go into connect condition, and its motor is turned on. Likewise, the continuous F1 mark tone from the calling station for 1 second causes the called station to go into connect condition, and its motor is turned on. Either station can now transmit.

2.25 At the end of the message, either station may originate a disconnect by depressing the CLR pushbutton, (Figure 3) at which time each station goes back to its idle condition, ready to receive or originate other calls. For keyboard practice, maintenance purposes, or preparation of copy, the local mode (LCL) pushbutton (locking) is depressed. This turns on the motor and disables automatic answering facilities, if present. In the event of an incoming



Figure 3 - Call Control Panels

call during local operation, the call control unit responds to ringing signals and the ANS pushbutton must be operated manually. Operation of the test (TST) pushbutton (locking) causes received signals to be retransmitted to the test center for maintenance purposes. A lamp, associated with each pushbutton, illuminates the pushbutton whenever that pushbutton has been operated and the operating condition exists. The ANS lamp is pulsed in response to ringing signals of an incoming call, and lights continuously when the call is answered. The CLR lamp is automatically extinguished 1.5 seconds after the pushbutton has been depressed, and disconnect is completed.

2.26 A steady mark signal blinds the associated teletypewriter during all intervals, except when in the connect condition. This prevents spurious characters from being printed except when due to loss of signals, circuit noise, or deliberate break or space-disconnect signals.

#### Progress of a Call

2.27 To originate a call, the ORIG pushbutton (Figure 3) is momentarily depressed. This connects the station to the line and lights the ORIG lamp. During the period of time in which connection is being made, the telephone central office makes no time measurements. When the ORIG pushbutton is closed, the call control unit is connected to the telephone line through the data set and an off-hook condition is set up. The amplifier is connected into the circuit so that the dial tone from the central office is heard. The called station is dialed while the amplifier monitors the progress.

2.28 At the called station audible and visible signaling devices are operated. The called station goes off hook and into the connect condition upon operation of the ANS pushbutton circuit, by manual or automatic means, at the distant point. At this time, there is a nonsignaling interval of 1.225 seconds during which accounting and toll recording facilities at the telephone exchange will be cleared. Following the nonsignaling interval, the called station transmits its F2 mark tone and sets its monitoring timer to respond to the F1 mark tone from the calling station. When the continuous F2 mark tone is received at the calling station for a period of 1 second, indicating that a station has answered, it will go into the connect condition and turn on its motor. When the continuous F1 mark tone is received at the called station for an interval of 1 second, it will go into the connect condition. The station may now acknowledge the call either by operator keyboarding, or by automatic answer-back message transmission. The monitoring timers at both stations are set to respond to reception of a space tone from the distant station. Traffic can now be exchanged from either station on a half-duplex basis.

#### Disconnecting a Call

2.29 During the time the two stations are connected (traffic interval), either station can initiate a disconnect as follows:

(a) A call is normally terminated by the end-of-transmission (EOT) code combination which provides fast disconnect without introducing hit characters. This is accomplished by the data set in response to EOT contact closures in function boxes of both the sending and receiving teletypewriters.

(b) A call connection can also be cleared manually by momentarily depressing the CLR pushbutton (Figure 3). Operation of the CLR pushbutton at either station will cause transmission of a spacing signal of 1.5 seconds duration, after which the station originating the disconnect will discontinue its tone transmission and go back on hook. The other station, after receiving the spacing signal for 1 second, will automatically transmit its 1.5-second spacing signal and then go on hook. Both stations will then be back in their original idle condition in which calls can be either originated or accepted.

#### Answering a Call

2.30 To answer a call manually, momentarily depress the ANS pushbutton (Figure 3). This connects the station to the line and lights the ANS lamp. The lamp remains lighted until the answer mode is terminated. Manual answering is necessary only when the automatic answer-back circuit is disabled. The automatic answer-back circuit is disabled by low-paper contacts, data set relay contacts (when in local mode), and the OUT OF SERV. key.

2.31 Call control units equipped with automatic answering facilities will respond to received ringing signals, turning the teletypewriter on at the end of the ringing interval and proceeding through to the connect condition. Automatic message answer-back is a part of this feature. The presence of an operator is required in order to complete disconnect and return the teletypewriter to idle condition. For unattended service, an automatic disconnect timing device (optional) actuated when a call is answered, will cause the teletypewriter to go through the connect condition, send the 1.5-second spacing tone, and go back on hook if the F1 mark tone is not received within 8 seconds after the called station answered. This is designed to prevent the unattended station from being made busy by (telephone) calls that fail to cause a full connection to be set up. This feature does not affect normal automatic disconnect upon receiving the 1-second spacing tone or loss of tones due to a dropoff.



## SECTION 574-123-100TC

### Local Mode

2.32 The local mode (LCL) provides off-line operation of the teletypewriter. The operator selects the local mode by depressing the LCL pushbutton (Figure 3). This lights the LCL lamp and operates the motor control relay (MCR) to energize the motor. The data set connects the sending circuit to the receiving circuit and enables the keyboard and answer-back to transmit. In this condition the teletypewriter can be used for preparing copy, for operator practice, or for maintenance purposes. If an incoming signal is received during this time, ringing signals are received and manual operation of the ANS pushbutton is required in order to receive the message. If the teletypewriter is in a terminal hunting group, the operator must turn the out-of-service (OUT-OF-SERV.) knob to the RESTORE position momentarily and then to NORMAL.

### OUT OF SERV. Switch

2.33 The OUT OF SERV. switch (Figure 3) prevents the automatic answering of incoming calls. In its NORMAL position (arrow on knob upright), it has no effect or function; in the OUT OF SERV. position (knob rotated counterclockwise and detented) it sets the following conditions:

- (a) A contact is closed that causes the OUT OF SERV. lamp to light.
- (b) A contact is closed that shorts the ringer coils. This makes the ringer inoperative. As an option the contact can be located to shunt both the ringer and series capacitor (ie, the telephone line). This makes the station appear to be in an off-hook condition or busy to the central office.
- (c) A contact is opened that breaks the automatic answer circuit to the answer relay. This prevents the relay from operating in response to the ring-up relay and thus the teletypewriter will not answer.

2.34 For stations that are not in terminal hunting groups, the operator may return the teletypewriter to service by turning the OUT OF SERV. knob to the NORMAL position. For terminal hunting stations, however, the operator must turn the knob to the RESTORE position and hold it until a dial tone is heard. In this position:

- (a) A contact is closed that shorts the tip to ring (off-hook condition). This condition is detected by the central office which then releases the teletypewriter from lockout and applies the dial tone.
- (b) A contact is closed that completes a path from the speaker amplifier to ground. This permits the amplifier to pass the line signals (dial tone).

The OUT OF SERV. switch is then restored to NORMAL.

### Low-Paper Alarm

2.35 A low-paper alarm is provided in the teletypewriter. When a low-paper condition occurs, make contacts in the low-paper switch provide ground to the low-paper buzzer, permitting it to operate. Depressing the buzzer-release (BUZ-RLS) pushbutton (locking) in the call control unit (Figure 3) silences the buzzer and causes the BUZ-RLS lamp to light. Attempting to release the pushbutton without replenishing the paper supply will result in the buzzer operating. When the paper has been replenished, the teletypewriter is returned to normal by releasing the BUZ-RLS pushbutton.

2.36 Break contacts on the low-paper switch disable the automatic answer-back circuit. The operator can override this condition by answering manually. If the low-paper alarm occurs during a call the operator has the option of completing the call before changing the paper, or interrupting the call. To interrupt the call, the operator stops transmission by depressing the keyboard BREAK key, and then depressing the BRK-RLS pushbutton to notify the distant station of the problem. The connection is cleared by simultaneously operating the control (CTRL) and EOT keys on the keyboard. Turning the OUT OF SERV. knob to the detent position insures that the teletypewriter will not automatically answer a call while paper is being replenished.

2.37 To restore the teletypewriter to service after the paper has been inserted, depress the CLR pushbutton and return the OUT OF SERV. knob (Figure 3) to its NORMAL position. (For teletypewriters in terminal hunting groups, turn the knob to its RESTORE position and hold it there. When dial tone is heard, release the knob.) The teletypewriter is now in a normal idle operating position.

### Restrain Lamp

2.38 This high intensity restrain (REST) lamp (Figure 3) lights when a restraining signal is received from an 8-level to a 5-level converter used in transmission to 5-level TWX stations on the DDD switching plan. The lamp remains lighted until the restraining signal is removed. The purpose of this feature is to limit the sending speed from 8-level teletypewriter transmitting at 100 wpm to 5-level teletypewriters receiving at 60 wpm.

### Test Mode

2.39 If the TST pushbutton (Figure 3) is operated while the teletypewriter is connected to a test center, the message sent by the test center will be recorded on the teletypewriter and turned around and sent back for analysis. This is accomplished by connecting the teletypewriter to the data set through a set of transfer contacts and a break contact to ground. This type of operation can be terminated by momentarily operating any of the nonlocking pushbuttons which will then release the TST locking pushbutton.

**Signal Generation**

2.40 The teletypewriter can send by operating the keyboard, answer-back mechanism, or BREAK key (Figure 3). The keyboard signal generator contacts and answer-back contacts are in parallel with the signal generator (distributor) which is, in turn, connected to the data set. The BREAK key connects to the data set via separate leads.

**Dialers**

2.41 **Pulsing Rotary Dialer:** For rotary dialer applications a pulsing contact of the rotary dialer is inserted into the telephone line. The rotary dialer (Figure 3) is equipped with a normally closed pulsing contact and a normally opened off-normal contact. The pulsing contact is inserted into the telephone line when the station originates a call. When answering the call, a short circuit is applied across the pulsing contact. The off-normal contact is placed across the output of the amplifier and silences the speaker whenever the dialing disc is moved.

2.42 **Pulsing Card Dialer (40A Dialer):** The 40A dialer operates on direct current furnished from the central office. To use the card dialer, the ORIG pushbutton is depressed. After a dial tone has been received, a card with the telephone number punched in it is firmly inserted in the slot. This operation winds a spring which later pushes the card out of the slot as dialing proceeds.

2.43 The card dialer is started by momentarily depressing the START bar. This operates the card dialer start contact and establishes a path from the ring side to the tip side of the telephone line. Sending of the dial pulse means interruptions of the current in the telephone line.

2.44 A scanning drum makes sixteen revolutions, ten for transmitting the digits and six for interdigital time. At the completion of the revolutions, an escapement is tripped which permits the next row of holes on the card to be placed in position for sensing.

2.45 This sequence is repeated at each row as the card advances out of the card dialer. If no "stop" code is punched in the card, the card dialer will continue to advance the card (even if no number code is punched) until the card is released. If the "stop" code is sensed, the card dialer stop contacts operate. The card can be released by operating the RELEASE bar. No attempt should be made to release the card by reoperating the START bar, as this will trigger the card dialer mechanism and place a short circuit across the output of the data set. This shunt will prevent the station from receiving or sending until the card is disengaged. If this condition persists, the data set will disconnect.

2.46 **Pulsing Card Dialer (41A Dialer):** In locations with 60-hertz ac power the 41A card dialer is used. In this dialer the power to operate the commutator disc is

derived from a synchronous motor powered by the 14 v ac source in the teletypewriter. The power to advance the card in the dialer is derived from a spring wound by inserting the card in the slot. The switching functions and the motor control are independent of the signal path. These features result in a superior performance as compared with the 40A dialer.

2.47 To operate the dialer, the card is inserted and the START bar is momentarily operated. The commutator disc begins rotating, and the dial pulses are sent to the line.

2.48 When all the punched codes are sent the disc stops. A mechanical linkage then permits the spring, wound by inserting the card, to advance the card for the next digit to be read and dialed. As the "stop" code is read, the dialing stops. The card can then (as also at any other time) be released by operating the RELEASE bar.

2.49 **TOUCH-TONE Dialer:** For multifrequency (MF) dialing applications, the dialing frequencies generated by the TOUCH-TONE dialer are fed through the loudspeaker amplifier and into the telephone line via the sending amplifier in the data set. As the station connects, the output of the TOUCH-TONE dialer is disconnected from the data set so that there is no hazard connected with improper operation of the TOUCH-TONE dialer at that time.

2.50 The TOUCH-TONE MF signal generated is a 1-transistor oscillator generating two frequencies any time a single pushbutton is operated. Seven frequencies are provided, with each dial digit corresponding to two frequencies according to the table below:

**TOUCH-TONE**

**Frequencies**

cps	1209	1336	1477	
697	1	2	3	Dial Digits
770	4	5	6	
851	7	8	9	
941		10		

2.51 The frequencies above 1000 hertz are generated at a somewhat higher level to compensate for greater line loss at those frequencies. There is also a variation or amplitude for various digits.

2.52 TOUCH-TONE and Card Dialer (Figure 3): To use the automatic card dialer, the ORIG pushbutton is depressed. After the dial tone has been received, a punched card is inserted into the slot and pushed down. The START bar is then momentarily operated. The card dialer proceeds with dialing under power of a spring motor wound by insertion of the card. When a "stop" code is read, the dialing stops. The card should then be released by reoperating the START bar.

2.53 The sensing contacts in the card dialer are in parallel with the frequency-determining contacts in the associated TOUCH-TONE dialer. As the card advances out of the slot, the sensing contacts sense the holes punched in the card and thus determine the proper frequencies to be transmitted. This occurs for every row on the card.

2.54 Since the card advances out of the slot very rapidly, there is no need for a separate RELEASE bar. When the station connects, relay contacts in the data set disconnect the MF signal input and remove any hazard connected with false operation of the TOUCH-TONE dialer.

Fuse Protection

2.55 Three fuses protect the components in the call control unit from accidental shorts or overloads. The selector magnet driver fuse is 0.5 amp slow blowing; the motor delay timer fuse is 2.25 amp slow blowing; the ac line fuse is 3.2 amp, slow blowing.

Electrical Interconnections

2.56 A number of nylon plugs and a terminal strip located at the rear serve to interconnect the set components to the call control unit. A six foot power cord connects the call control unit to the ac power source.

Circuits

2.57 Selector Magnet Driver Circuits: The data set supplies a 20-ma dc signal to the selector magnet driver associated with the teletypewriter. The selector magnet driver amplifies the signal to 500ma to operate the selector on the teletypewriter. The selector magnet driver is a two-stage triggering regenerative amplifier (or flip-flop) capable of switching high output currents of 0.500 ampere at very closely controlled input current levels. The output of the selector magnet driver is automatically regulated and is essentially independent of normal variations in power supply voltage, and of selector-magnet and current-limiting resistance values.

2.58 Speaker Amplifier Circuit: The speaker amplifier is powered only after the ORIG key is operated and is quieted when the Station connects. It has two inputs, one from the telephone line via the buffer amplifier in the data

set limiter and the other from the multifrequency (MF) tone dialer. Three outputs are provided: (1) into the speaker or optional hand-held receiver; (2) into the telephone line through the sending amplifier in the data set; and (3) an auxiliary output into the data set. The line-to-speaker connection permits monitoring of supervisory signals when originating a call. The TOUCH-TONE dial-to-line and TOUCH-TONE dial-to-speaker connection provides for amplification of the outgoing MF dialing signals and for monitoring them during outpulsing. The line-to-second-output connection is provided for the dial tone detector (when furnished). The various connections mentioned are established by switching in the data set and by the common switch in the TOUCH-TONE dialer.

2.59 Technical Data

Dimensions (Approximate)

Width . . . . . 5 inches  
 Length . . . . . 17 inches  
 Height . . . . . 6 inches

Input . . . . . 117 v ac + 10%, 60Hz  
 Environmental conditions . . . . . 40° F to 110° F  
 ambient temperature

CALL CONTROL UNIT FOR PRIVATE WIRE SERVICE (Figure 4)

2.60 Power for the motor, selector magnet driver, local power supply, and tape reader power pack, is supplied from fused 117 volt ac, 50 to 60 hertz power. Direct current of either 0.020 or 0.060 ampere is required for the signal line(s) and for operation in the local mode. The dc power for the signal line(s) is supplied by external facilities, while local dc current for operation in the local mode is furnished through the operation of the local power supply circuit in the call control unit. At the rear of the call control unit is a terminal strip which provides the point of entry for the ac power and the signal line(s) into the teletypewriter set.

2.61 A 3-position rotary power switch is the only manual control on the call control unit. Its three positions are: OFF, LOCAL, and LINE.

Fuse Protection

2.62 Two fuses protect the components in the call control unit from accidental shorts and overloads. The selector magnet driver fuse is 0.8 amp, slow blowing; the ac power line fuse is 2.8 amp, slowing blowing.

Electrical Interconnections

2.63 Connector plugs at the rear of the call control unit serve to interconnect the set components to the call control unit. A terminal strip, also located at the rear,

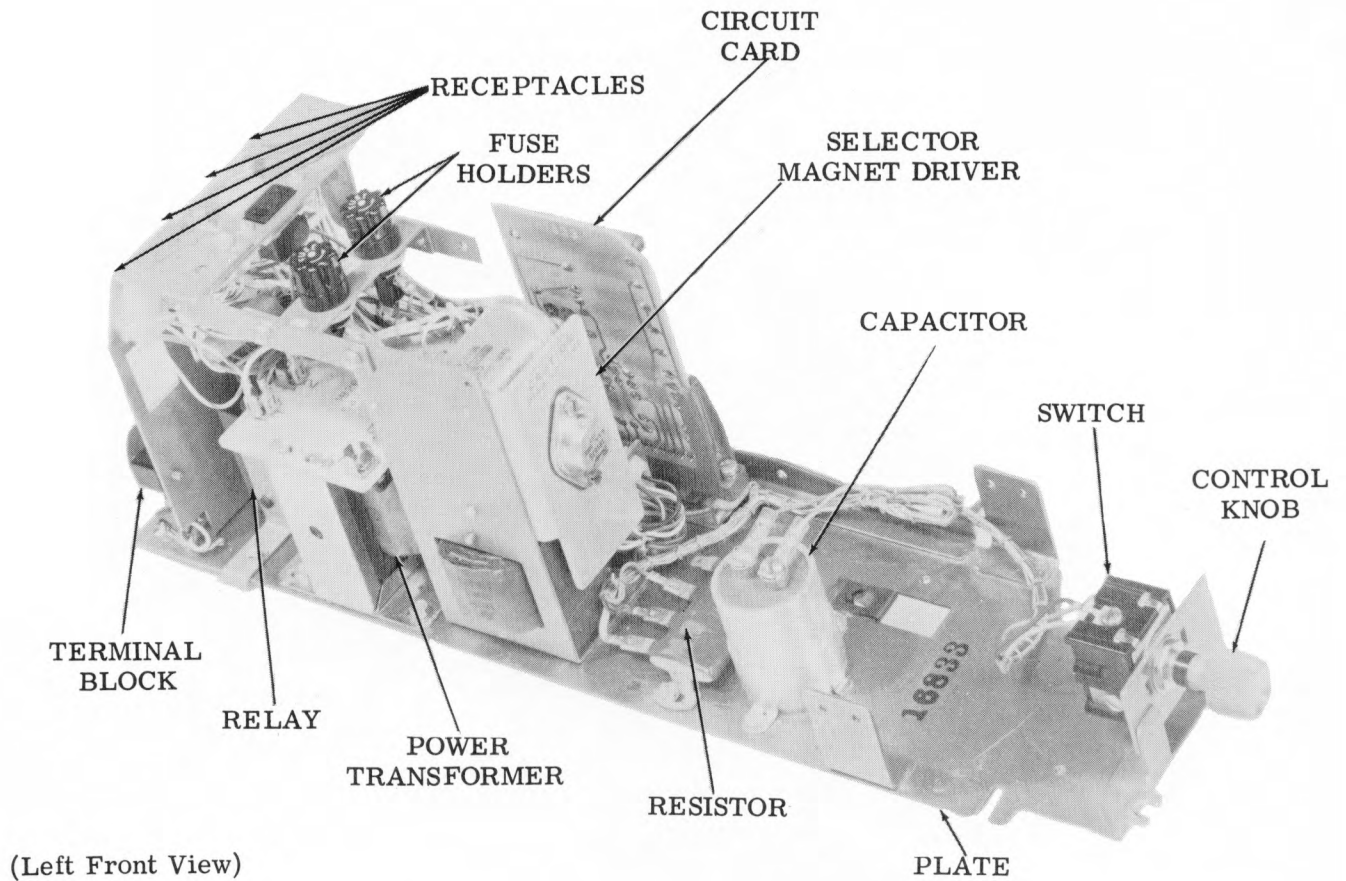

Figure 4 - Call Control Unit for Private Wire Service

serves to connect the ac power to the call control unit and offers a convenient terminating area for other accessories and external connections.

Line Mode

2.64 When the switch is in the LINE position, the teletypewriter can be placed in the external signal line loop for communication with other teletypewriters. The external signal line loop is united with the selector magnet driver. With dc power on the signal line, and transmission from the keyboard or tape reader will cause the typing distributor to send start-stop signals to other teletypewriters in the external signal loop. Also, the local teletypewriter is able to receive, through the typing unit selector, the start-stop signals transmitted from other teletypewriters in the signal line loop.

Local Mode

2.65 When the switch is in the LOCAL position, (1) the local battery is supplied to the selector magnet driver and the send circuit, (2) the external signal line loop is

divorced from the selector magnet driver, and (3) the external signal line loop is shunted so that other teletypewriters in that loop can communicate without being affected by the operation of the local teletypewriter.

Off Mode

2.66 When the switch is in the OFF position, the signal line is diverted around the local teletypewriter. Other teletypewriters can communicate in the signal loop without interference. All power in the call control unit, except the ac power to the selector magnet driver, is off.

2.67 Technical Data

Dimensions (Approximate)

Length . . . . .	.15 inches
Width . . . . .	4 ½ inches
Height . . . . .	6 inches

Input . . . . .	.117 v ac, 50-60 Hz
Environmental conditions . . . . .	40° F to 110° F ambient temperature



**33 TAPE READER**  
**GENERAL DESCRIPTION AND**  
**PRINCIPLES OF OPERATION**

	CONTENTS	PAGE	
1.	GENERAL .....	1	<b>1. GENERAL</b>
2.	DESCRIPTION .....	1	1.01 This section is reissued to provide exclusive coverage for the 33 tape reader. Information about the 32 tape reader formerly presented with the 33 tape reader has been omitted and is covered in a separate section. A general updating of the 33 tape reader is being presented in this section so that marginal arrows ordinarily used to indicate changes have been omitted.
	TECHNICAL DATA .....	1	1.02 The 33 tape reader is an 8-level electro-mechanical device which senses and transmits coded intelligence perforated in tape (Figure 1).
3.	PRINCIPLES OF OPERATION .....	2	1.03 References to left, right, front, rear, consider the tape reader as viewed by the operator.
	OUTLINE OF OPERATION .....	2	1.04 In the illustrations, fixed pivots are solid black, and floating points — those mounted on parts that move — are crosshatched.
	DETAILED OPERATION .....	3	<b>2. DESCRIPTION</b>
	A. Tape Lid Mechanism .....	3	<b>TECHNICAL DATA</b>
	B. Control Mechanism .....	3	2.01 Dimensions and Weight (Approximate)
	C. Distributor Trip Mechanism .....	5	Feeding and Sensing Component
	D. Feed Magnet Mechanism .....	6	Width .....
	E. Sensing Pin Guide Mechanism .....	6	Depth .....
	F. Contact Block Mechanism .....	7	Height .....
	G. Tape Feed Mechanism .....	9	Weight .....
	H. Upstop Mechanism .....	10	Power Pack Component
4.	FEATURES .....	10	Width .....
	STANDARD FEATURES .....	10	Depth .....
	A. Freewheeling Mechanism .....	10	Height .....
	B. Tight-Tape Mechanism .....	10	Weight .....
	C. Tape-Out Mechanism .....	10	
	AUTOMATIC CONTROL FEATURES .....	12	
	A. Local Start .....	12	
	B. Remote Start .....	12	
	C. Reader Stop .....	12	
	D. FREE Position .....	15	

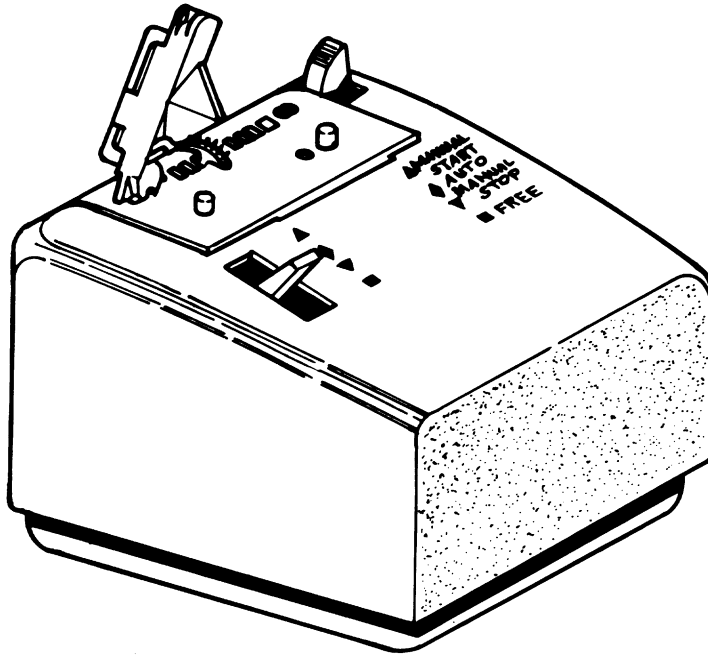

(Left Front View)

Figure 1 - 33 Tape Reader with Automatic Features

2.02 Electrical — Power Pack

High Voltage:

Input . . . . . 115 volts ac  
 Output . . . . . Min 137 volts dc  
 @ 0.160 ampere

2.03 Feed Magnet

Power dissipation . . . . . 2-1/4 watts  
 Nominal attraction time. . . . . 8 to 11 milli-  
 seconds at a nominal peak transient  
 current of 0.220 ampere  
 Nominal release time . . . . . 7 to 10 milli-  
 seconds

**CAUTION: HIGH VOLTAGE PERSISTS 10  
 SECONDS AFTER POWER IS REMOVED.**

2.04 Speed . . . . . 100 words per minute

2.05 Tape Specifications

Level . . . . . 8-level  
 Width . . . . . 1 inch  
 Code combinations per inch . . . . . 10  
 Feed hole diameter . . . . . 0.0465 inch

2.06 Signal Characteristics

Long telegraph loops . . . . . 0.015 to 0.070  
 ampere at 48  
 to 240 volts dc inductive  
 Short telegraph loops . . . . . 0.058 to 0.072  
 ampere at 16  
 to 22 volts dc resistive

3. PRINCIPLES OF OPERATION

OUTLINE OF OPERATION

3.01 The tape reader senses coded intelligence perforated in tape and transmits this intelligence as a parallel output.

3.02 The tape reader package consists of three mechanisms; the reader mechanism, the power pack, and the distributor trip mechanism (Figure 2).

3.03 The reader mechanism senses and feeds the tape. Other submechanisms within the reader mechanism transmit the intelligence as a parallel output. The reader mechanism mounts on the left side of the typing unit.

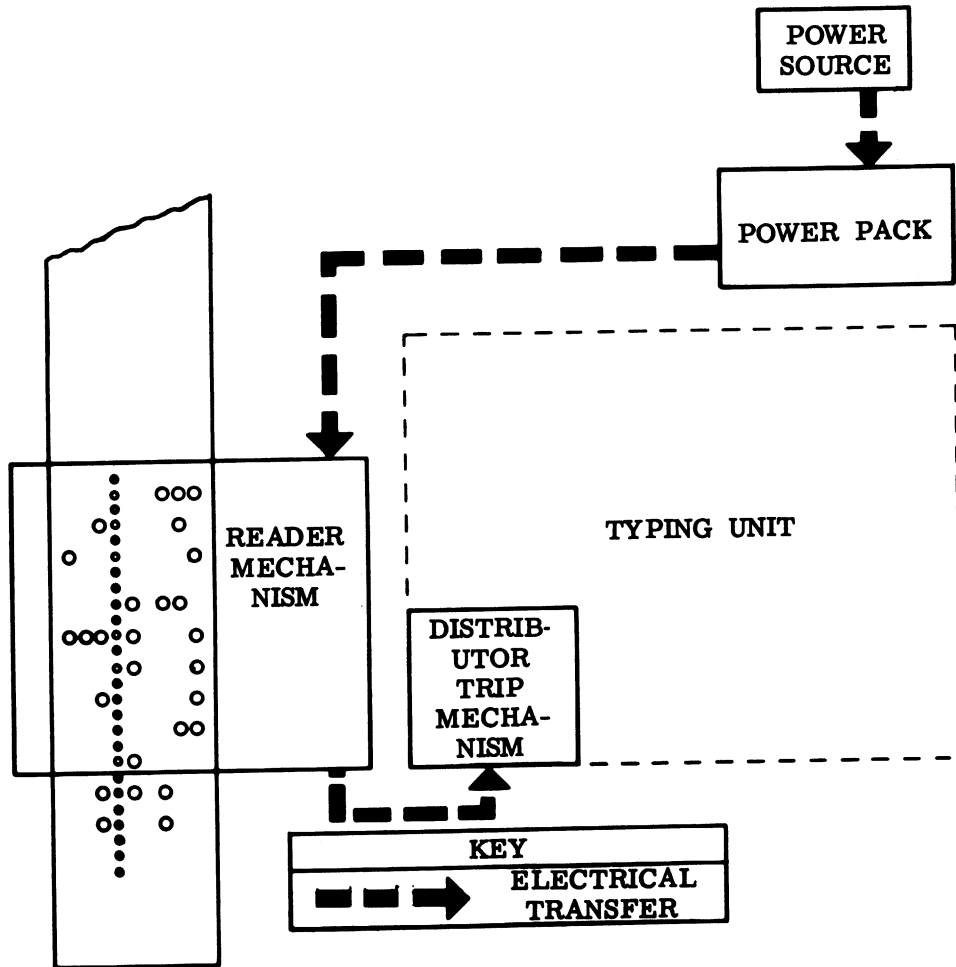

Figure 2 - Tape Reader Package with Major Mechanisms

3.04 The power pack provides current rectification for the reader mechanism. It mounts at the rear of the Teletypewriter Set underneath the typing unit base.

3.05 The distributor trip mechanism receives the reader mechanism output and converts it into serial start-stop signals.

#### DETAILED OPERATION

##### A. Tape Lid Mechanism

3.06 When the tape lid latch handle is moved to the right, the spring biased tape lid swings open. Two locating pins guide the tape as it travels above the top of the plate (Figure 3).

##### B. Control Mechanism

3.07 In the standard reader there are three positions for the control lever: START, STOP, and FREE. In the automatic reader there are four positions for the control lever: MANUAL START, AUTO, MANUAL STOP, and FREE. When the control lever is moved to the START position (MANUAL START position for the automatic reader — Figure 4) the spring biased start contact wires are positioned on the start contact. Since the start contact wires and the start contact are wired in series with the distributor clutch trip coil in the typing unit, the coil energizes and releases the tape reader trip lever (Figure 5).



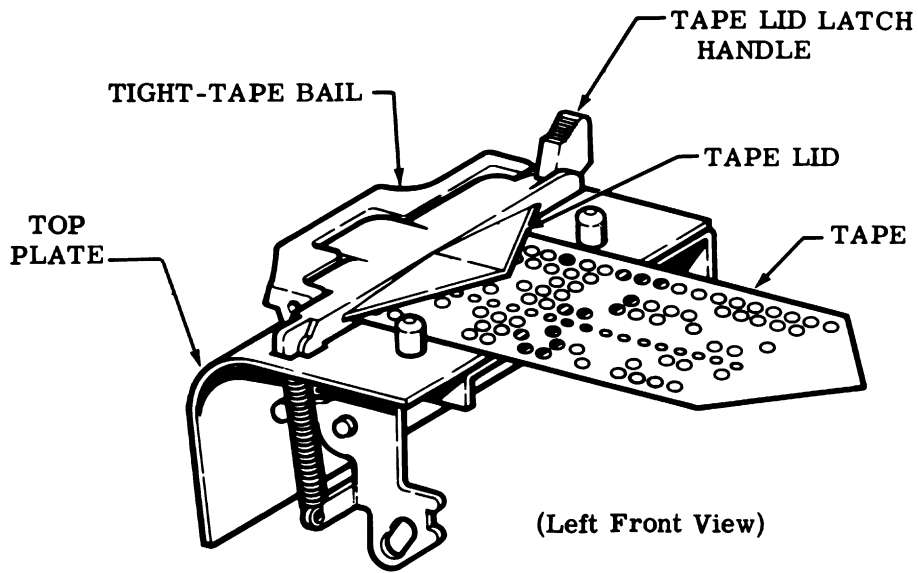

Figure 3 - Tape Lid Mechanism

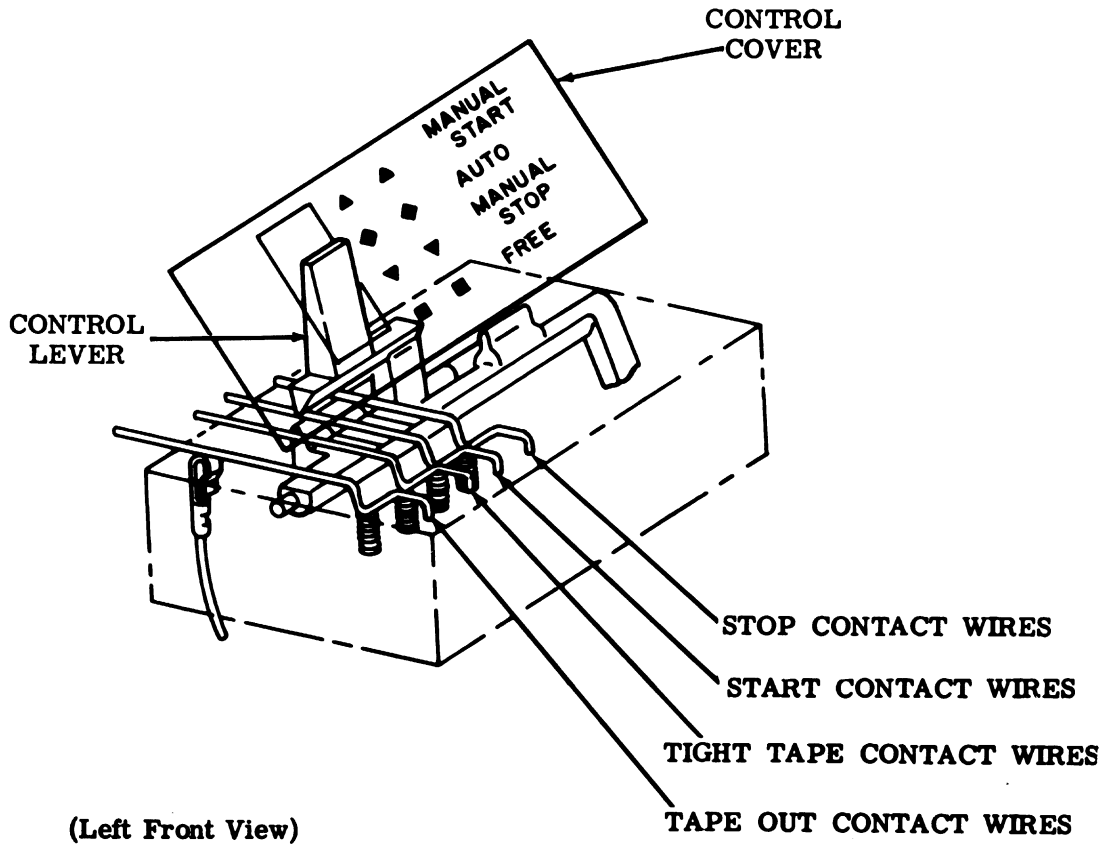

Figure 4 - Control Mechanism

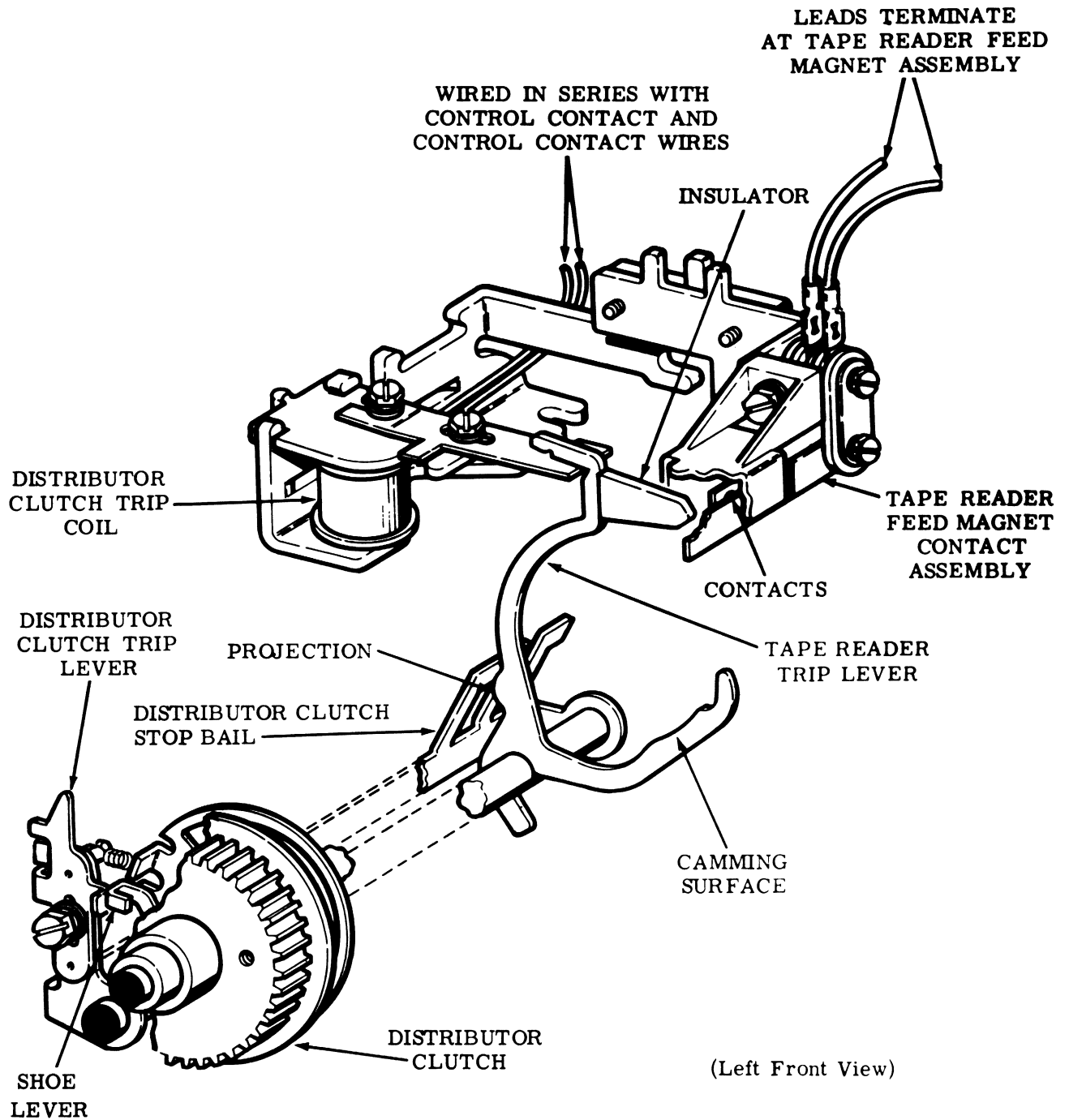

Figure 5 - Distributor Trip Mechanism

C. Distributor Trip Mechanism

3.08 When released the tape reader trip lever performs two functions; it closes the tape reader feed magnet contact assembly and trips the distributor clutch (Figure 5). The reader feed magnet assembly is closed by an insulator

on the back of the tape reader trip lever. In its travel, the tape reader trip lever rotates the distributor clutch stop bail by means of a projection. This motion is transferred to the distributor clutch trip lever which moves away from the shoe lever. The distributor clutch engages and the distributor cycle begins.

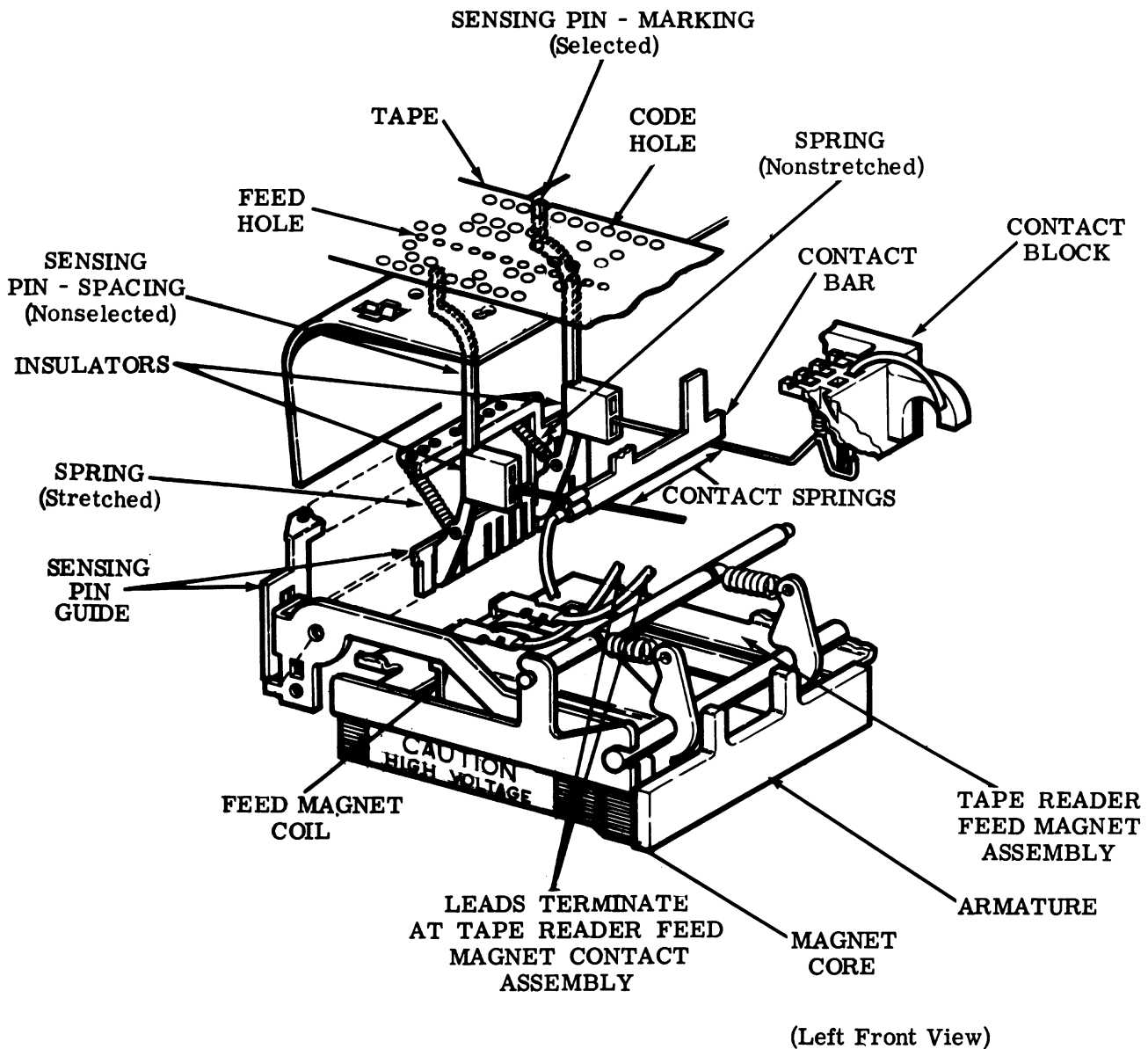

Figure 6 - Feed Magnet and Sensing Mechanism

**D. Feed Magnet Mechanism**

3.09 With the feed magnet contacts closed (Figure 5) the feed magnet in the reader mechanism is activated. The energized feed magnet coil attracts the armature (Figure 6). Rotating about its pivot the armature raises the armature extensions. Fastened to the ends of the armature extensions is a sensing pin guide.

**E. Sensing Pin Guide Mechanism**

3.10 In its upward travel the sensing pin guide carries with it eight spring-biased pins which sense the tape. Where a hole exists in the tape (marking) the sensing pin continues its upward travel and its associated spring remains unstretched. Where no hole exists in the tape (spacing) the sensing pin travel is blocked and its associated spring becomes stretched (Figure 6).

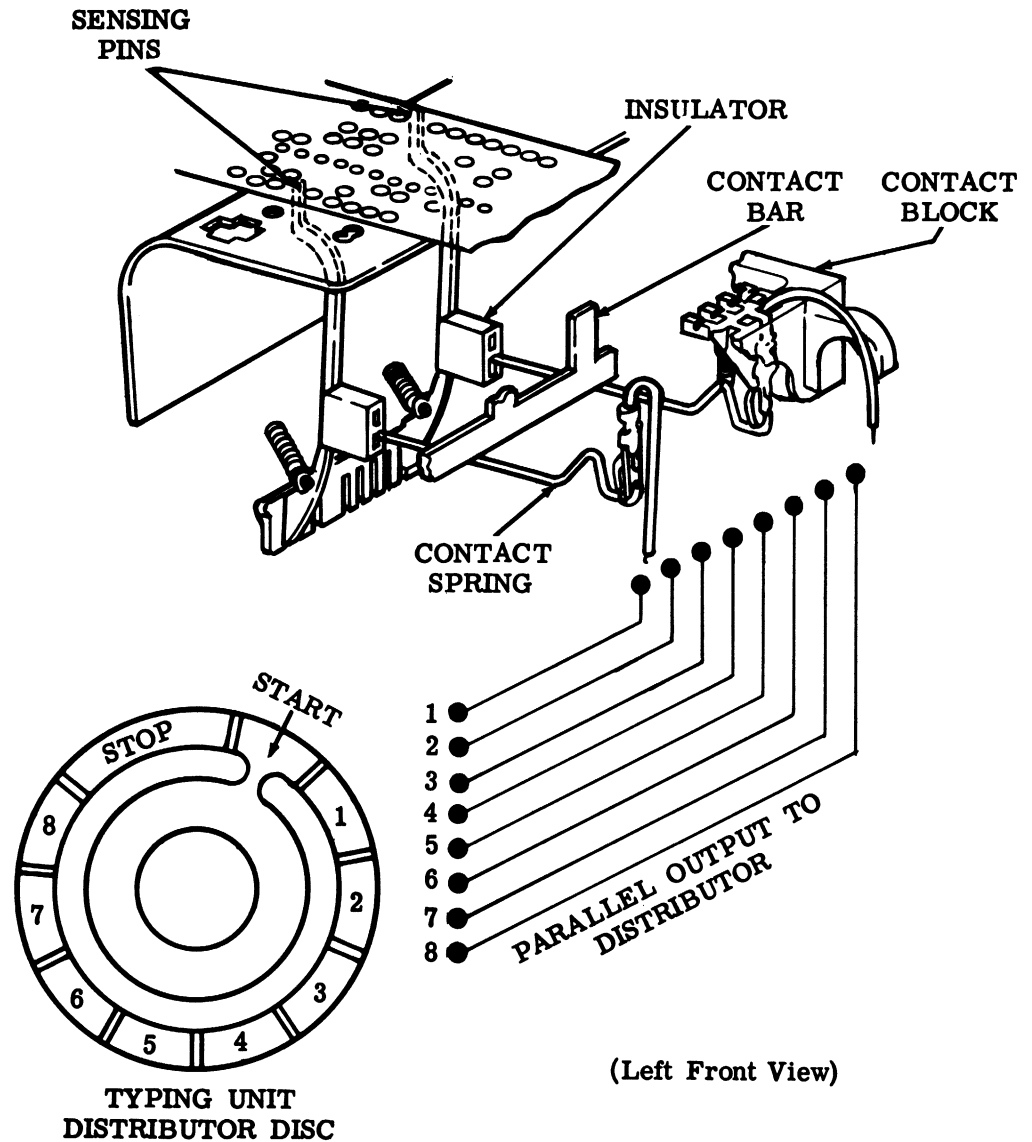
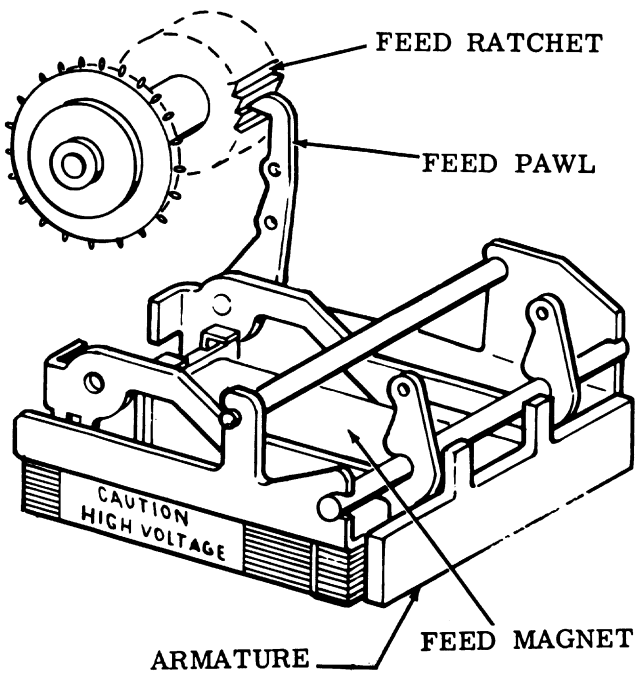

Figure 7 - Contact Block Mechanism

#### F. Contact Block Mechanism

3.11 There is an insulator attached to each sensing pin. The insulators hold eight contact springs in a down position, away from the contact bar (Figure 7). The eight contact springs are connected in parallel to corresponding segments on the distributor disc in the typing unit. If a sensing pin finds a hole in the tape (marking) it continues its upward travel. The

insulator attached to it also rises, allowing the contact spring to make contact with the contact bar (Figure 7). If a sensing pin does not find a hole in the tape (spacing) it remains in the down position, keeping the insulator down. This prevents the contact spring from making contact with the contact bar. Since all eight pins rise up simultaneously, the output going from the contact block to the distributor disc will be a parallel output.



(Left Front View)

Figure 8 - Feed Pawl Engagement

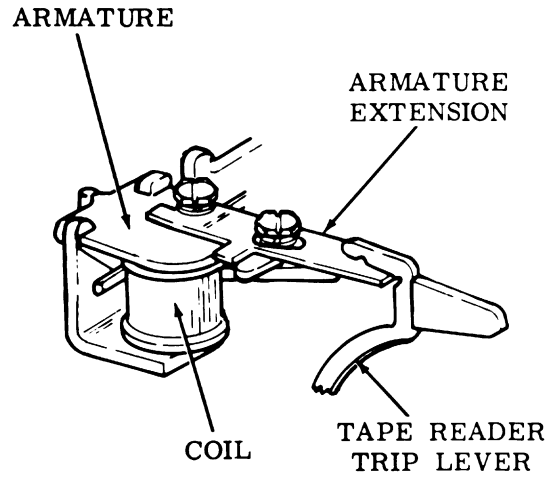

(Left Front View)

Figure 9 - Distributor Clutch Trip Coil

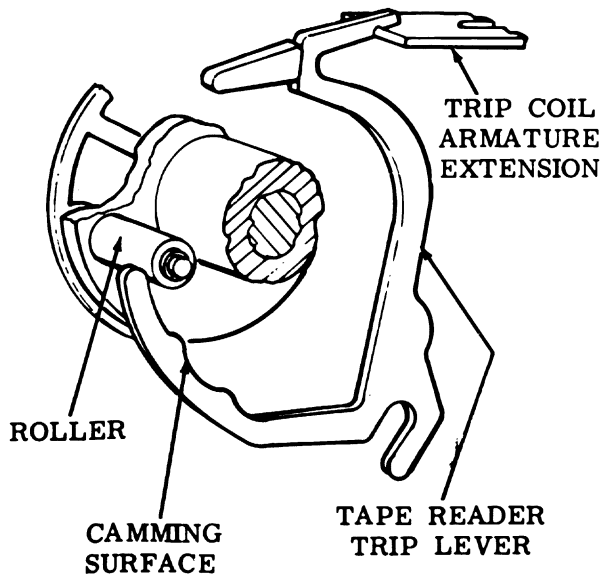

(Right Side View)

Figure 10 - Tape Reader Trip Lever

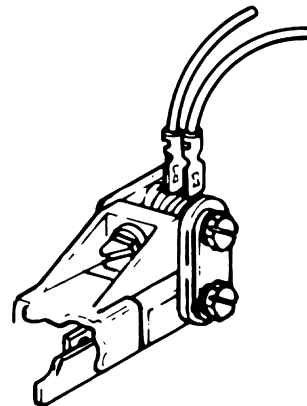

Figure 11 - Feed Magnet Contacts

### G. Tape Feed Mechanism

3.12 The tape feeding cycle begins when the feed magnet attracts the armature as described in 3.09. The right armature extension has a feed pawl attached to it which engages a tooth on the feed ratchet when the armature extensions rise (Figure 8). Before the feed pawl can be pulled down to advance the feed wheel one character a series of steps take place as follows.

3.13 If the control lever is held in the START position, the distributor clutch trip coil will remain energized (Figure 9).

3.14 Near the beginning of the stop pulse the camming surface on the reader trip lever rides the camming roller on the distributor shaft and overtravels the trip coil armature (Figure 10).

3.15 The feed magnet contacts open momentarily causing the feed magnet in the reader mechanism to be de-energized (Figure 11).

3.16 With the feed magnet de-energized the armature extensions drop, withdrawing the sensing pin guide and the sensing pins (Figure 12).

3.17 The tape reader trip lever is reset in sufficient time so that the distributor clutch does not disengage. The tape reader trip lever, once reset, closes the feed magnet contacts by means of the insulator. The projection moves the distributor clutch stop bail which in turn keeps the distributor clutch trip lever away from the shoe lever, allowing the clutch to continue its rotation.

3.18 Tape feeding will occur at the same time that the sensing pins are withdrawn. As the armature extensions drop down the pawl advances the feed ratchet one tooth (Figure 13). Associated with the feed ratchet are also a detent lever and a blocking pawl.

3.19 The detent lever, with its circular surface engaging the feed ratchet teeth, holds the feed ratchet and the feed wheel in its correct position during sensing (Figure 13).

3.20 The blocking pawl, which rides a post on the feed pawl, is lowered into engagement with a feed ratchet tooth during the feed stroke. This is to prevent excessive overthrow of the feed wheel during feeding, without the use of a

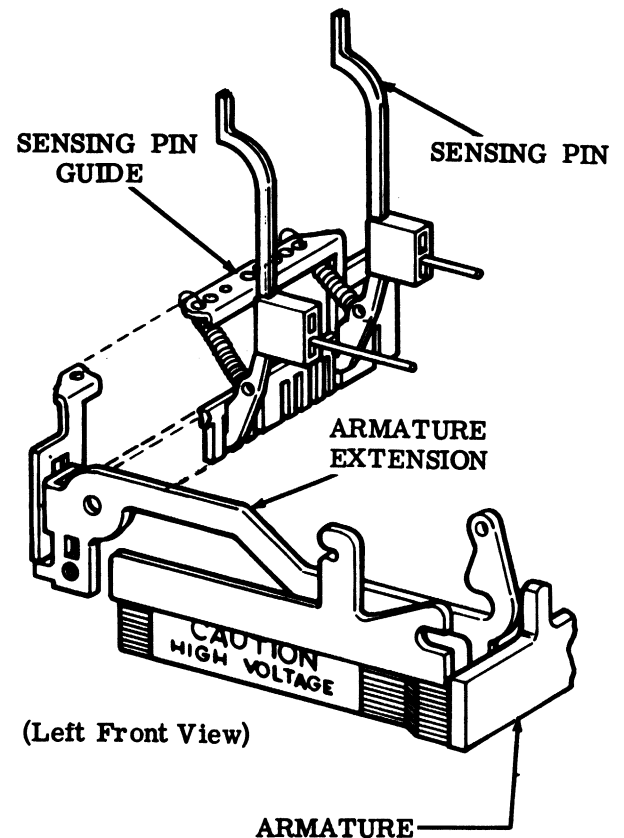

Figure 12 - Sensing Pin Guide

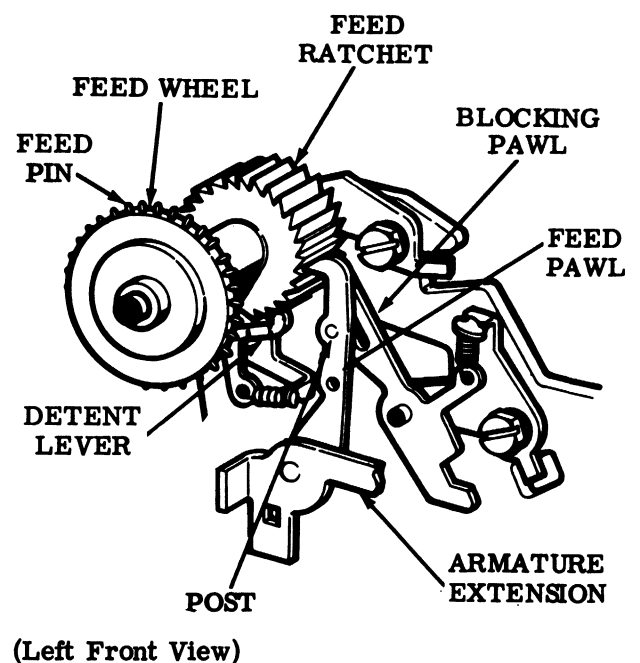

Figure 13 - Tape Feed Mechanism

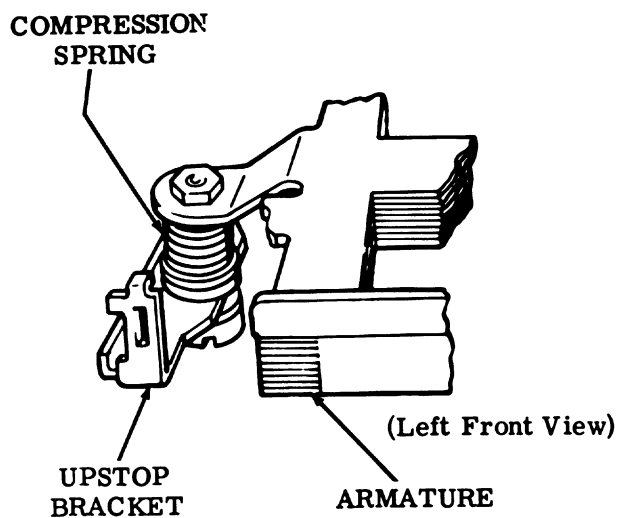

Figure 14 - Upstop Mechanism

heavy detent spring. It also prevents the pulling ahead of the tape, during sensing, by a tape winder, without the use of a heavy detent spring. During the upstroke of the armature extensions, the blocking pawl is rotated out of engagement with the tooth by the post on the feed pawl (Figure 13).

#### H. Upstop Mechanism

3.21 The armature is provided with a spring biased upstop which serves two purposes.

- (a) A portion of the energy during the end of the stroke is stored in a spring and returned to the armature on the downstroke to give a rapid release and acceleration.
- (b) A portion of the energy is dissipated through a resilient buffer to minimize noise and metallic clatter (Figure 14).

### 4. FEATURES

#### STANDARD FEATURES

##### A. Freewheeling Mechanism (Figure 15)

4.01 The 33 tape reader is provided with a freewheeling feature which allows the feed wheel to rotate freely. When the control lever is moved to the FREE position, the extension on the control lever engages the blocking pawl and pivots it clockwise. Riding in a slot on the underside of the blocking pawl is a stud which connects to the feed pawl. As the blocking pawl

is pivoted clockwise by the control lever extension, the blocking pawl moves the feed pawl away from the feed ratchet. With the feed ratchet free, the feed wheel will also rotate freely.

##### B. Tight-Tape Mechanism (Figure 16)

4.02 This feature consists of a plastic tight-tape bail which snaps into the tape lid. The tight-tape bail serves to turn the tape reader OFF when the moving tape becomes taut. The tight-tape bail has an extension on it which projects through the top plate. This extension rides on a spring biased tight-tape lever. If the tape in the tape reader becomes taut, the bail will be lifted. The bail extension will rotate, causing the tight-tape lever to rotate also. In its pivoting motion the tight-tape lever will lift the tight-tape contact wires away from the contact terminal, breaking the current path. With the circuit broken the tape reader stops.

##### C. Tape-Out Mechanism (Figure 17)

4.03 The tape reader is equipped with a tape-out feature which will stop the tape reader when the tape runs out. A tape-out pin protrudes above the surface of the top plate. During tape sensing the tape-out pin is kept depressed by the moving tape. When the tape runs out, the spring biased tape-out pin moves fully up. An

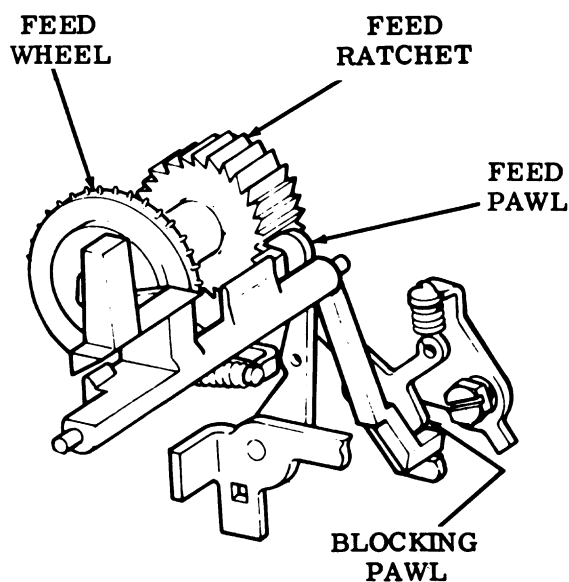

(Left Front View)

Figure 15 - Freewheeling Mechanism

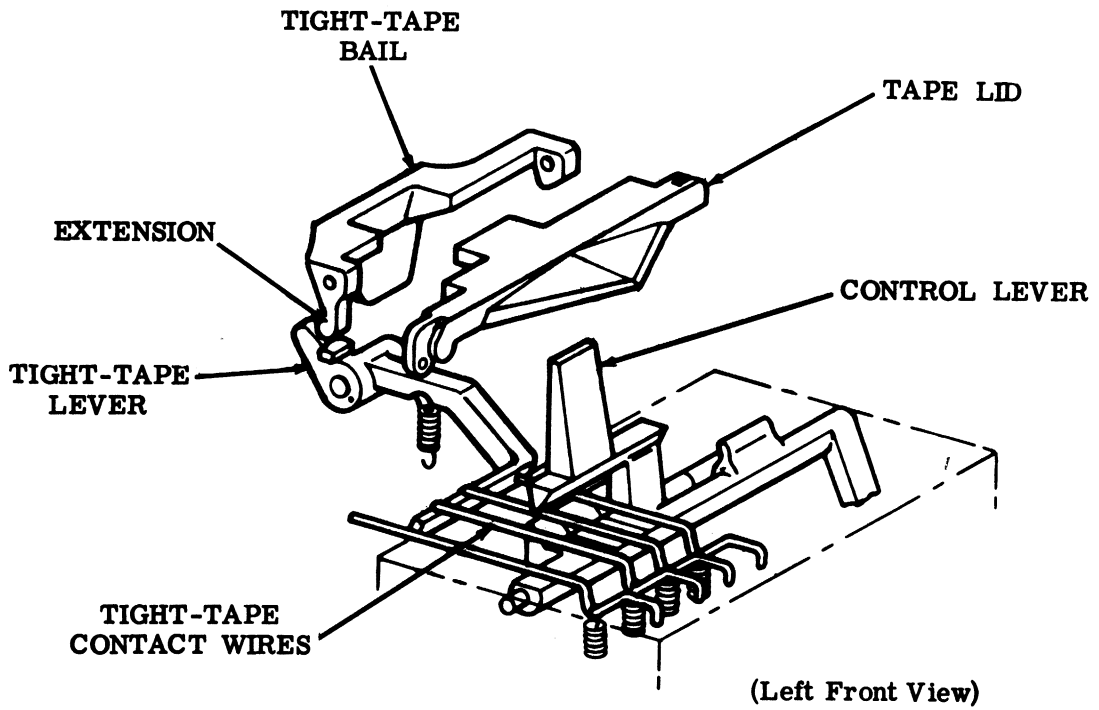

Figure 16 - Tight-Tape Mechanism

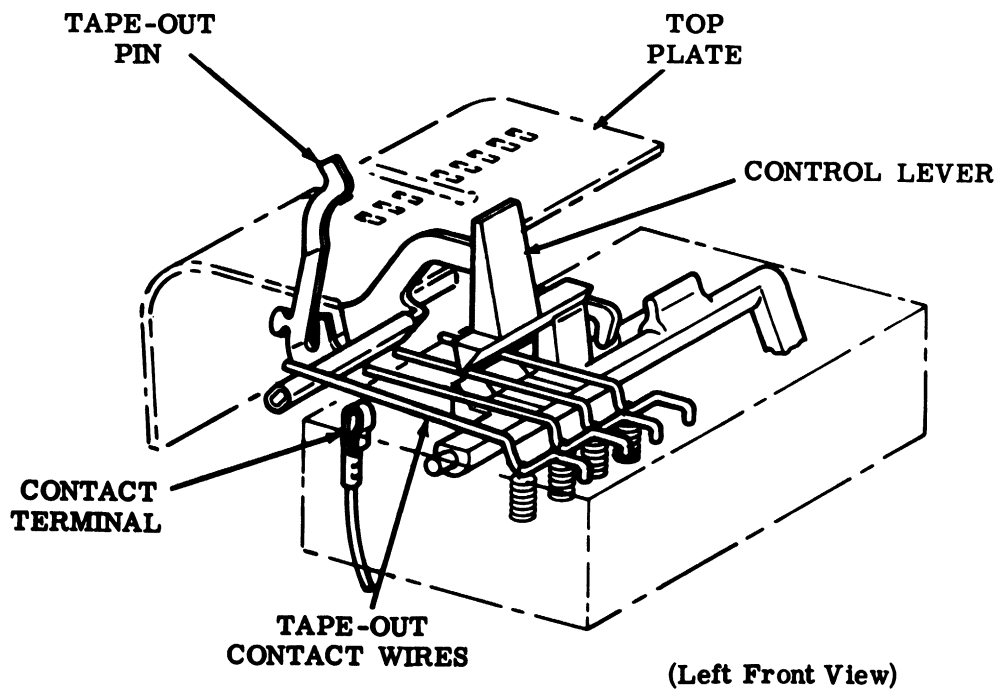

Figure 17 - Tape-Out mechanism



## SECTION 574-124-100TC

insulated extension on the tape-out pin lifts the tape-out contact wires away from the contact terminal. This breaks the current path and the tape reader stops.

### AUTOMATIC CONTROL FEATURES

4.04 The automatic control features allow the tape reader to be started or stopped either manually or automatically. This is accomplished by means of additional contacts, a relay, and wiring. There are other contacts in the typing unit function area and, for sprocket feed typing units, in the form out mechanism, which are related with the tape reader automatic features.

#### A. Local Start (Figure 18)

4.05 When the control lever is placed in the MANUAL START position the following events take place:

- (a) The start contact wires close momentarily.
- (b) After closing momentarily the start contact wires are opened due to the detent action of the control lever.

(c) The momentary closing of the start contact wires energizes the relay and two normally open contacts associated with the relay.

(d) The first relay contact closes a holding circuit.

(e) The second relay contact — if there is tape in the tape reader and the tape-out contact is closed — closes the circuit to the distributor clutch. The distributor clutch will then be tripped as explained in 3.08.

#### B. Remote Start (Figure 19)

4.06 When the control lever is placed in the AUTO position, the start contact is open and the stop contact is closed. The tape reader will respond to a remote reader start signal and turn ON automatically. The remote signal will close a contact in the typing unit function area and complete an electrical path to the distributor area.

#### C. Reader Stop

4.07 When the control lever is placed in the MANUAL STOP position, the stop contact wires are momentarily opened, de-energizing

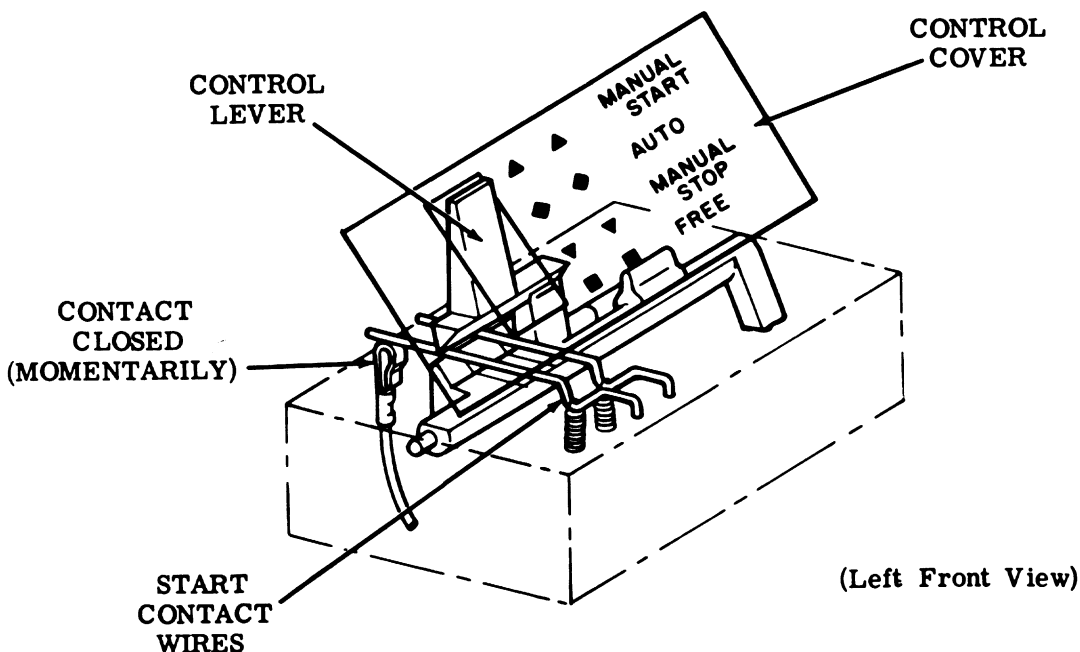

Figure 18 - MANUAL START Position

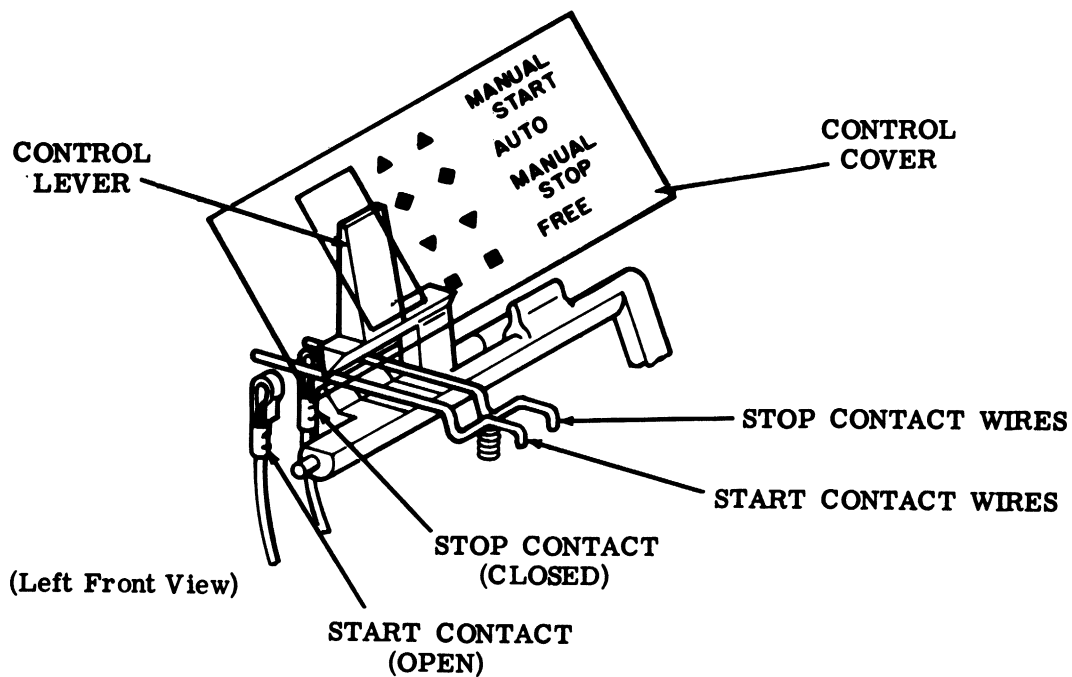

Figure 19 - Automatic Start Position

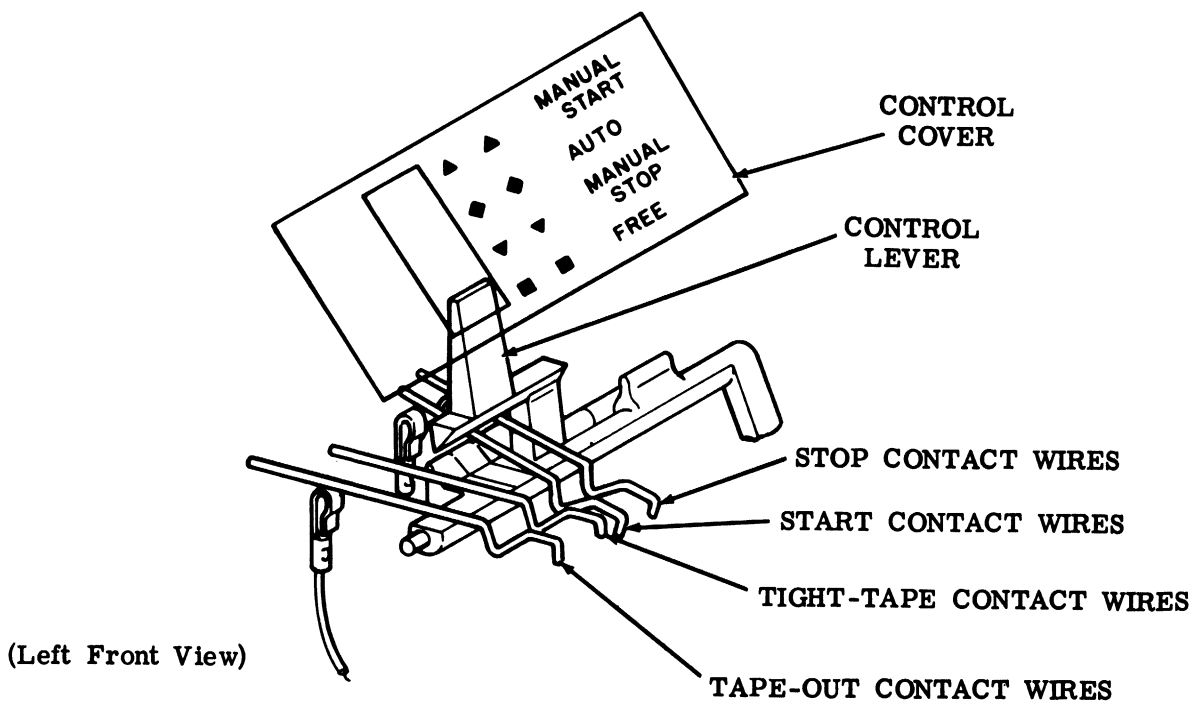

Figure 20 - Control Lever in FREE Position

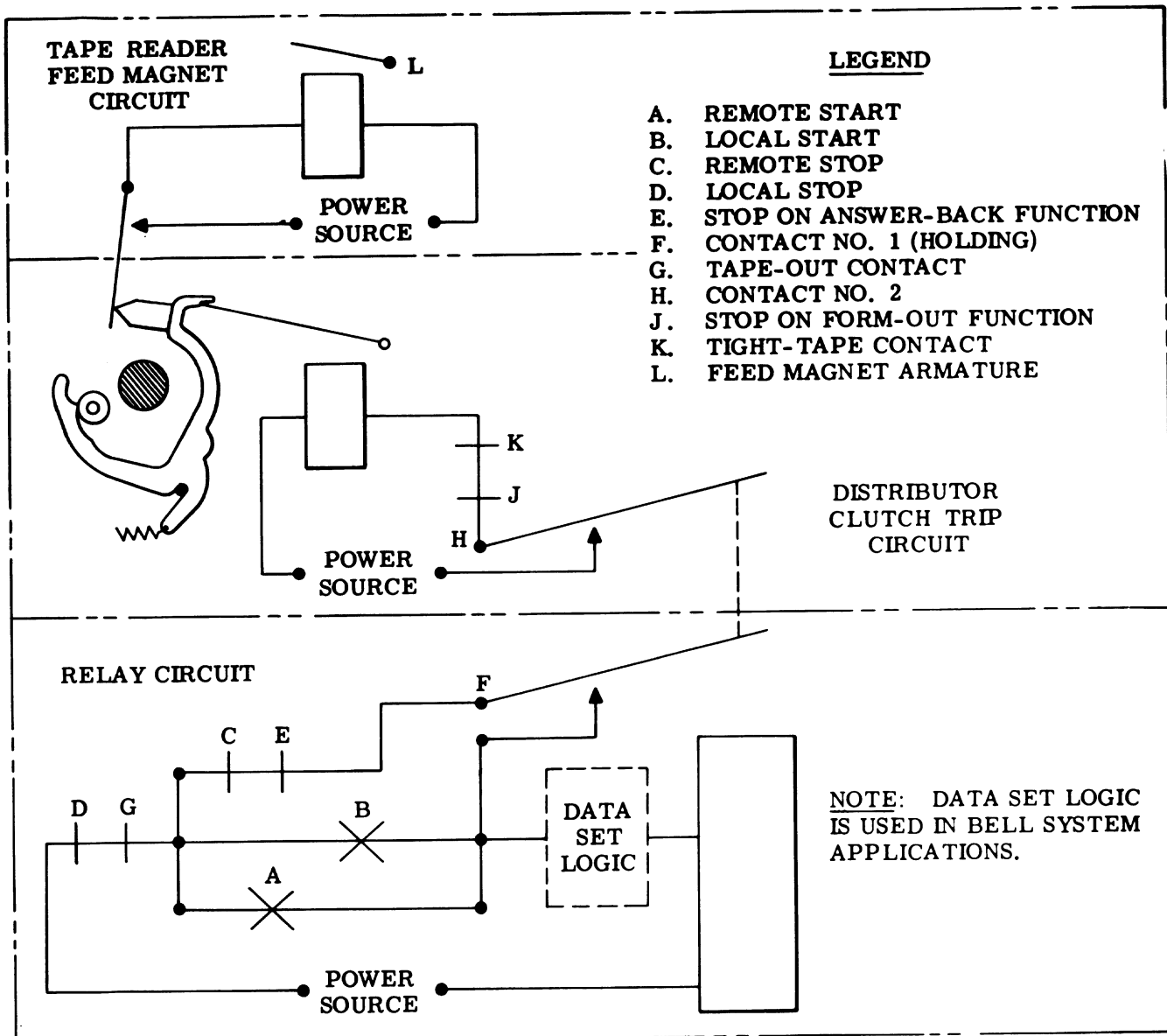

Figure 21 - Automatic Reader Control Schematic

the relay and opening two relay contacts. One of these contacts opens the reader trip magnet circuit. The trip magnet de-energizes causing the tape reader to stop.

**Alternate Reader Stop**

4.08 The automatic tape reader can be stopped either permanently or temporarily. When the reader is stopped permanently it cannot be started again automatically but must be started manually. When temporarily stopped, the reader can be started again either automatically or manually.

**Permanent Stop**

4.09 Besides the stop contact wires mentioned in 4.07, the following are normally closed contacts wired in series with the relay in the power pack:

- (a) Tape-out contact wires
- (b) Tape reader OFF function box contact
- (c) WRU function box contact

When one of these contacts is momentarily opened, the relay is de-energized, opening two relay contacts. One of these relay contacts

opens the reader trip magnet circuit. The trip magnet de-energizes causing the reader to stop permanently.

**Temporary Stop**

**4.10** The following normally closed contact wires are wired in series with the reader trip magnet:

- (a) Form-out function box contact
- (b) Tight-tape contact wires

When one of these contacts is opened the trip magnet is de-energized stopping the tape reader temporarily.

**D. FREE Position (Figure 20)**

**4.11** When the control lever is placed in the FREE position the start and stop contacts are open. The tape reader will not respond to a remote reader start signal.



33 TAPE READER

LUBRICATION

CONTENTS	PAGE
1. GENERAL . . . . .	1
2. BASIC UNIT . . . . .	2
Armature shaft . . . . .	4
Clutch trip area . . . . .	6
Control mechanism . . . . .	5
Distributor clutch trip magnet . . . . .	7
Feed pawl mechanism . . . . .	5
Feed wheel . . . . .	4
Reader feed magnet contact . . . . .	7
Reader trip lever . . . . .	8
Tape lid mechanism . . . . .	6
Tape reader . . . . .	2
Tape reader mechanism . . . . .	3
Tight tape mechanism . . . . .	4

to make sure no areas have been missed. Thereafter, lubricate the tape reader at regular intervals as indicated below:

<u>Operating Speed</u> (Words per Minute)	<u>Lubrication</u> <u>Interval</u>
100	500 hours* or 6 months**

\*Station Set operating hours.  
\*\*Whichever comes first.

1.05 The textual instructions that accompany the line drawings consist of abbreviated directions, specific lubrication points, and parts affected. The meanings of the abbreviated directions (symbols) are given below:

<u>Symbol</u>	<u>Meaning</u>
D	Keep dry --- no lubricant permitted.
G	Apply thin coat of KS7471 grease.
L	Apply thin coat of Lubriplate 105 (2 oz tube TP108805).
O	Oil (KS7470 oil).

1.06 References to left, right, front, or rear, etc, consider the tape reader to be viewed from a position where the feed wheel faces up and the lid latch is to the viewer's right. Orientation references in the clutch trip area consider the armature extension to be facing up with the contact bracket pry points located to the viewer's right.

**CAUTION: DO NOT USE ALCOHOL, MINERAL SPIRITS, OR OTHER SOLVENTS TO CLEAN PLASTIC PARTS OR PARTS WITH PROTECTIVE, DECORATIVE FINISHES. NORMALLY, A SOFT, DRY CLOTH SHOULD BE USED TO REMOVE DUST, OIL, GREASE**

1. GENERAL

1.01 This section contains lubrication requirements for the tape reader. It is reissued to provide exclusive and updated 33 tape reader information. Since this is a general revision, marginal arrows used to indicate changes have been omitted.

1.02 The general lubrication areas are illustrated by photographs. The specific points to receive lubricant are indicated on line drawings with appropriate textual instructions. Line drawings and textual instructions follow each photograph and are keyed to the photograph by paragraph numbers.

1.03 Thoroughly lubricate the tape reader, but avoid over lubrication that might permit the lubricant to drip or be thrown onto adjacent parts. Saturate all felt washers.

1.04 Lubricate the tape reader before placing it into service or prior to storage. After a short period of service, relubricate it

SECTION 574-124-701TC

OR OTHERWISE CLEAN PARTS OR SUBASSEMBLIES. A SOFT CLOTH DAMPENED WITH SOAP OR MILD DETERGENT MAY BE USED. RINSE WITH A SOFT, DAMPCLOTH AND BUFF WITH A SOFT, DRY CLOTH.

- 1.07 Materials needed for lubrication are listed in Section 570-005-800TC.

- 1.08 For disassembly and reassembly information, refer to Section 574-124-702.

**CAUTION:** REMOVE ALL ELECTRICAL POWER FROM UNIT BEFORE LUBRICATING OR DISASSEMBLING COMPONENTS.

2. BASIC UNIT

2.01 Tape Reader

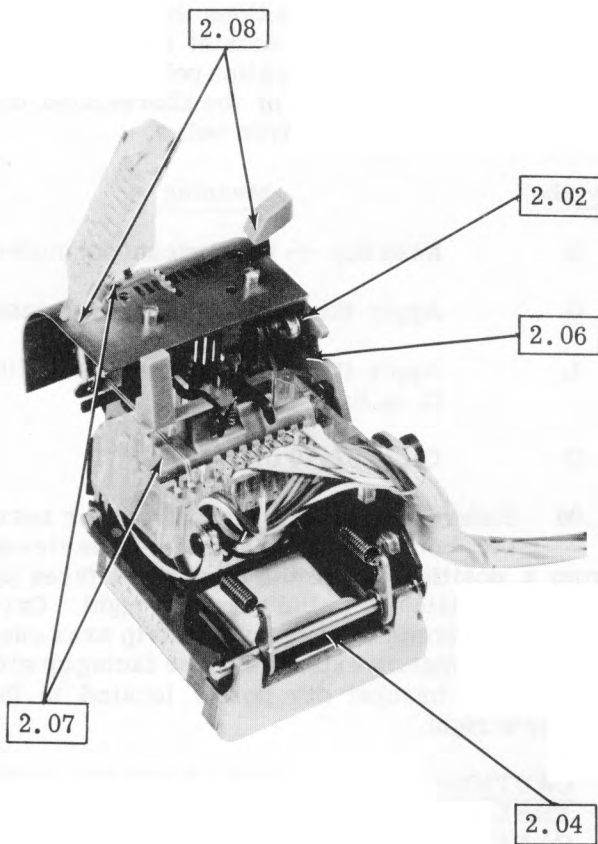

(Left Front View)

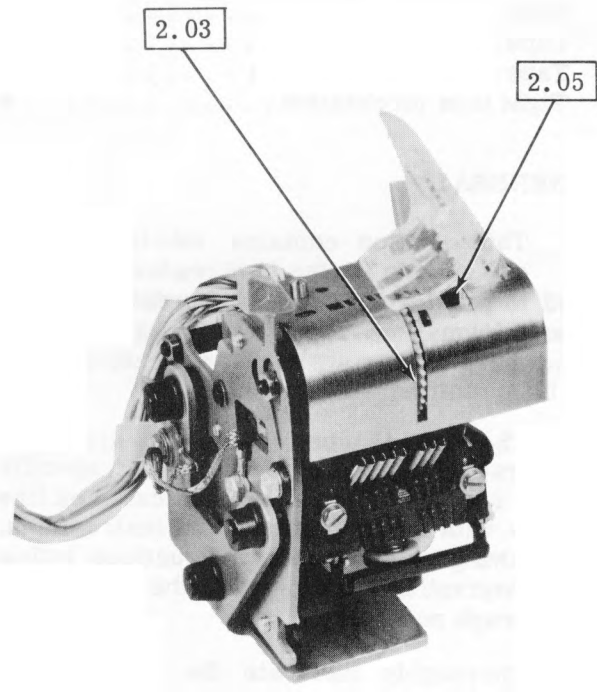

(Right Rear View)

2.02 Tape Reader Mechanism

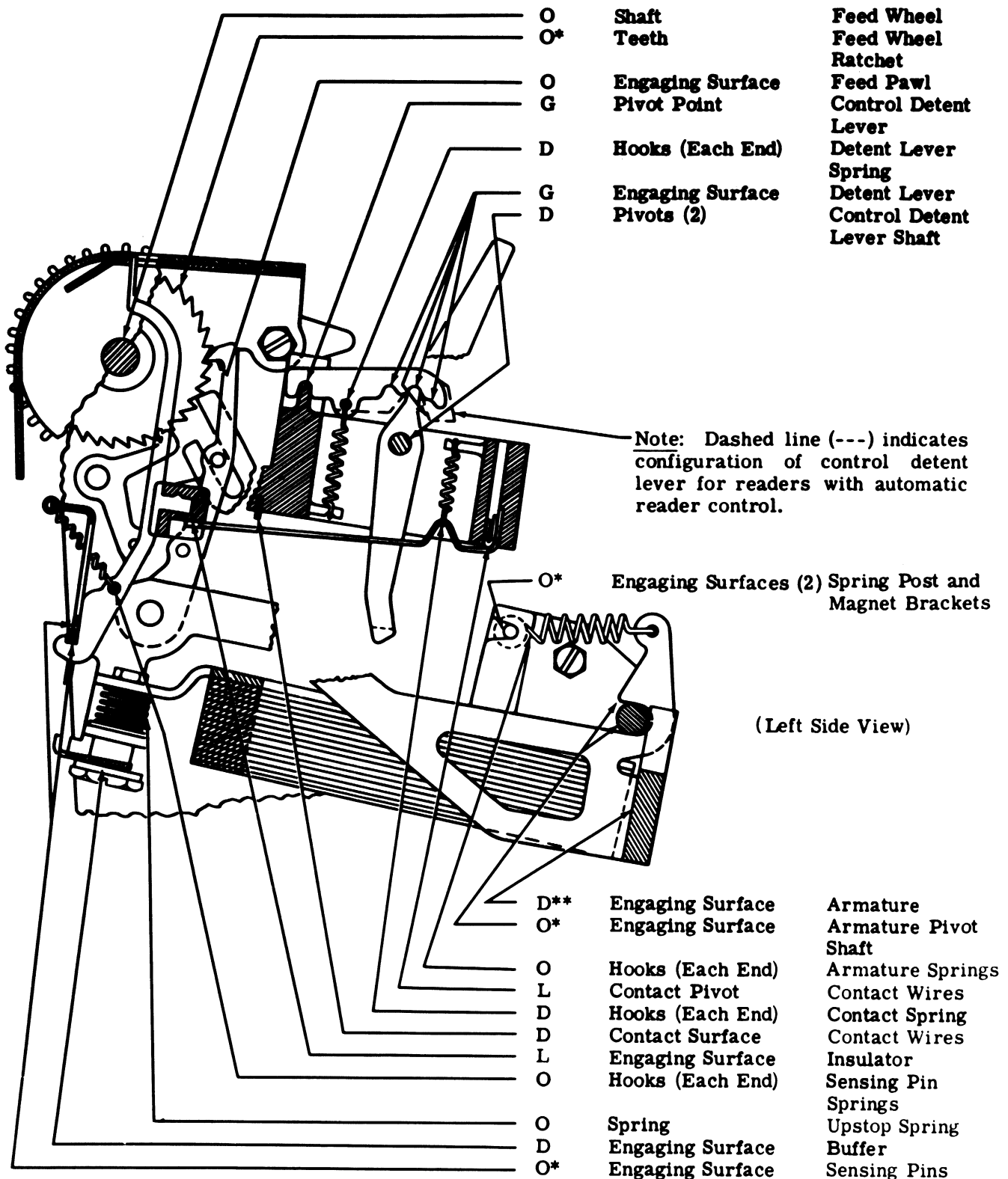

\*At 1500 hour lubrication intervals, apply with a coat of thoroughly mixed 50 percent KS7470 oil and 50 percent KS7471 grease.

\*\*Some oil leakage on this surface is permissible.



SECTION 574-124-701TC

2.03 Feed Wheel

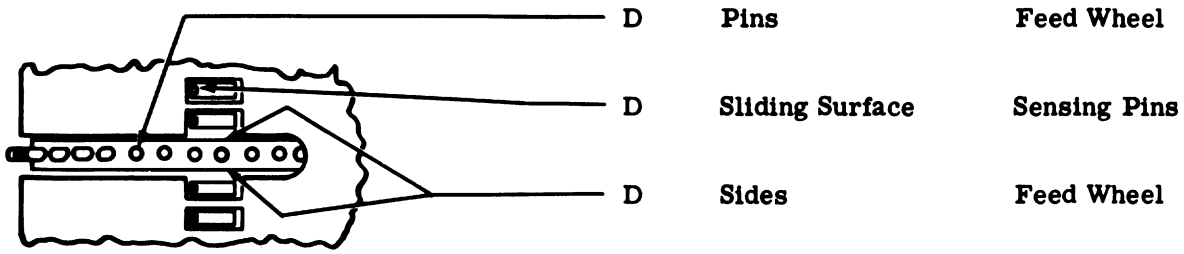

(Top View)

2.04 Armature Shaft

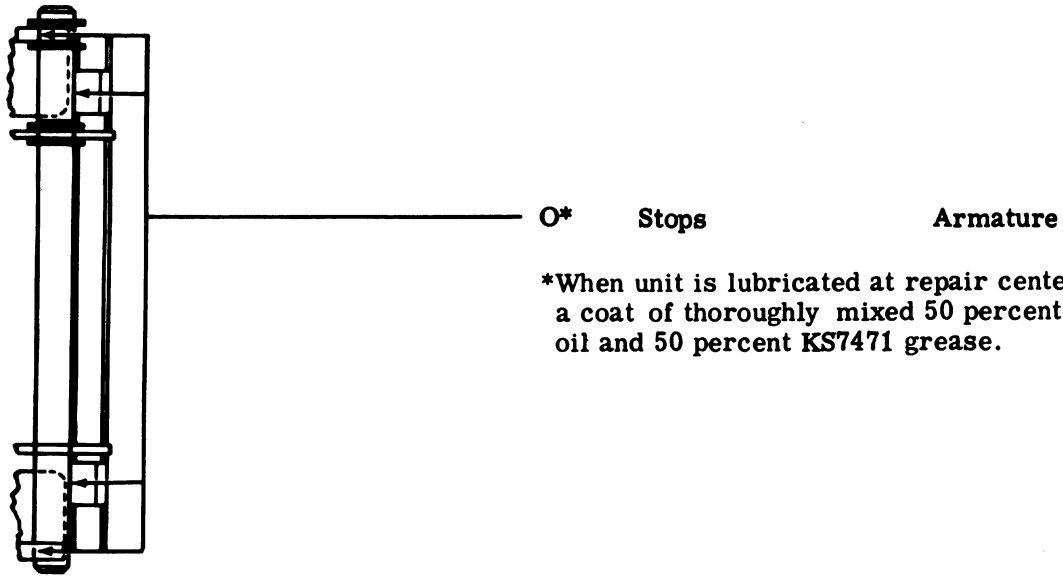

\*When unit is lubricated at repair center, apply a coat of thoroughly mixed 50 percent KS7470 oil and 50 percent KS7471 grease.

(Top View)

2.05 Tight Tape Mechanism

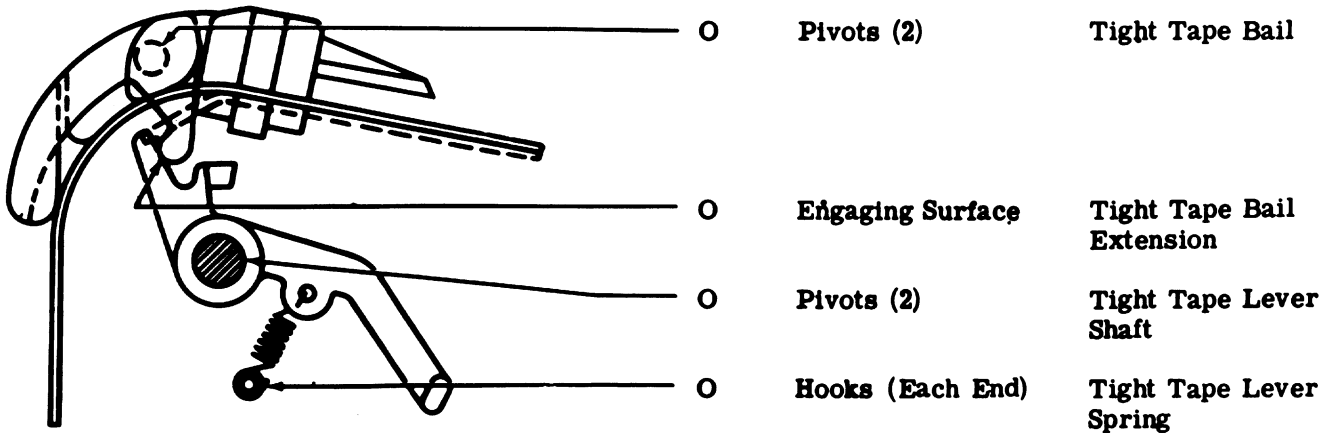

(Left Side View)

2.06 Feed Pawl Mechanism

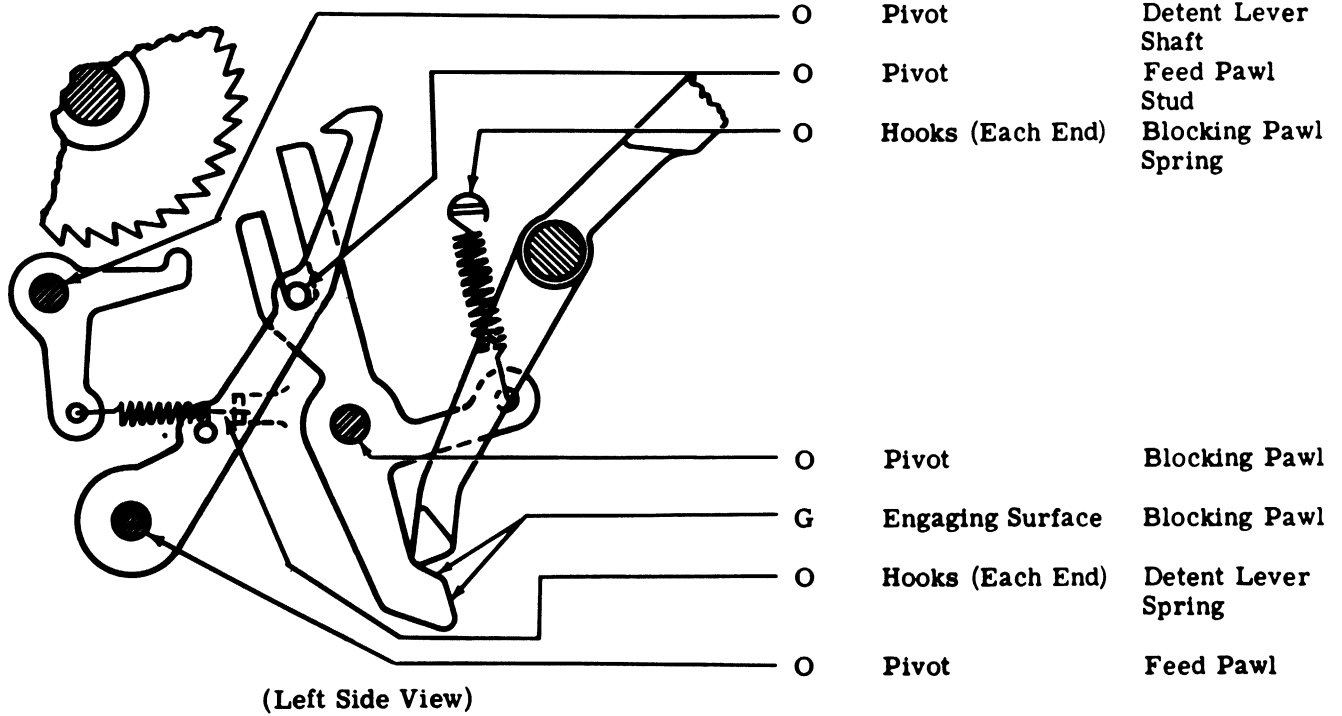

2.07 Control Mechanism

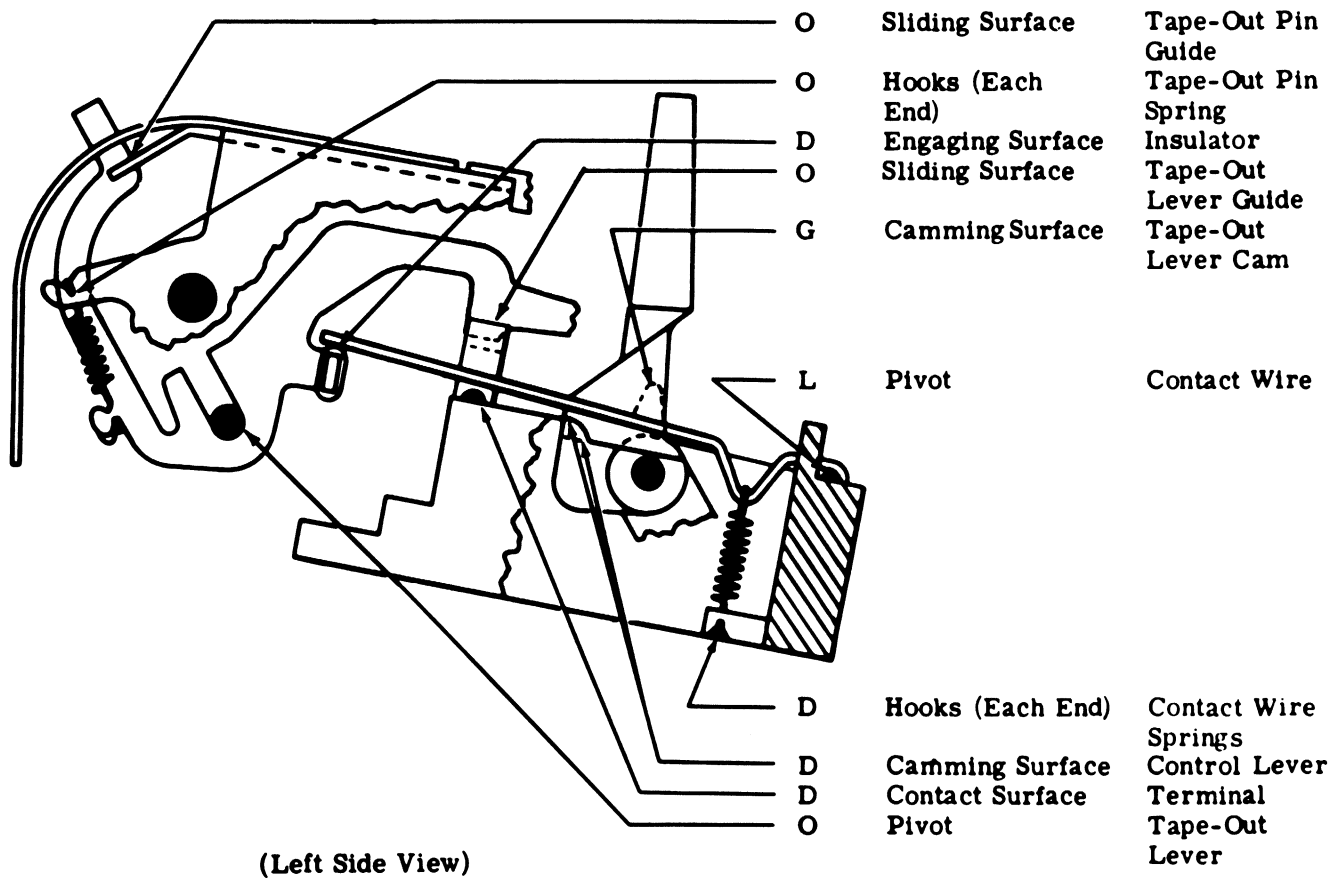

2.08 Tape Lid Mechanism

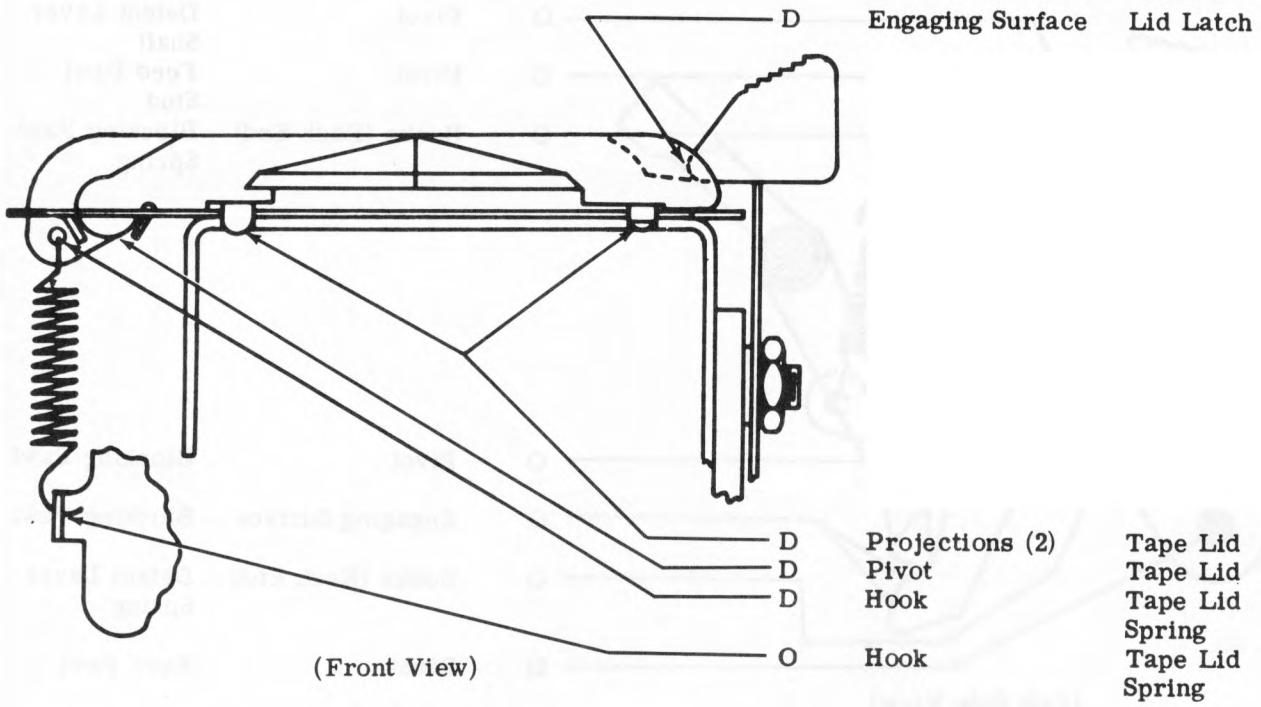

2.09 Clutch Trip Area

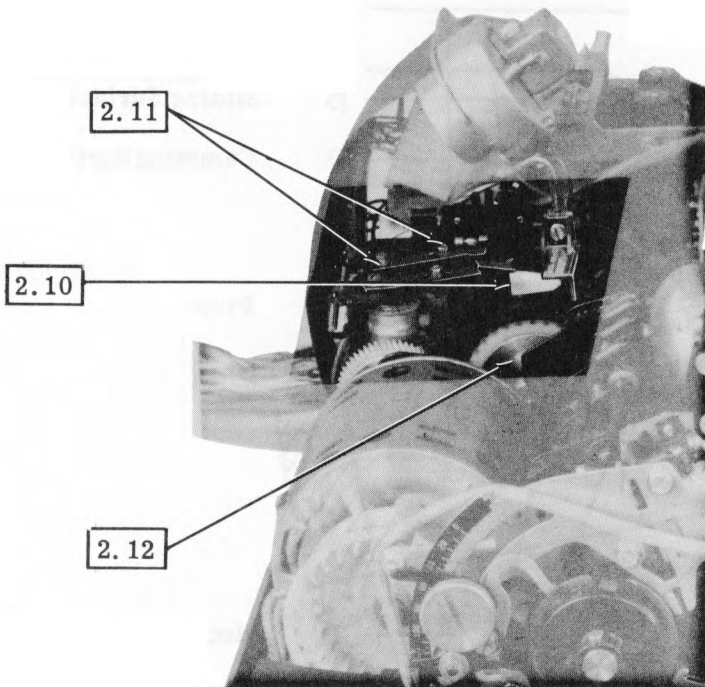

(Left Side View)

2.10 Reader Feed Magnet Contact

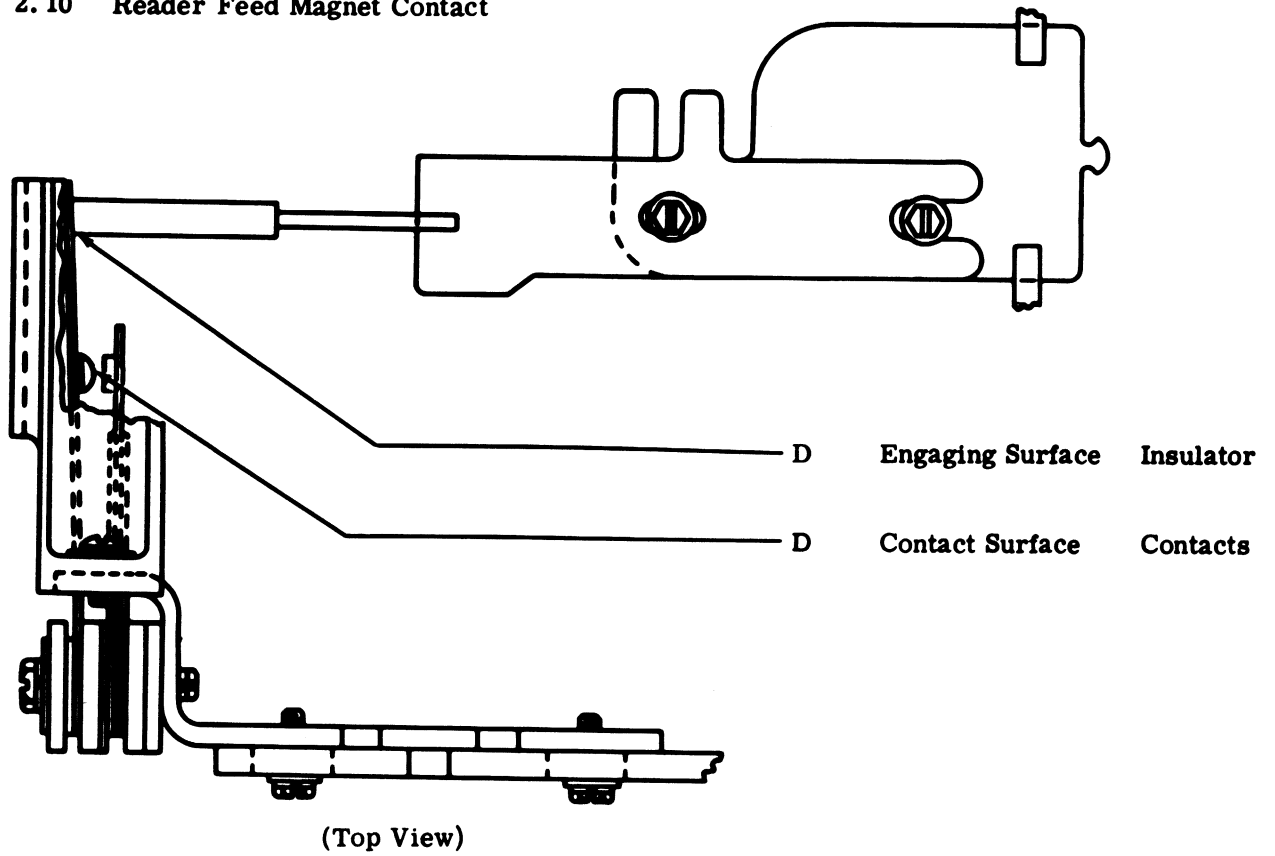

2.11 Distributor Clutch Trip Magnet

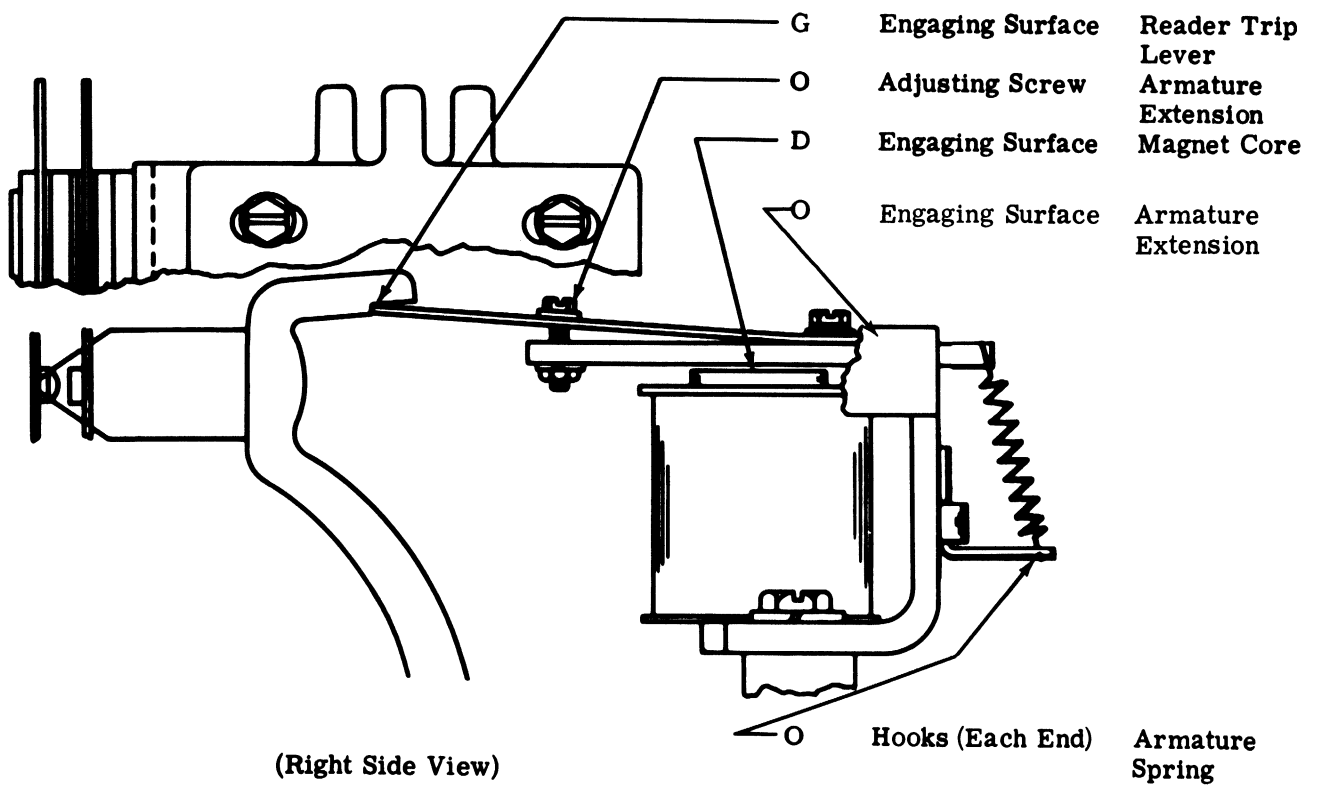

SECTION 574-124-701TC

2.12 Reader Trip Lever

(Remove answer-back drum.)

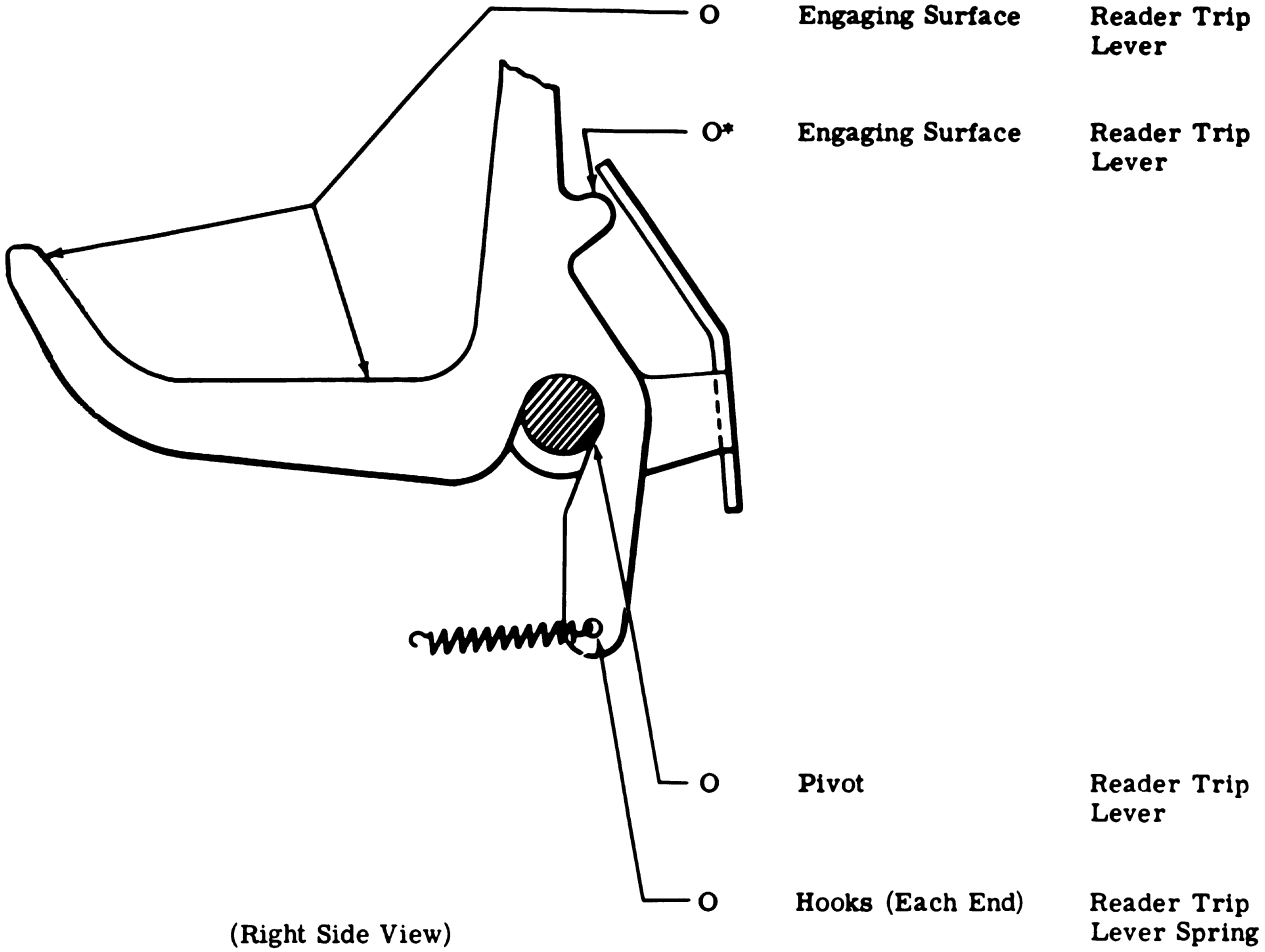

(Replace answer-back drum.)

\*At 1500 hour lubrication intervals, apply a coat of thoroughly mixed 50 percent KS7470 oil and 50 percent KS7471 grease.

### 33 TAPE READER

#### DISASSEMBLY AND REASSEMBLY

CONTENTS	PAGE
1. GENERAL . . . . .	1
2. DISASSEMBLY AND REASSEMBLY . .	1
SENSING PIN ASSEMBLY . . . . .	1
FEED MAGNET ASSEMBLY . . . . .	1
FEED WHEEL AND TOP PLATE ASSEMBLY . . . . .	2
TAPE READER FEED MAGNET CONTACT . . . . .	2
TAPE READER CLUTCH TRIP MAGNET ASSEMBLY . . . . .	3

#### 1. GENERAL

1.01 This section is reissued to incorporate recent engineering changes and to present disassembly and reassembly information exclusively for 33 tape readers. Since this is a general revision, marginal arrows, used to indicate changes, have been omitted.

1.02 References to left, right, front, rear, etc, consider the tape reader to be viewed from a position where the feed wheel faces up and the lid latch is to the viewer's right.

1.03 Disassembly, as outlined in this section, covers the procedure for removing the principle subassemblies which make up the unit. If further disassembly is required, refer to the appropriate illustrated parts section which shows detailed arrangements of parts. Where it will help in determining location, the numbers of the parts are given in the instructions.

1.04 All tools used to remove the various assemblies referred to in this section can be found in the standard tool section 570-005-800TC.

1.05 All damaged, worn, or distorted parts should be replaced if encountered in the disassembly and reassembly procedures.

#### 2. DISASSEMBLY AND REASSEMBLY

Note: For information concerning the proper procedure to remove the tape reader and associated cable assemblies from the set, refer to appropriate set disassembly and reassembly section.

#### SENSING PIN ASSEMBLY

2.01 To remove the sensing pin assembly (Figure 2), proceed as follows.

(a) Remove the two TP151152 mounting screws, TP110743 lockwashers, and TP104807 flat washers which mount the TP183035 sensing pin guide.

(b) Remove sensing pin assembly.

(c) To replace sensing pin assembly, reverse procedure used to remove it.

#### FEED MAGNET ASSEMBLY

2.02 To remove the feed magnet assembly (Figure 1), proceed as follows.

(a) Remove contact block assembly.

(b) Remove sensing pin assembly.

(c) Unhook the TP90517 detent lever spring from the TP183023 detent bracket.

(d) Unhook the TP114107 blocking pawl spring from the TP183020 blocking pawl bracket.

(e) Remove the TP151152 magnet bracket mounting screw, the TP110743 lockwasher, and the TP104807 washer. Then, remove the two TP181241 magnet bracket mounting screws.

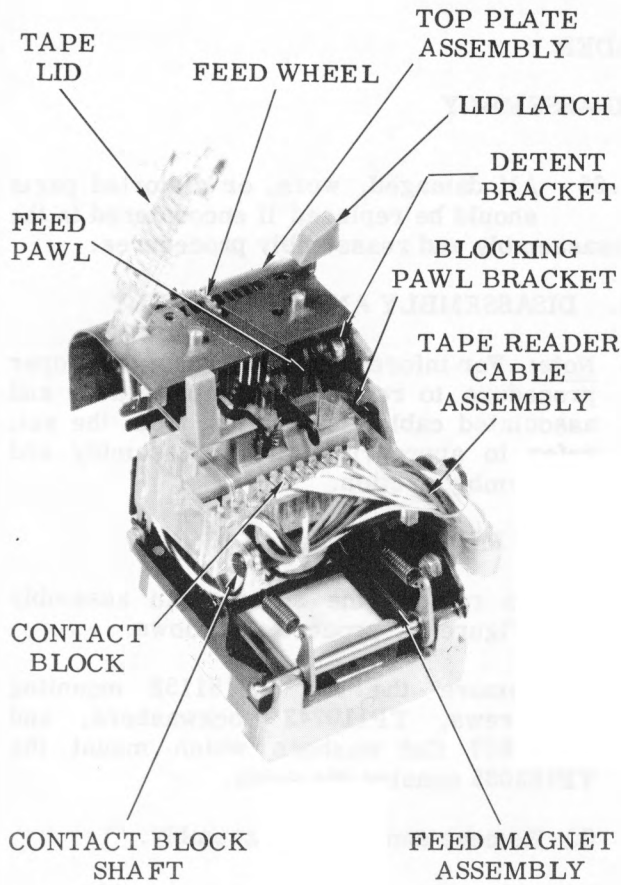

(Left Front View)

Figure 1 - Tape Reader (Without Cover)

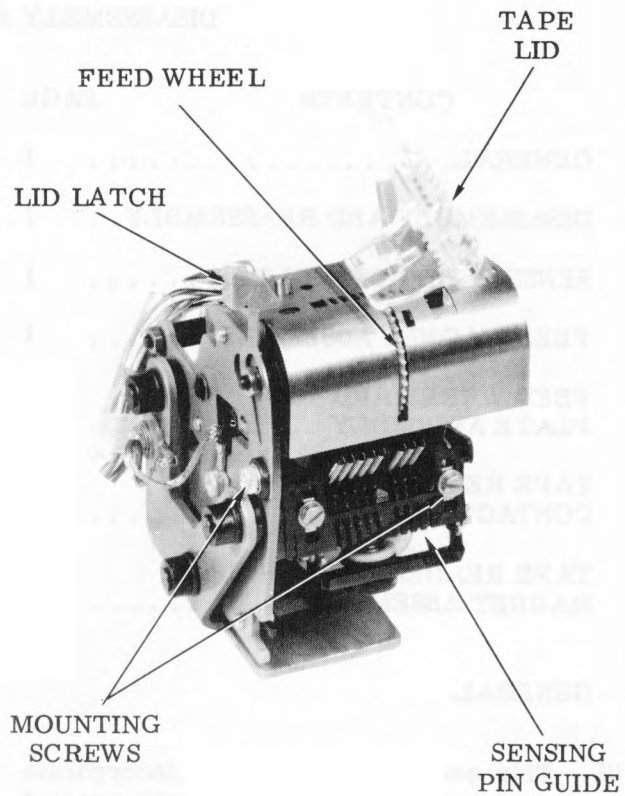

(Right Rear View)

Figure 2 - Tape Reader (Without Cover)

(f) Slide the TP183011 feed pawl stud out of engagement with the TP183016 blocking pawl.

(g) Remove feed magnet assembly.

(h) To replace feed magnet assembly, reverse procedure used to remove it.

**FEED WHEEL AND TOP PLATE ASSEMBLY**

2.03 To remove feed wheel and top plate assembly (Figure 1), proceed as follows.

(a) Remove contact block and cable assembly.

(b) Remove sensing pin assembly.

(c) Remove the TP182139 feed magnet assembly.

(d) Unlatch the TP183032 tape lid.

(e) Remove the TP181241 detent bracket mounting screw and TP3598 feed wheel shaft nut and TP124177 lockwasher.

(f) Remove feed wheel and top plate assembly.

(g) To replace feed wheel and top plate assembly, reverse procedure used to remove it.

**TAPE READER FEED MAGNET CONTACT**

2.04 To remove the tape reader feed magnet contact (Figure 3), proceed as follows.

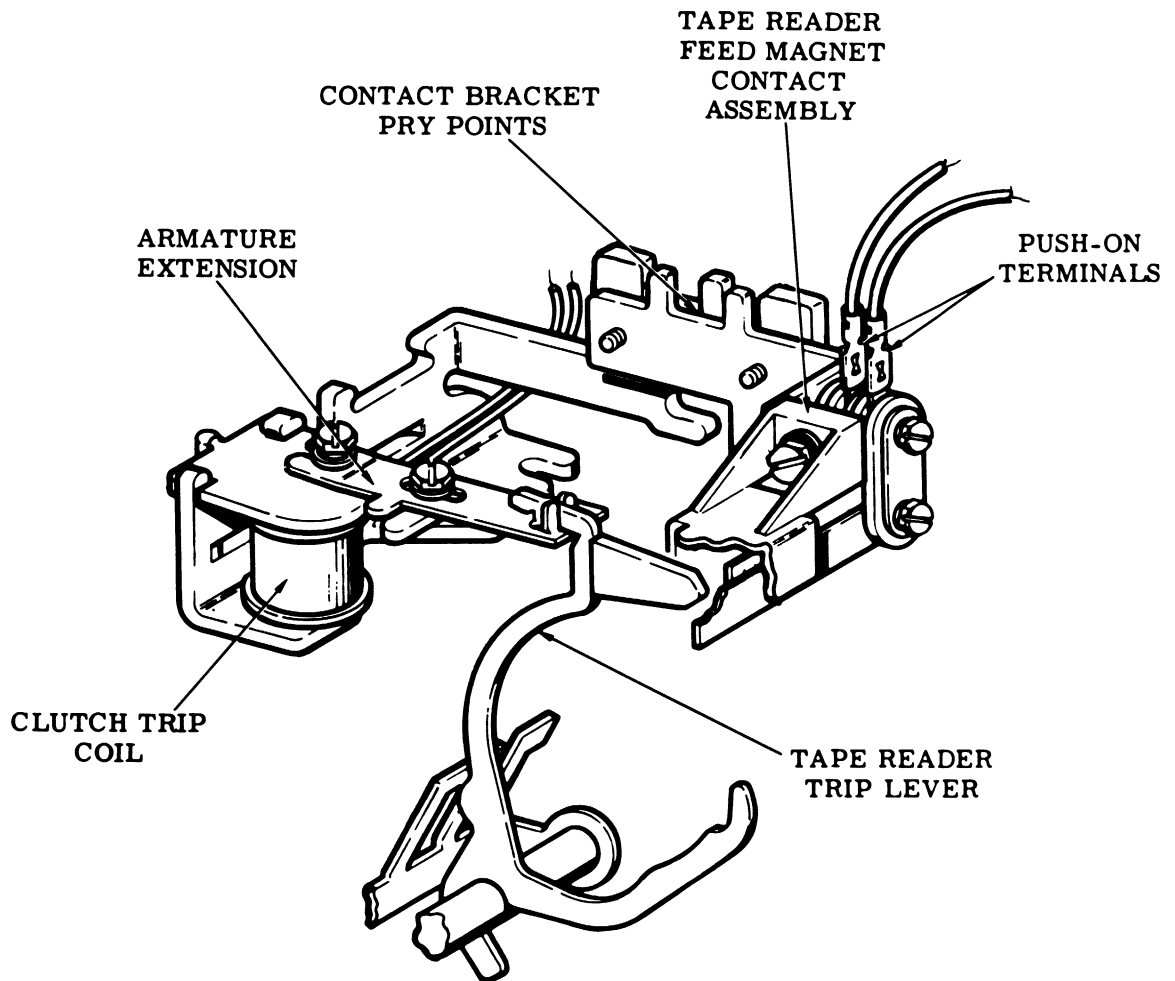

Figure 3 - Clutch Trip Magnet Assembly

- (a) Remove the two push-on TP182726 terminals of the tape reader cable.
- (b) Remove the two TP152893 tape reader feed magnet mounting screws, two TP104807 flat washers, and two TP110743 lockwashers.
- (c) Remove the tape reader feed magnet contact assembly.
- (d) To replace the tape reader feed magnet contact assembly, reverse procedure used to remove it.

#### TAPE READER CLUTCH TRIP MAGNET ASSEMBLY

- 2.05 To remove tape reader clutch trip magnet assembly (Figure 3), proceed as follows.

- (a) Remove the tape reader feed magnet contact assembly.
- (b) Remove plug no. 4 and, with extractor tool TP182697, remove terminals no. 11 and 12.
- (c) Loosen the two TP180989 distributor disc mounting screws and the TP180798 magnet bracket mounting screw.
- (d) Remove tape reader clutch trip magnet assembly.
- (e) To replace tape reader clutch trip magnet assembly, reverse procedure used to remove it.





**33 TAPE PUNCH**  
**GENERAL DESCRIPTION**  
**AND**  
**PRINCIPLES OF OPERATION**

CONTENTS	PAGE
1. GENERAL . . . . .	1
2. TECHNICAL DATA . . . . .	3
3. OUTLINE OF OPERATION . . . . .	3
4. DETAILED OPERATION . . . . .	4
DRIVE MECHANISM . . . . .	4
INTELLIGENCE TRANSFER MECHANISM . . . . .	4
TAPE FEED MECHANISM . . . . .	7
TAPE GUIDE MECHANISM . . . . .	7
PUNCH BLOCK MECHANISM . . . . .	7
BACKSPACE MECHANISM . . . . .	8
5. CONTROL FEATURES . . . . .	8
MANUAL CONTROL FEATURES . . . . .	9
AUTOMATIC CONTROL FEATURES . . . . .	9
VARIABLE FEATURES . . . . .	11

**1. GENERAL**

1.01 This section provides general description and principles of operation for the 33 tape punch (Figure 1). It is reissued to remove information covering the 32 tape punch, which now appears in Section 574-175-100TC, to incorporate engineering changes and to add information on the manual and automatic control features, and variable features. Since this is a general revision, marginal arrows normally used to in-

dicating changes have been omitted.

1.02 The 33 tape punch is an 8-level device which perforates paper tape according to a code. The tape punch does not receive pulses from a transmitting set directly but uses the coded arrangement of the typing unit codebars. The signaling code is described in the appropriate typing unit section.

1.03 References to left, right, front, or rear, etc consider the tape punch as viewed by the teletypewriter operator.

1.04 In the illustrations, fixed pivots are solid black and floating points, those mounted on parts that move, are cross-hatched.

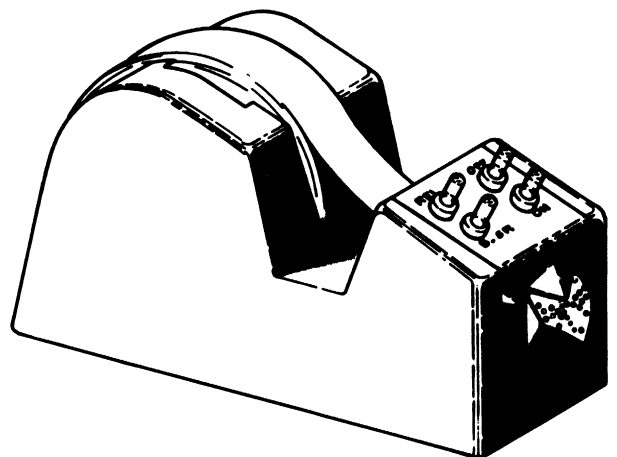

Figure 1 - 33 Tape Punch

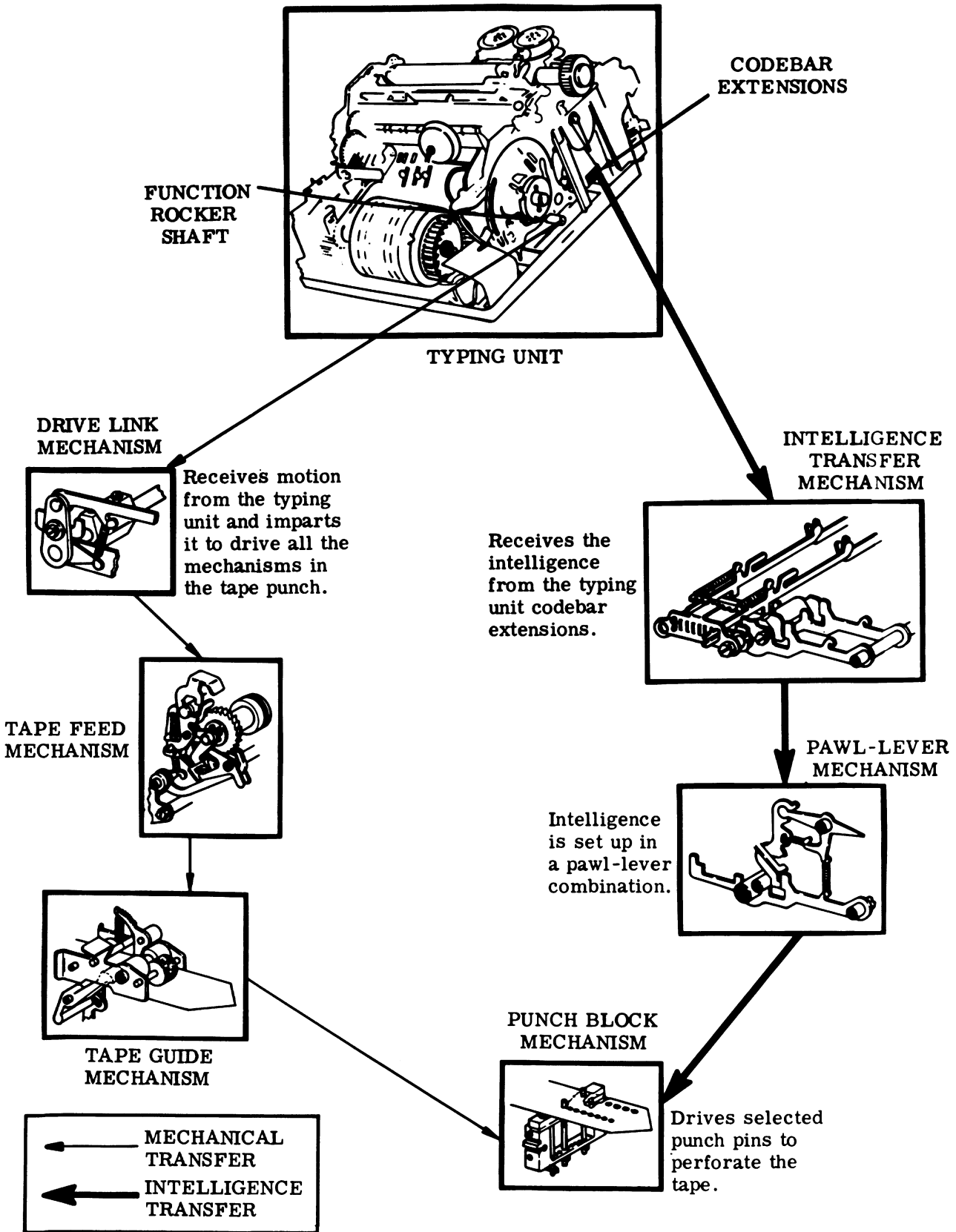

Figure 2 - Functional Diagram of the Tape Punch and Major Mechanisms

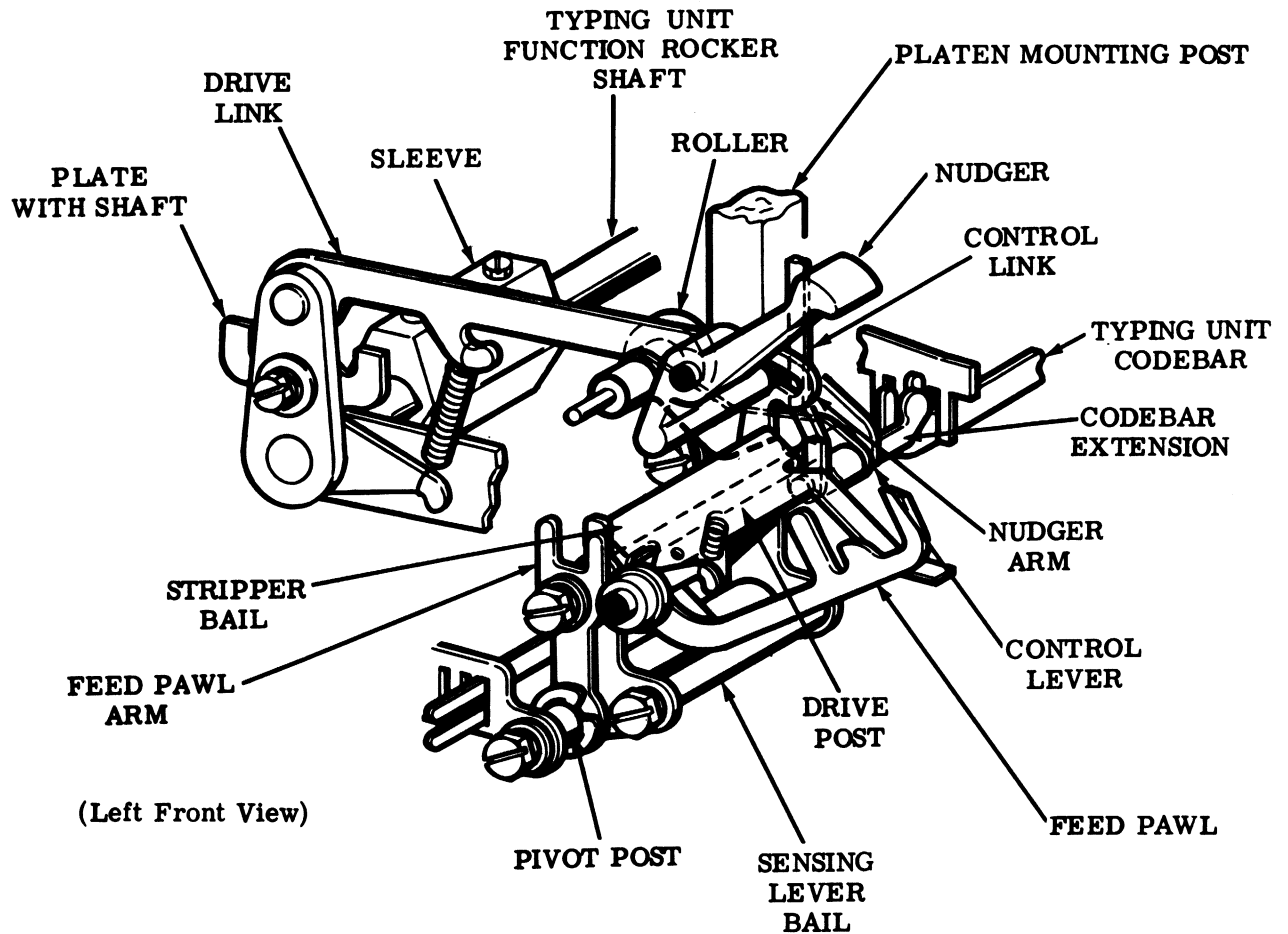

Figure 3 - Drive Link Mechanism and Drive Mechanism

**2. TECHNICAL DATA**

**2.01 Dimensions and Weight**

Width . . . . .	4 inches
Height . . . . .	6 inches
Depth . . . . .	6 inches
Weight . . . . .	21 ounces

**2.02 Tape Specifications**

Level . . . . .	.8 level
Width . . . . .	1 inch
Code combination per inch . . . . .	.10
Feed hole diameter . . . . .	0.046 inch

**2.03 Chad Box**

Width . . . . .	2 inches
Length . . . . .	6.5 inches
Height . . . . .	7.5 inches

2.04 The 33 tape punch is capable of operating at 60, 66, 75, or 100 words per minute.

**3. OUTLINE OF OPERATION**

3.01 The tape punch receives its drive motion and intelligence from the typing unit (Figure 2).

3.02 The drive motion originates in the typing unit function mechanism. A cam on the function clutch imparts motion to the function rocker shaft. The motion of the function rocker shaft is then transferred to the tape punch by means of drive linkages.

3.03 The tape punch receives its intelligence from the typing unit codebars. Pulses received by the selector mechanism are converted into a mechanical arrangement of the

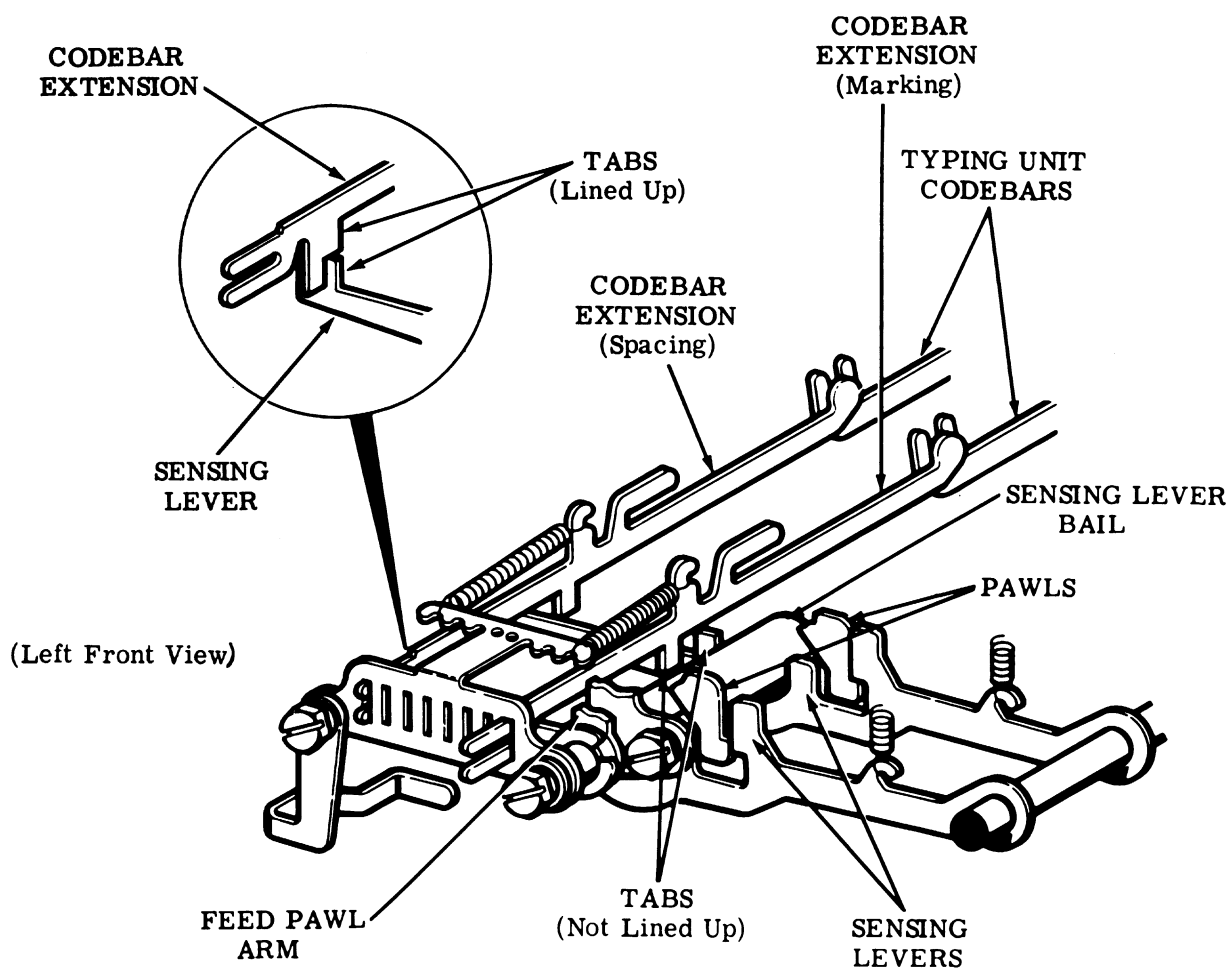

Figure 4 - Intelligence Transfer Mechanism

codebars. Codebar extensions, attached to the codebars, present this arrangement to mechanisms in the tape punch which, in turn, translate it into perforations in the tape. Briefly, the drive mechanism imparts the motion received from the rocker shaft to advance, guide, punch, and backspace the tape. The intelligence transfer mechanism duplicates the code arrangement of the typing unit codebars by setting up punch pins which rise to perforate the tape (Figure 2).

#### 4. DETAILED OPERATION

##### DRIVE MECHANISM

4.01 The rocking motion of the function rocker shaft is imparted to the tape punch by means of a sleeve which connects to a plate with shaft (Figure 3). A drive link, attached to the plate with shaft, connects to a drive post which

simultaneously drives the nudger, feed pawl, and stripper bail, and supplies the downward force to pull the selected pawls by means of the sensing lever bail.

##### INTELLIGENCE TRANSFER MECHANISM

4.02 There is a codebar extension (Figure 4) for each typing unit codebar. Motion is imparted to the codebar extensions by the codebars through the typing unit reset bail. A plate mounted to the tape punch casting guides the codebar extensions.

4.03 The typing unit selector blocking levers control the mark or space position of the codebars which, in turn, transfer this position to the codebar extensions. A blocked codebar represents a space; an unblocked codebar represents a mark.

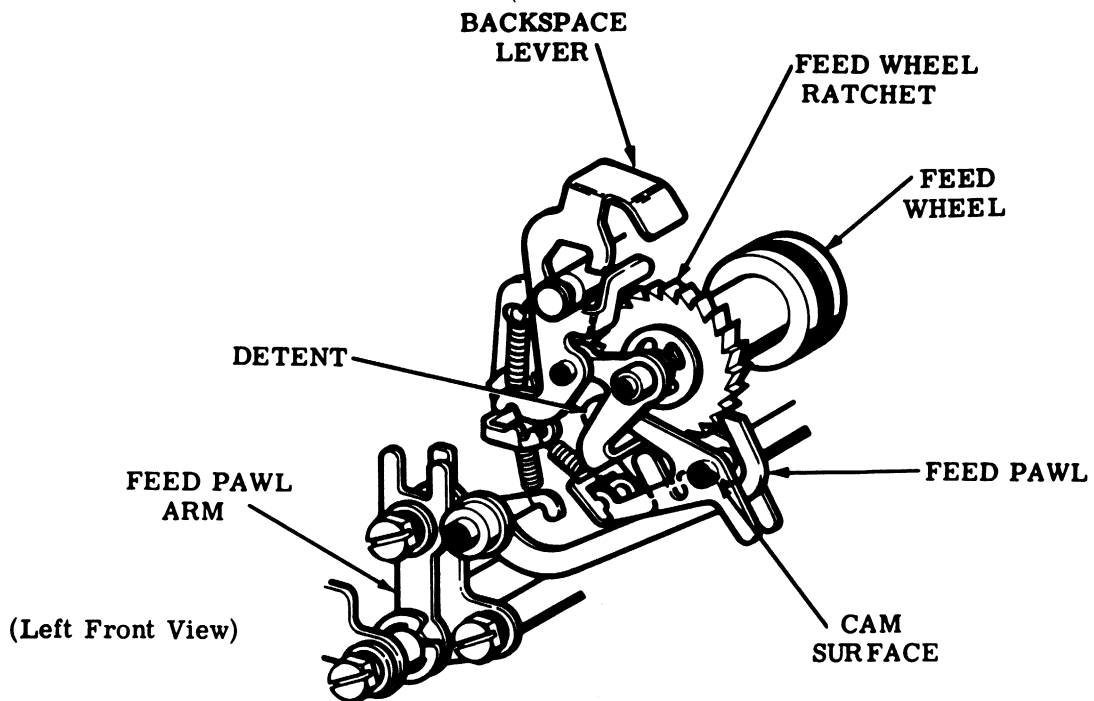

Figure 5 - Feed Wheel Mechanism (Tape Feed Mechanism)

4.04 Each codebar extension has a tab on its underside which lines up with its respective sensing lever, pawl, lever, and punch-pin combination.

4.05 During the drive mechanism's counterclockwise travel, the sensing levers, under spring tension, move up and sense the codebar extensions. Each sensing lever, except the feed lever, has a tab on its top side which lines up with its respective codebar extension.

4.06 When a codebar extension is spacing, the tab, located on its underside, lines up with the tab on the sensing lever. The tabs engage each other, and the sensing lever is blocked from pivoting to its most counterclockwise position.

4.07 When a codebar extension is marking, its tab is not in line with the sensing lever tab. As a result the sensing lever pivots to its most clockwise position.

4.08 The feed sensing lever always travels to its most clockwise position, since it has no tabs. This motion is presented to the pawl, lever, and feed-punch pin combination through a latching surface on the pawl.

4.09 When the tape punch is off, each pawl is in its highest vertical position, each lever in its most clockwise position, and each code-punch pin in its most downward position — below the surface of the tape.

4.10 When a sensing lever is in the spacing position, its latching surface is prevented from engaging with its associated pawl latching surface. As a result the pawl is not selected.

4.11 When a sensing lever is in the marking position, its latching surface engages the latching surface on its associated pawl. When the two latching surfaces engage, the pawl is in the selected position.

4.12 As the drive mechanism (Figure 3) rotates clockwise, the feed pawl slides along the inclined surface of the adjacent ratchet tooth, drops behind it, and is cammed away from the feed wheel ratchet. Occurring simultaneously, the sensing levers in the marking position rotate counterclockwise and transfer their motion to the selected pawl, lever, and code-punch pin combination. At the same time, the drive mechanism transfers its motion to the sensing levers which are spacing. Since the pawl, lever, and code-punch pin combinations

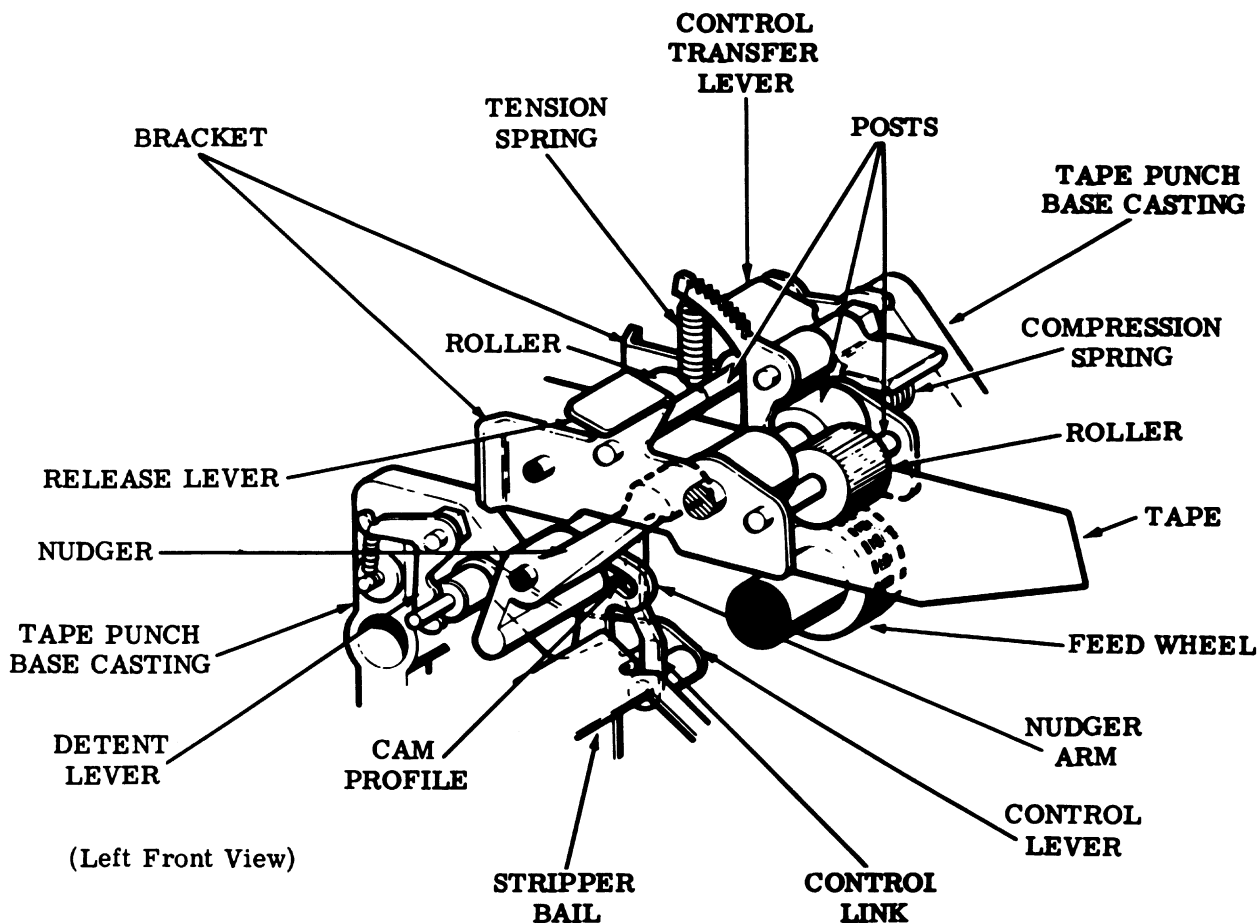

Figure 6 - Tape Guide Assembly (Tape Feed Mechanism)

are in the nonselected position, no motion is transferred to them. This results in no perforation of the tape, since the code-punch pins remain in their most downward position below the tape's surface. As the drive mechanism continues and reaches its most clockwise position, the code-punch pin of a selected pawl, lever, and code-punch pin combination travels upwards, perforates a hole in the tape, and continues to its most vertical position. The feed hole is always perforated in the tape since its pawl and lever are always selected.

4.13 Just prior to the end of the drive mechanism's most clockwise travel, the stripper bail, through its bias spring, engages a latching surface located under the spring hook(s) of the selected pawl(s). As the drive mechanism rotates counterclockwise to its stop position, the stripper bail strips the selected pawls from their sensing levers. The selected pawl, lever, and code-punch pin combinations

return to their stop positions through their bias springs and the retractor mechanism. The lever bail of the drive mechanism also acts as a part of the retractor mechanism. As the stripper bail strips the pawls, a cam surface on the pawl, which acts as the other member of the retractor mechanism, engages the sensing lever bail post and cams the pawl upwards to the stop position. During this portion of the drive mechanism's travel, the codebar extensions are reset by the codebar reset bail.

4.14 During the drive mechanism's clockwise motion, the nudger (Figure 3) performs its function. Motion is transferred from a cam profile, located on the nudger arm, through a post molded as an integral part of the nudger. The nudger rotates counterclockwise, engages, and nudges the tape gently when the selected code-punch pins are engaged with the tape. This enables the tape to be advanced a small amount without affecting tape feed spacing, since only

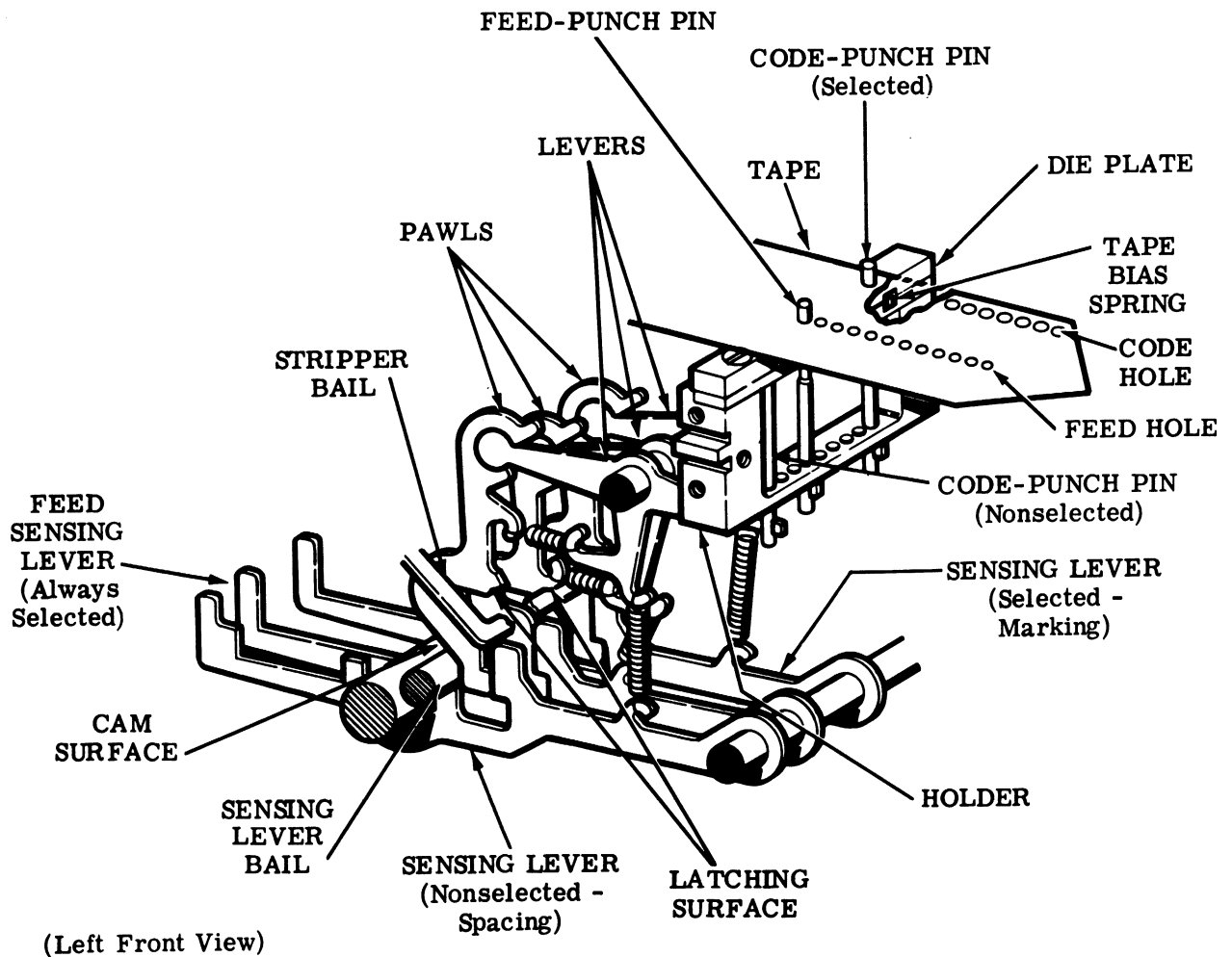

Figure 7 - Tape Punch Mechanism

the weight of the paper between the tape roll is reflected to the feed wheel when the tape is being advanced.

#### TAPE FEED MECHANISM

4.15 As the stripper bail moves to the rear, the feed pawl engages a tooth on the feed wheel ratchet (Figure 5). When the stripper bail completes its travel to the rear, the feed wheel ratchet has indexed one full tooth and the tape is advanced 0.100 inch by the feed wheel.

#### TAPE GUIDE MECHANISM

4.16 The tape guide mechanism (Figure 6), consists of a bracket, two rollers, three posts, a sleeve, and a compression spring held together by retainers. A tension spring biases the tape guide mechanism in a clockwise direction. The knurled roller settles against the

knurled feed wheel with a predetermined force. It is the combination of force and the knurled wheels that provides adequate tape spacing. The tape guide assembly is shaped in the form of a funnel to provide easy tape threading. A push-button (Figure 8), located in the cover lid, when manually pushed down against a tab located on the REL. bracket, disengages the tape guide assembly from the feed wheel, thereby providing easy tape removal from the tape punch.

#### PUNCH BLOCK MECHANISM

4.17 The punch block mechanism consists of code-punch pins, a feed-punch pin, holder, die plate, and a tape bias spring (Figure 7). The code-punch pin and feed-punch pin are oriented to the die plate through slots which engage levers for their respective code level. The tape bias spring always biases the tape against one edge of the holder. This results in



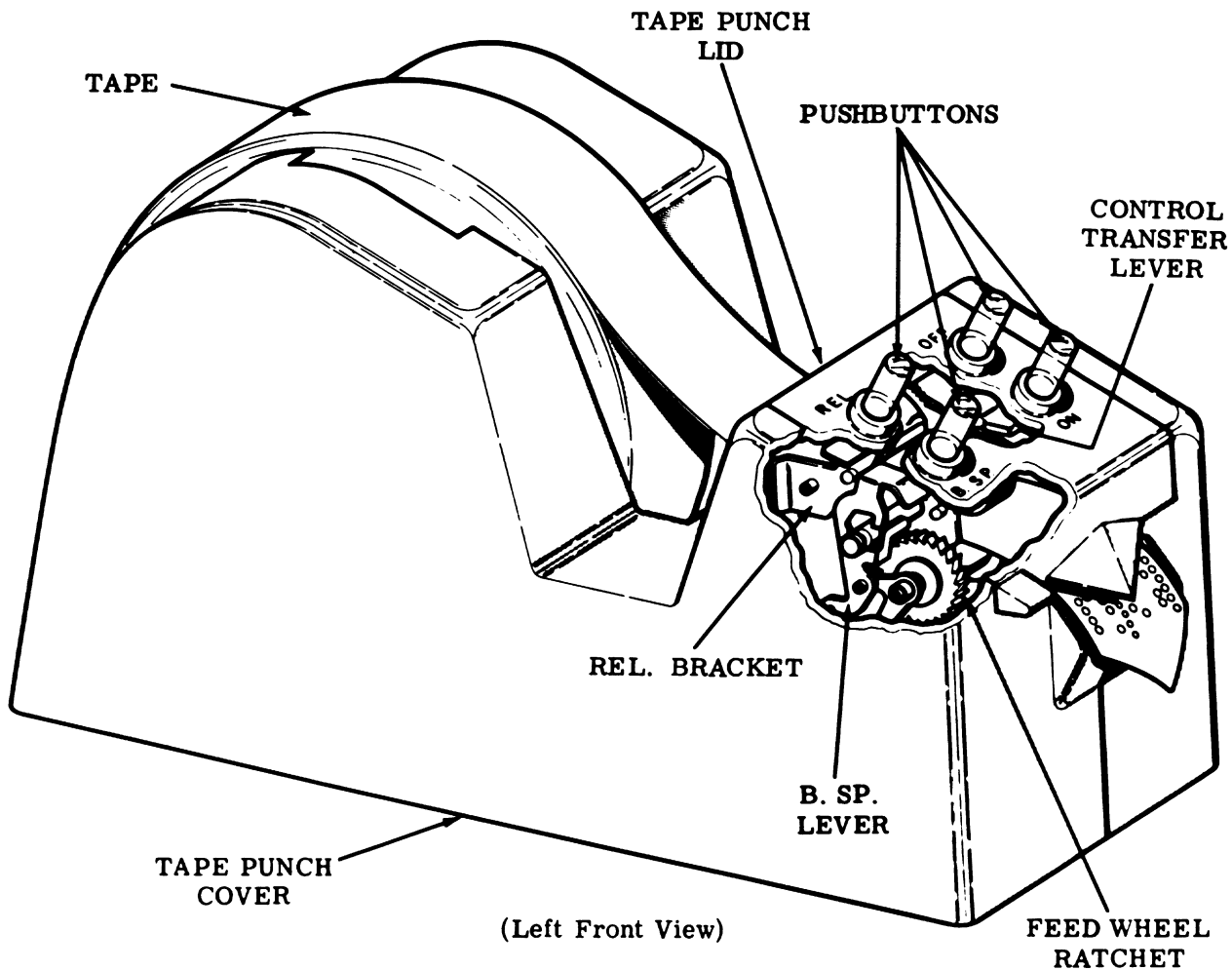

Figure 8 - Control Mechanism

the code hole and feed hole relation to the tape edge to be held constant.

**BACKSPACE MECHANISM**

4.18 The backspace lever (Figure 5), when depressed manually to its most downward position, backspaces the feed wheel ratchet one tooth space. This results in the tape being backspaced one full character. The backspace lever, through another lever, cams out the feed pawl during the backspace operation. This is a safety feature to prevent a jam if the operator accidentally operates the backspace mechanism while the tape punch is running.

**5. CONTROL FEATURES**

5.01 The control features on the tape punch are of two types:

- (a) Manual control features found on both the manual and the automatic punch.
- (b) Automatic control features found on the automatic punch only.

5.02 The difference between these control features is the way in which the punch can be turned ON or OFF. A punch with manual control features can only be turned ON or OFF

manually; a punch with automatic control features can be turned ON or OFF both manually and automatically.

<b>Manual Control Features</b> Manual and Automatic Punch	
ON OFF B. SP. (Backspace) REL. (Release)	
<b>Automatic Control Features</b> Automatic Punch Only	
Manual ON Manual OFF Automatic ON Automatic OFF	Manual B. SP. (Backspace) Manual REL. (Release)
<b>Variable Features</b>	
TAPE PUNCH INTERLOCK ON-LOCK UNLOCK CODE OPTION VISUAL ON-OFF NONCONTENTION E. O. T. (End of Transmission) SENSE SUPPRESSION	

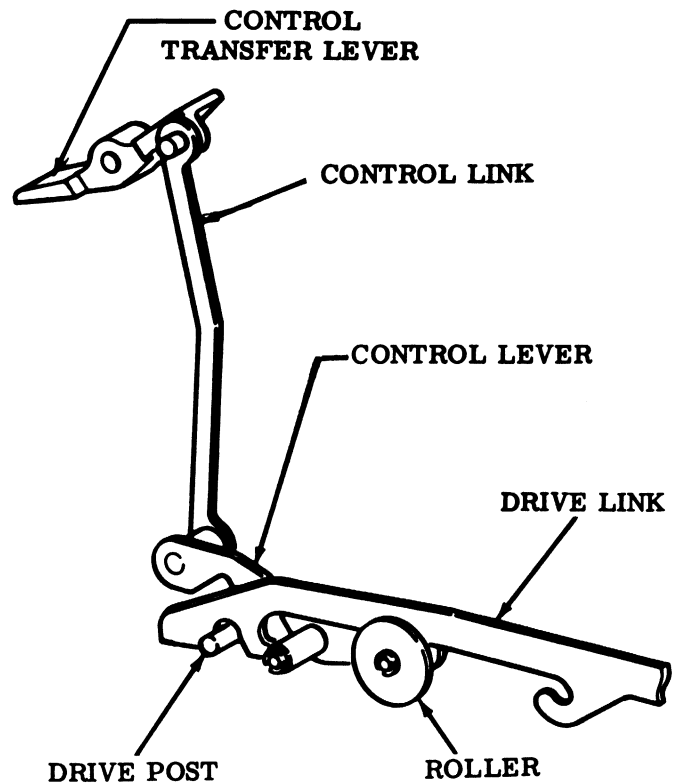

Figure 9 - Manual ON and OFF Mechanism

**MANUAL CONTROL FEATURES**

5.03 Tape Punch ON (Figure 9) - When the ON pushbutton on the cover is depressed, the control transfer lever operates a control link which, in turn, rotates the control lever. The control lever has a roller on one end and a detent on the other. The detent engages a drive post while the roller guides the drive link. When the control lever is rotated in the ON mode, the detent disengages from the drive post while the roller pivots downward. The drive link, under spring tension, is pulled downward to engage the drive post.

5.04 Tape Punch OFF (Figure 9) - When the OFF pushbutton on the cover is depressed, the process described in 5.03 is reversed. The control transfer lever operates the control link and then the control lever is operated. The detent on the control lever travels downward to engage the drive post while the roller pivots upward, disengaging the drive link from the drive post.

5.05 Backspace - When the B. SP. pushbutton on the cover is depressed, the backspace mechanism, described in 4.18, is operated. The backspace lever, when depressed, moves down to engage a tooth on the back side of the feed wheel ratchet (Figure 10). Simultaneously, a lever pivots the feed pawl away from the feed wheel ratchet which then turns counterclockwise, backspacing one tooth. The feed wheel is mounted on the same shaft as the ratchet. When the ratchet backspaces, the feed wheel also backspaces.

5.06 Release - When the REL. pushbutton on the cover is depressed, the entire backspace mechanism (Figure 6) pivots counterclockwise raising the roller away from the feed wheel. The tape can thus be pulled out freely.

**AUTOMATIC CONTROL FEATURES**

5.07 Manual ON (Figure 11) - Depressing the ON pushbutton on the cover lid causes a lever, link, the lever assembly, and the link with stud to pivot. In its pivoting motion, the stud causes the latch bail to pivot counterclockwise disengaging the ON-OFF bail lever, allowing it to move towards the rear. In this rearward

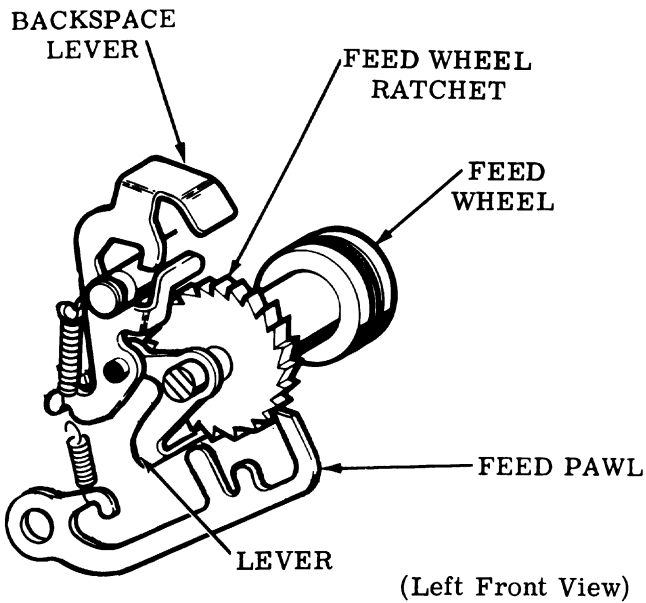

Figure 10 - Feed Wheel Mechanism (Tape Feed Mechanism)

travel the stud, which in the OFF condition holds the feed pawl down away from the feed wheel ratchet, also moves towards the rear allowing the feed pawl to reach up and engage a tooth on the feed wheel ratchet.

5.08 Manual OFF (Figure 11) - When the OFF pushbutton is depressed, its lever is pivoted away from the engaging surface of the ON lever allowing the spring-biased levers to return to their OFF position. The latch bail pivots upward to engage the ON-OFF bail lever and the stud moves the feed pawl downward away from the feed wheel ratchet teeth.

5.09 Manual Backspace - Same as the manual punch backspace operation described in 5.05.

5.10 Manual Release - Same as the manual punch release operation described in 5.06.

5.11 Automatic On (Figure 12) - For turning the tape punch ON automatically the same mechanism that turns it ON manually is used. When the "R" and "Control" keytops on the keyboard are depressed, a code combination is set up in the typing unit codebars and codebar extensions. The A-8 sensing lever senses the codebar extensions and travels upward, positioning a pawl

and lever. In its pivoting motion the lever engages an extension of the lever assembly causing it to pivot as described in 5.07. The pivoting action of the lever assembly causes the link with stud to pivot. Subsequently, the latch bail moves downward disengaging the ON-OFF bail whose stud moves away from the feed pawl. The feed pawl then reaches up to engage a tooth on the feed wheel ratchet.

5.12 Automatic OFF (Figure 13) - When the "T" and the "Control" keytops are depressed on the keyboard, the tape punch OFF

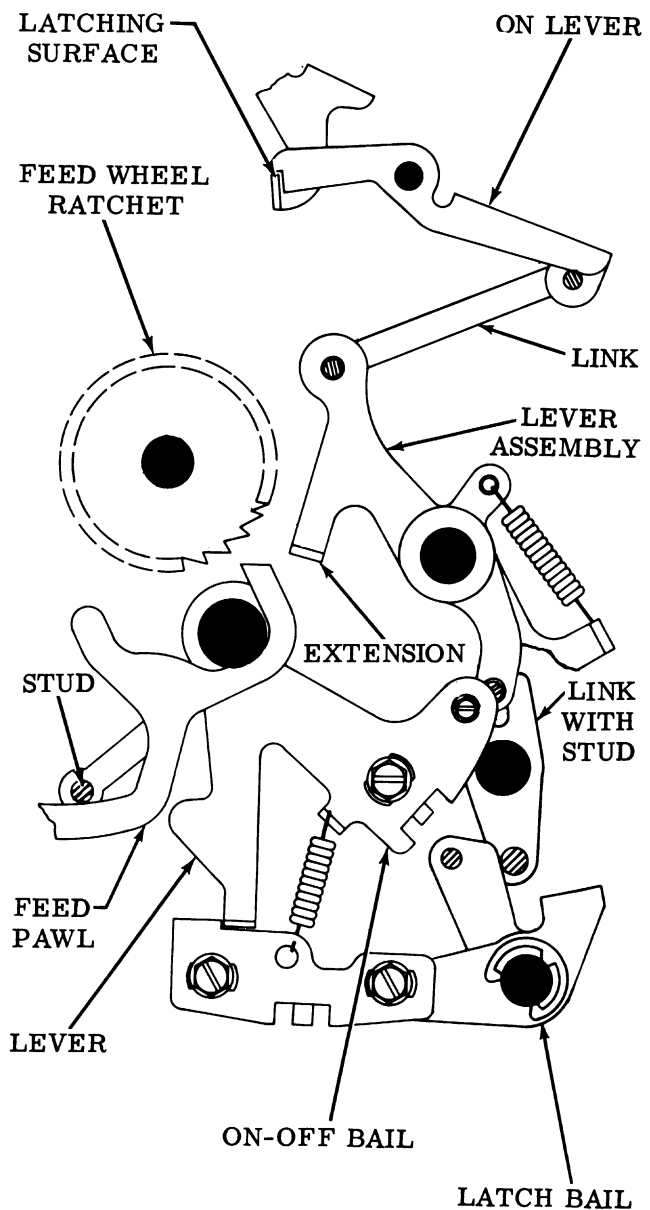

(Left Side View)

Figure 11 - Automatic ON and OFF Mechanism

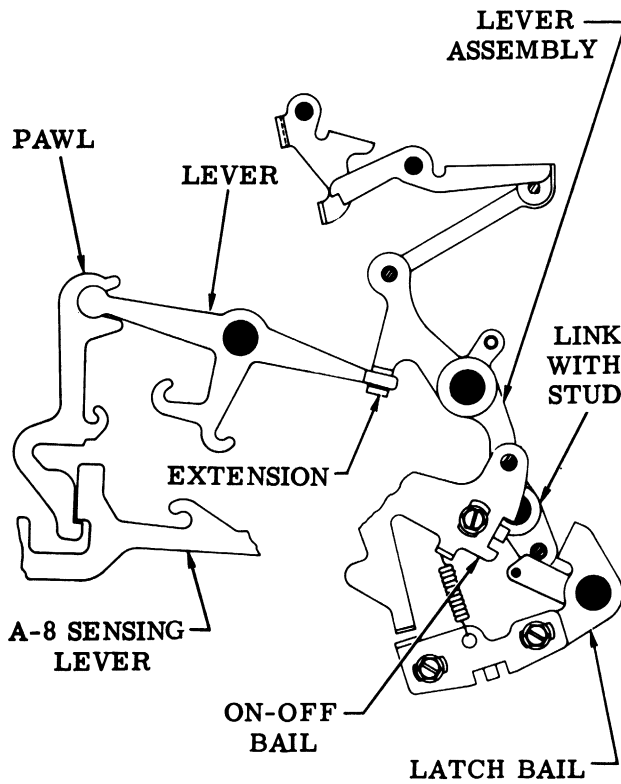

(Left Side View)

Figure 12 - Automatic ON Mechanism

code combination is set up in the typing unit codebars and codebar extensions. The A-0 sensing lever senses the codebar extensions and positions a pawl and lever. The lever has an extension which causes the post of the ON-OFF bail to move upward. Simultaneously, the stud engages the feed pawl and pulls it down disengaging it from the feed wheel ratchet. The ON-OFF bail lever drops in the engaging surface of the spring biased latch bail. During subsequent cycles, the sensing levers will sense incoming code combinations but the selected pawls will be stripped each time. Likewise, there will be no action of the feed pawl and the tape will not be advanced.

**VARIABLE FEATURES**

**5.13 Tape Punch Interlock** - When the typing unit is in a nonprint condition, the nonprint codebar connects to a post on the right side of the latch bail and cams it in a counterclockwise direction. This action turns the tape punch on and prevents it from being turned off as long as the codebar remains in the nonprint mode. When the nonprint codebar is not in the nonprint mode, the ON-OFF mechanism returns to its normal condition.

**5.14 ON-LOCK** - This variable feature consists of an ON-LOCK pushbutton on the tape punch cover which, when depressed, locks the ON lever so that the OFF lever is disabled and cannot be operated. The tape punch will be on as long as the ON-LOCK pushbutton is held down.

**5.15 UNLOCK** - This variable feature consists of an UNLOCK pushbutton on the tape punch cover which, when depressed, removes the locked condition described in 5.14. Depressing the UNLOCK pushbutton will not turn the tape punch off, but will allow the tape punch to accept an OFF signal. It will then be able to turn off automatically.

**5.16 Code Option** - The codebar extensions may be coded with various code combinations to turn the tape punch on or off. For the ON mode the no. 7 bit should be a spacing bit so no interference will occur between the no. 7

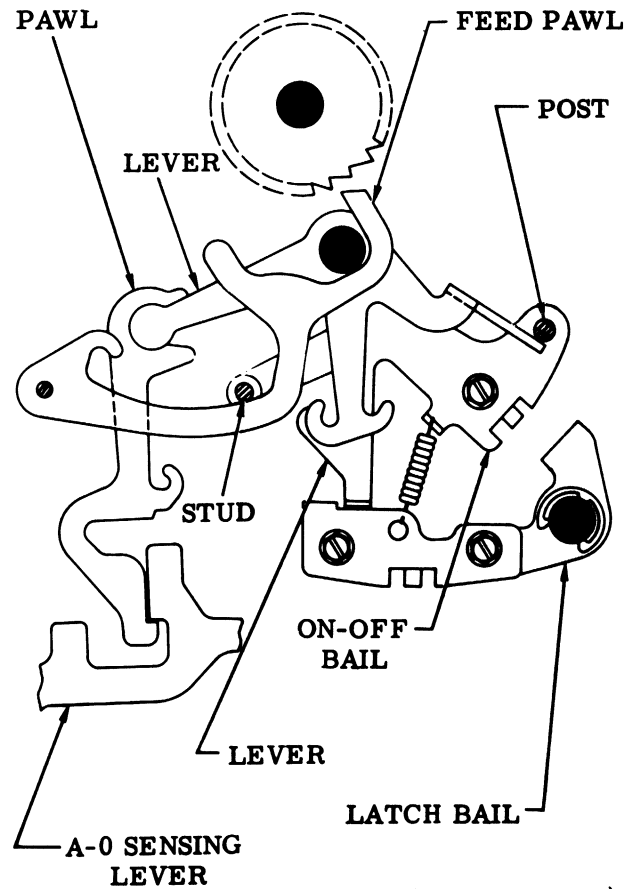

(Left Side View)

Figure 13 - Automatic OFF Mechanism

## SECTION 574-125-100TC

codebar extension tab and no. 7 sensing lever tab.

5.17 Visual ON-OFF Indicator - The indicator mounts on the ON and OFF lever mounting post and protrudes through the surface of the cover. The OFF lever positions the indicator; when the OFF lever is down it moves the indicator to the OFF position, when it is up it moves the indicator to the ON position.

5.18 Noncontention - In Automatic Send Receive (ASR) teletypewriter sets equipped with the noncontention mechanism an additional codebar and codebar extension operate to allow the tape punch to be turned on or off. When the ASR set is transmitting, the noncontention codebar is marking. When the ASR set is receiving, the noncontention codebar is spacing. When the ASR set is transmitting, the

codebar extension blocks all the sensing levers in the tape punch. This prevents from turning it on or off automatically, although it could be turned on or off manually. When the ASR set is receiving, the sensing levers are permitted to sense any incoming code and the tape punch can be turned on or off if the proper code is received. Again the tape punch could be turned on or off manually as well.

5.19 E. O. T. - The tape punch can be turned off when the end of transmission code is selected. The A-0 sensing lever is coded to read the E. O. T. code combination and will originate the motion to turn the tape punch off as described in 5.12.

5.20 Sense Suppression - This mechanism blocks the sensing levers from sensing when the tape punch is off.

33 TAPE PUNCH

LUBRICATION

CONTENTS	PAGE
1. GENERAL . . . . .	1
2. BASIC UNIT . . . . .	2
Backspace lever . . . . .	8
Codebar levers . . . . .	5
Control mechanism . . . . .	5
Detent lever . . . . .	8
Drive link mechanism area . . . . .	2
Drive link mechanism (Early design) . . . . .	3
Drive link mechanism (Late design) . . . . .	3
Feed mechanism . . . . .	7
Feed pawl . . . . .	7
Pawls and levers . . . . .	6
Punch block assembly . . . . .	9
Sensing levers . . . . .	6
Stripper bail . . . . .	6
Support link (Late design) . . . . .	3
Tape guide assembly . . . . .	8
Tape guide roller . . . . .	9
Tape punch . . . . .	4
3. VARIATIONS TO THE BASIC UNIT . . . . .	10
Automatic on-off bail drive lever . . . . .	11
Automatic on-off control bail . . . . .	11
Automatic on-off control levers . . . . .	12
Automatic on-off control mechanisms . . . . .	13
Automatic tape punch . . . . .	10
LOCK "ON" mechanism . . . . .	14
Punch interlock mechanism . . . . .	14
Sense suppression mechanism . . . . .	15

1. GENERAL

1.01 This section provides lubrication requirements for the 33 tape punch. It is reissued to incorporate engineering changes, rearrange the text, and add coverage of automatic punch features. Since this is a general revision, marginal arrows, ordinarily used to indicate changes and addition, are omitted.

1.02 The general lubrication areas are illustrated by photographs. The specific points to receive lubricant are indicated on line drawings with appropriate textual instructions. Line drawings and textual instructions follow each photograph and are keyed to the photograph by paragraph numbers.

1.03 Thoroughly lubricate the tape punch, but avoid overlubrication that might permit the lubricant to drip or be thrown onto adjacent parts. Saturate all felt washers and oilers with oil.

1.04 Lubricate the tape punch before placing it into service or prior to storage. After a short period of service, relubricate it to make sure no areas have been missed. Thereafter, lubricate the tape punch at regular intervals as indicated below:

<u>Operating Speed</u> (Words per Minute)	<u>Lubrication</u> <u>Interval</u>
100	500 hours* or 6 months**

\*Station set operating hours.  
 \*\*Whichever comes first.

1.05 The textual instructions that accompany the line drawings consist of abbreviated directions specific lubrication points, and parts affected. The meanings of the abbreviated directions (symbols) are given below.

<u>Symbol</u>	<u>Meaning</u>
D	Keep dry — no lubricant permitted.
O	Oil (KS7470).

1.06 References to left, right, front, or rear, etc consider the tape punch to be viewed from a position where the tape guide assembly faces up and the backspace lever is to the viewer's left. Orientation references in the drive link mechanism area consider the drive link to be up and located to the viewer's left.

SECTION 574-125-701TC

CAUTION: DO NOT USE ALCOHOL, MINERAL SPIRITS, OR OTHER SOLVENTS TO CLEAN PLASTIC PARTS OR PARTS WITH PROTECTIVE-DECORATIVE FINISHES. NORMALLY, A SOFT, DRY CLOTH SHOULD BE USED TO REMOVE DUST, OIL, GREASE, OR OTHERWISE CLEAN PARTS OR SUBASSEMBLIES. IF NECESSARY, A SOFT CLOTH DAMPENED WITH SOAP OR MILD DETERGENT MAY BE USED. AFTERWARDS,

RINSE EACH CLEANED PART OF SUBASSEMBLY WITH A SOFT, DAMP CLOTH AND BUFF WITH A SOFT, DRY CLOTH.

1.07 Tools and materials needed for teletypewriter lubrication are listed in Section 570-005-800TC.

1.08 For disassembly and reassembly information refer to Section 574-125-702TC.

2. BASIC UNIT

2.01 Drive link Mechanism Area

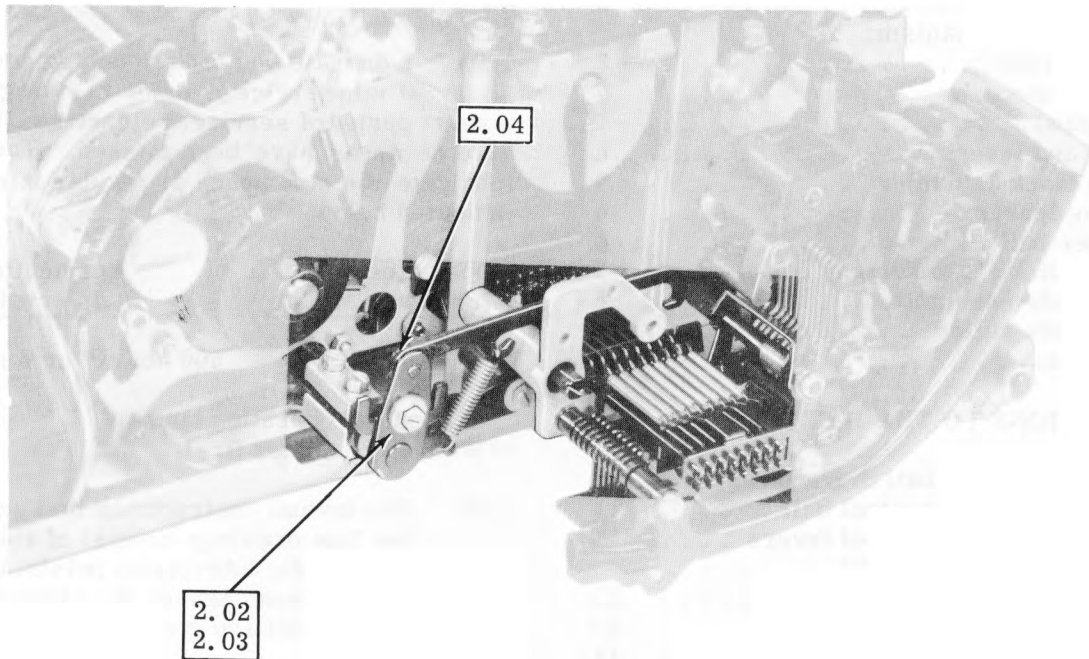

(Left Side View)

2.02 Drive Link Mechanism (Early Design)

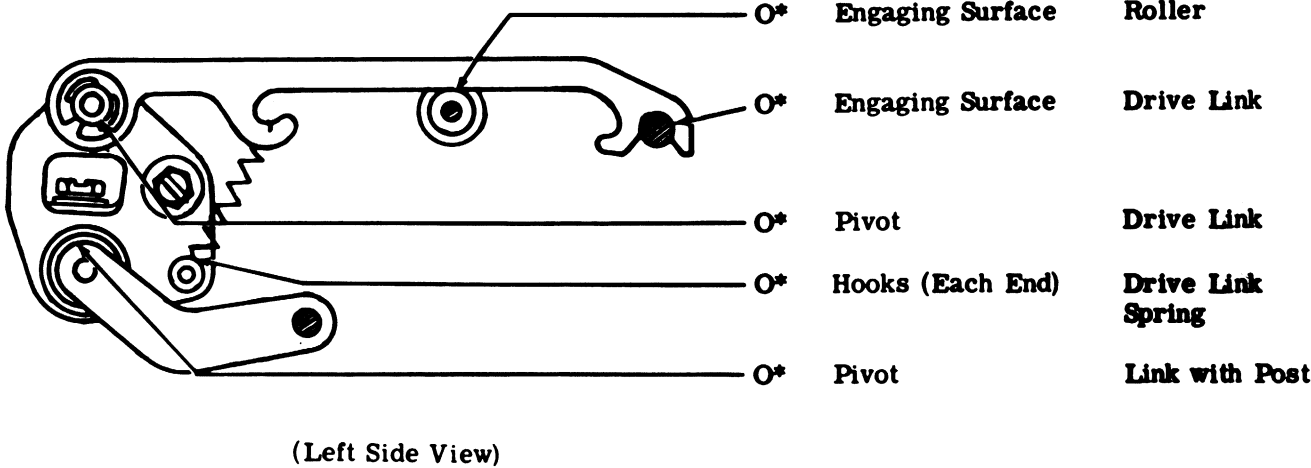

2.03 Drive Link Mechanism (Late Design)

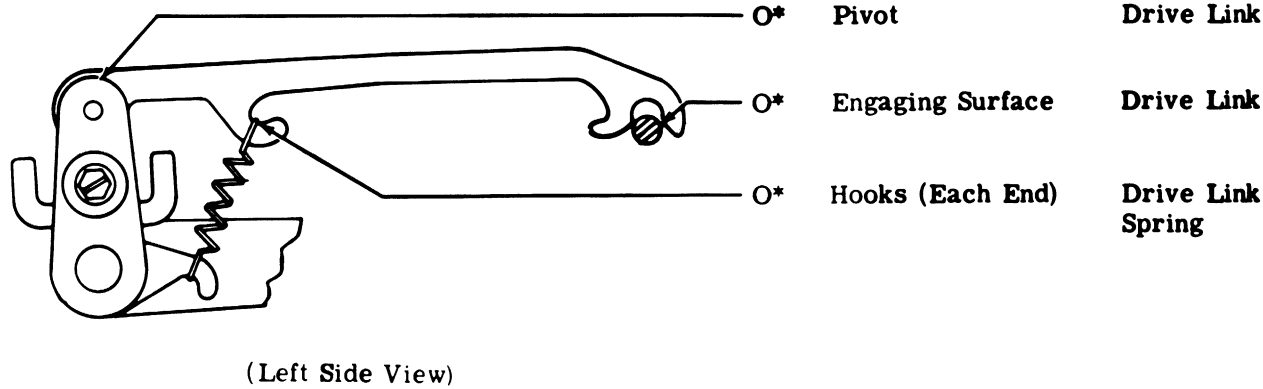

2.04 Support Link (Late Design)

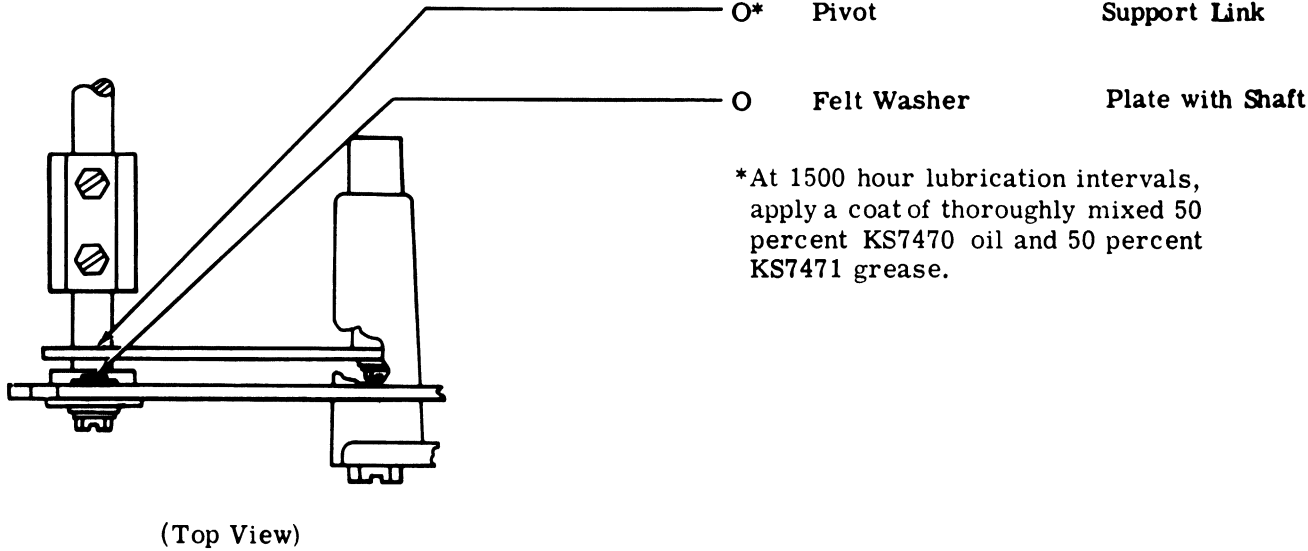



SECTION 574-125-701TC

2.05 Tape Punch

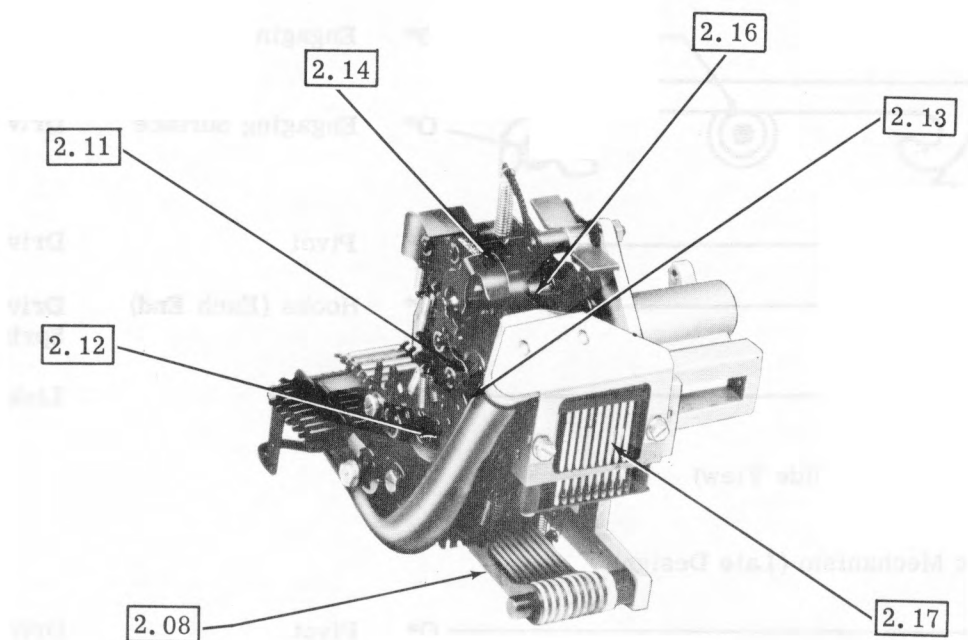

(Left Front View)

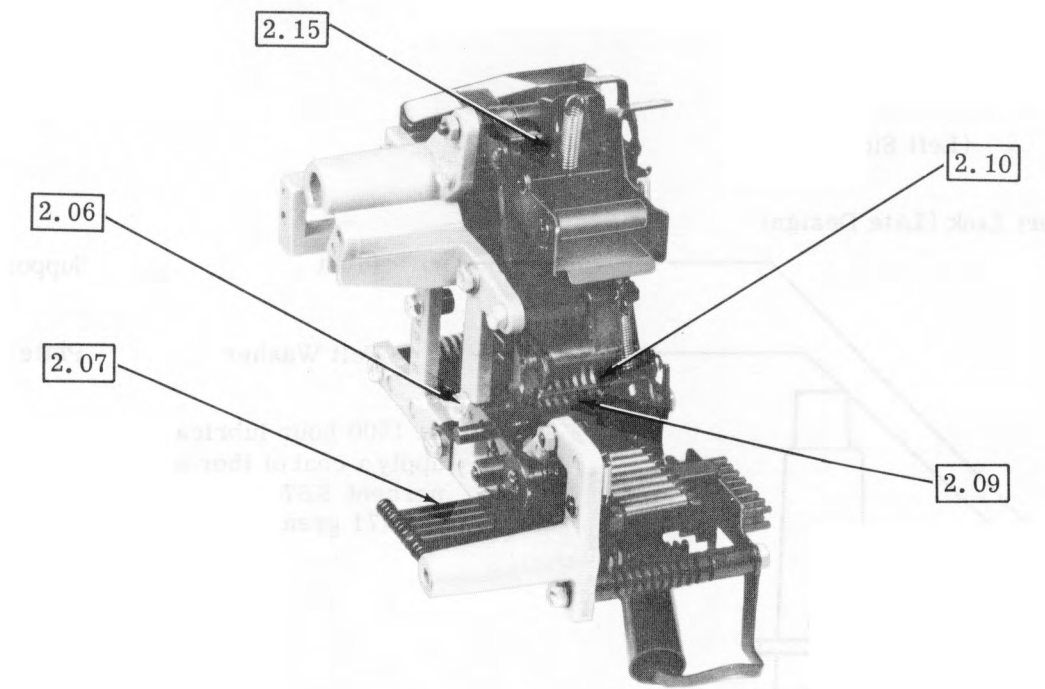

(Right Rear View)

2.06 Control Mechanism

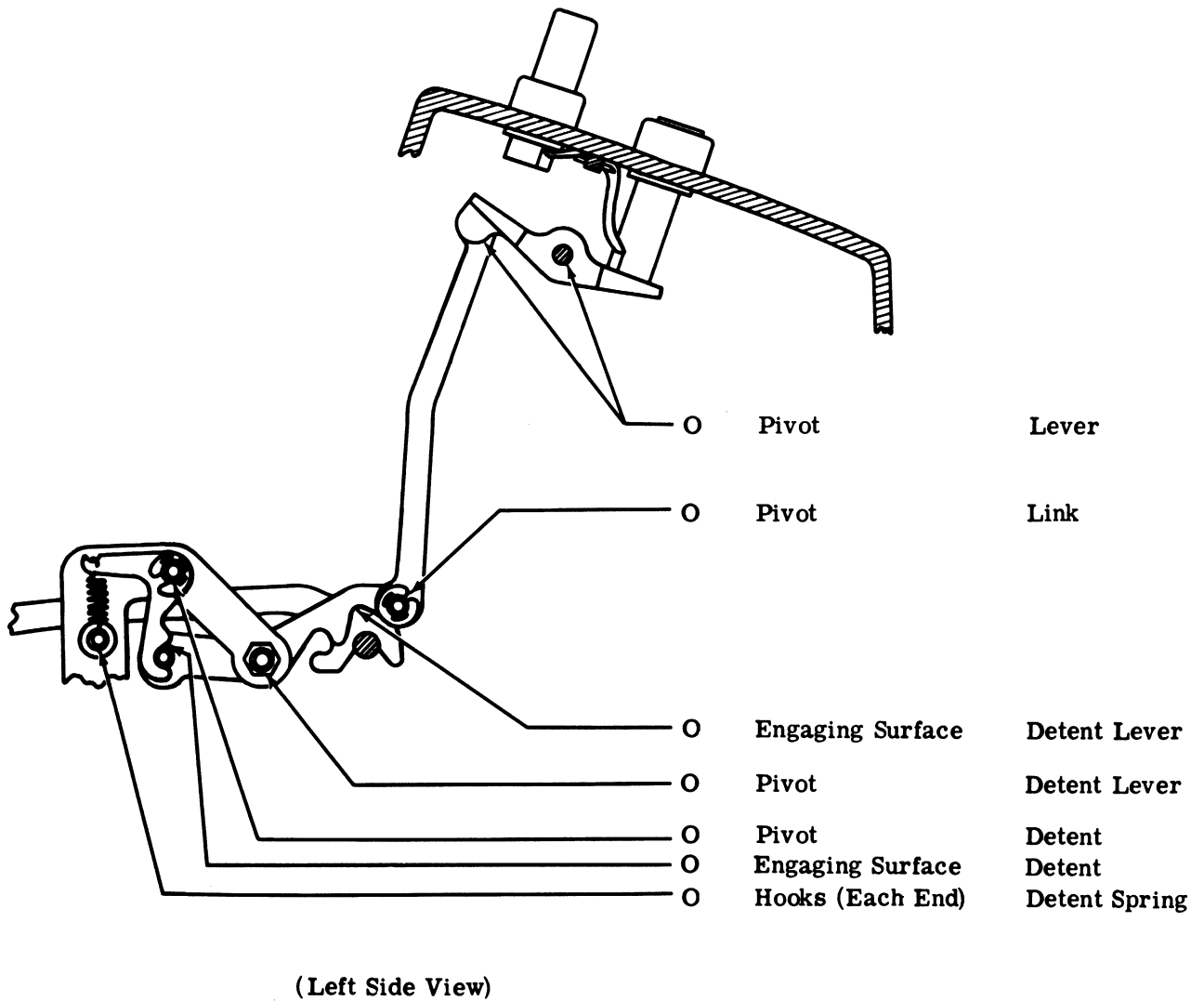

2.07 Codebar Levers

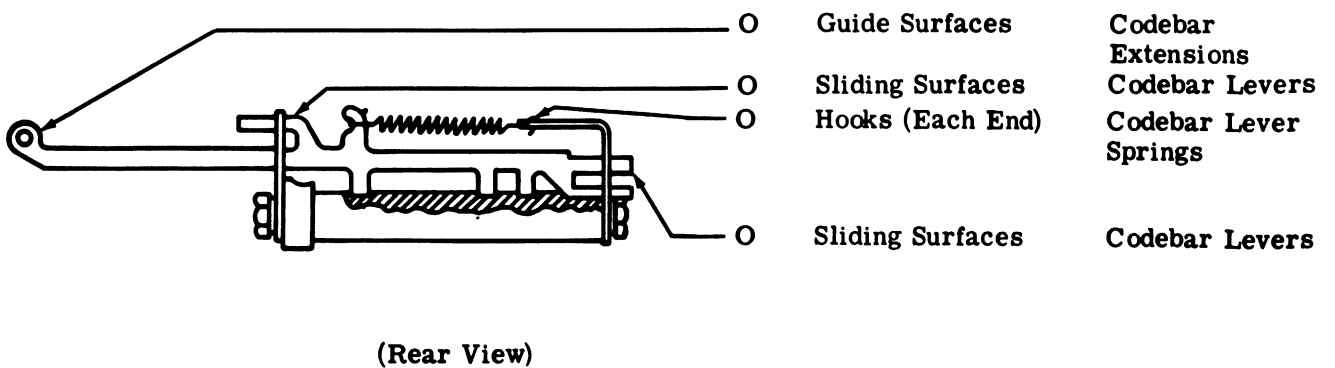

2.08 Sensing Levers

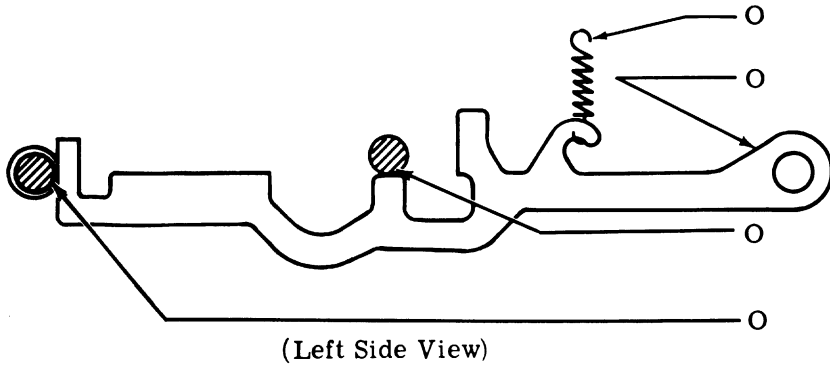

- Hooks (Each End)
- Felt Washers
- Sliding Surface
- Sliding Surfaces
- Sensing Lever Springs
- Sensing Levers
- Sensing Levers
- Sensing Levers

2.09 Stripper Bail

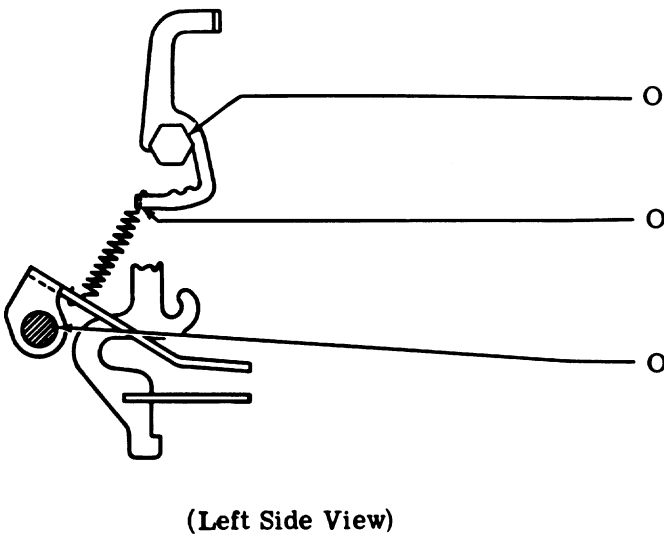

- Pivot
- Hooks (Each End)
- Pivot (Torsion Spring, Late Design)
- Hook
- Stripper Bail Spring (Early Design Only)
- Stripper Bail

2.10 Pawls and Levers

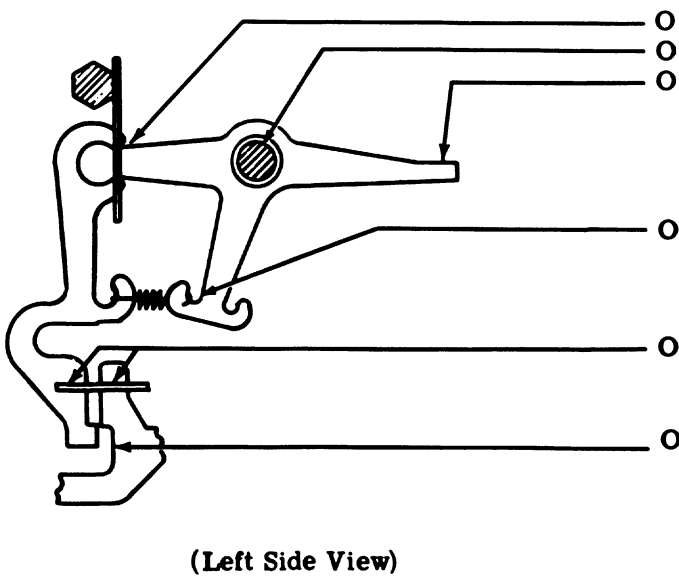

- Sliding Surfaces
- Felt Washers
- Engaging Surfaces
- Hooks (Each End)
- Sliding Surfaces
- Engaging Surfaces
- Pawls and Levers
- Lever Pivot
- Levers
- Pawl and Lever Springs
- Pawls and Sensing Levers
- Pawls and Sensing Lever

2.11 Feed Mechanism

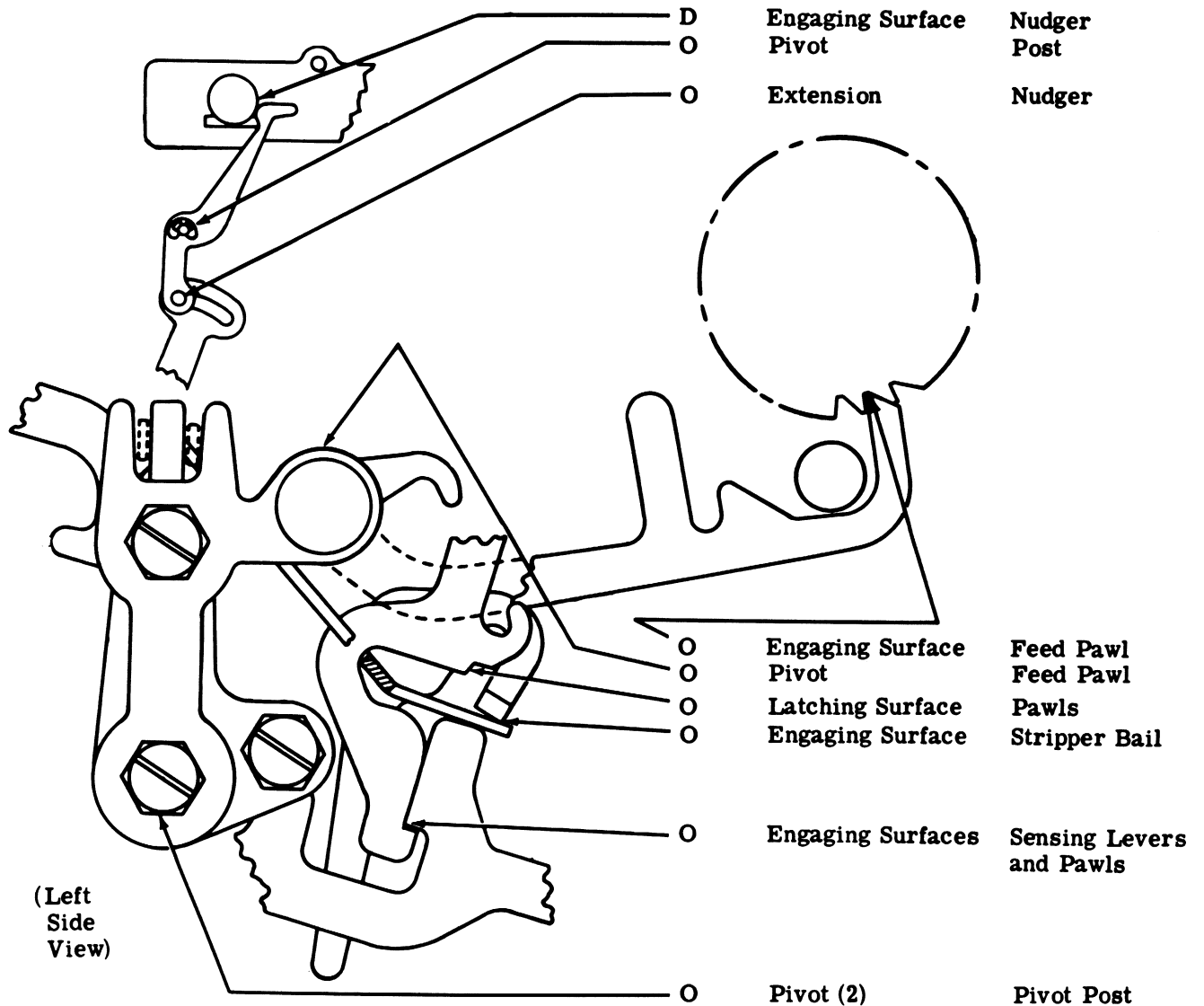

2.12 Feed Pawl

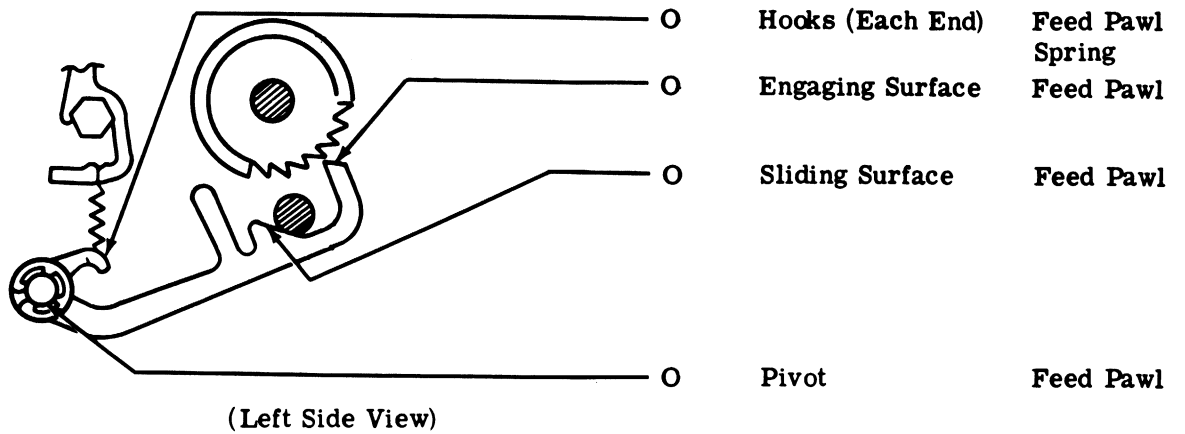

**SECTION 574-125-701TC**

**2.13 Detent Lever**

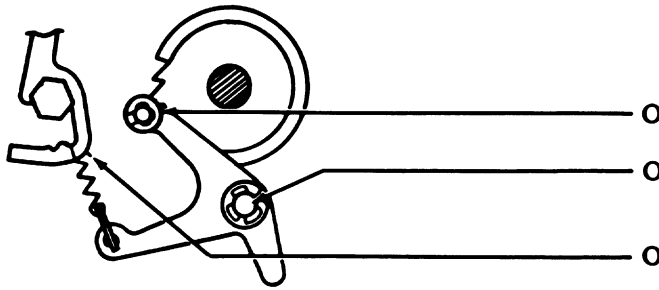

- |   |                  |                     |
|---|------------------|---------------------|
| O | Roller           | Detent Lever        |
| O | Pivot            | Detent Lever Shaft  |
| O | Hooks (Each End) | Detent Lever Spring |

(Left Side View)

**2.14 Backspace Lever**

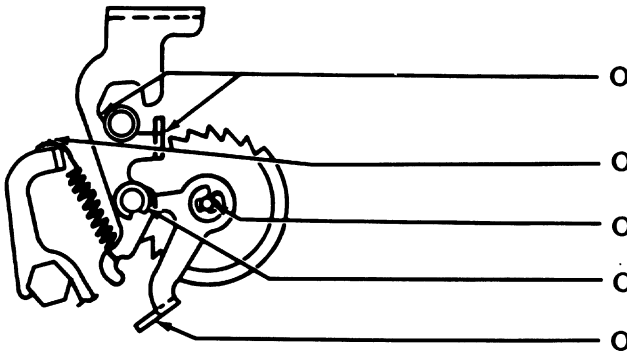

- |   |                  |                        |
|---|------------------|------------------------|
| O | Sliding Surface  | Backspace Lever        |
| O | Hooks (Each End) | Backspace Lever Spring |
| O | Pivot            | Lever                  |
| O | Pivot            | Lever                  |
| O | Engaging Surface | Lever Extension        |

(Left Side View)

**2.15 Tape Guide Assembly**

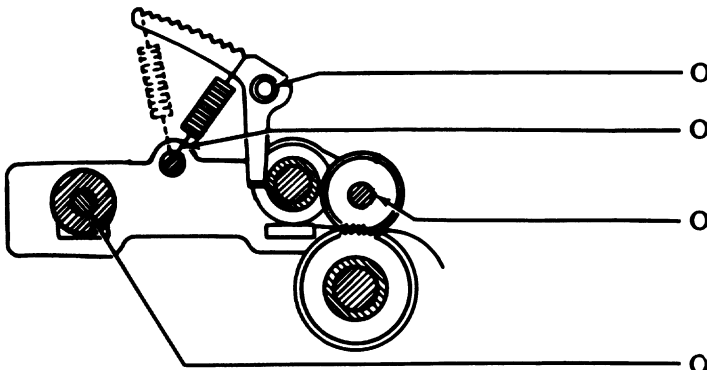

- |   |                   |                          |
|---|-------------------|--------------------------|
| O | Pivot             | Arm w/Bushing            |
| O | Hooks (Each End)  | Tape Guide Roller Spring |
| O | Shaft (Both Ends) | Roller                   |
| O | Pivots (2)        | Rear Roller              |

(Left Side View)

2.16 Tape Guide Roller

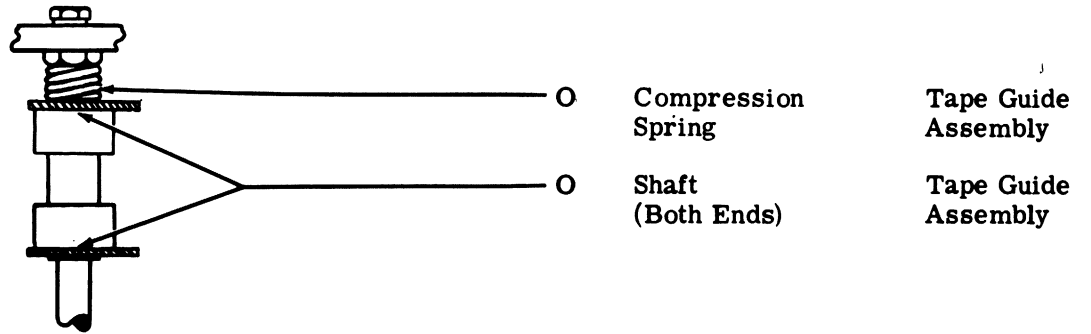

(Top View)

2.17 Punch Block Assembly

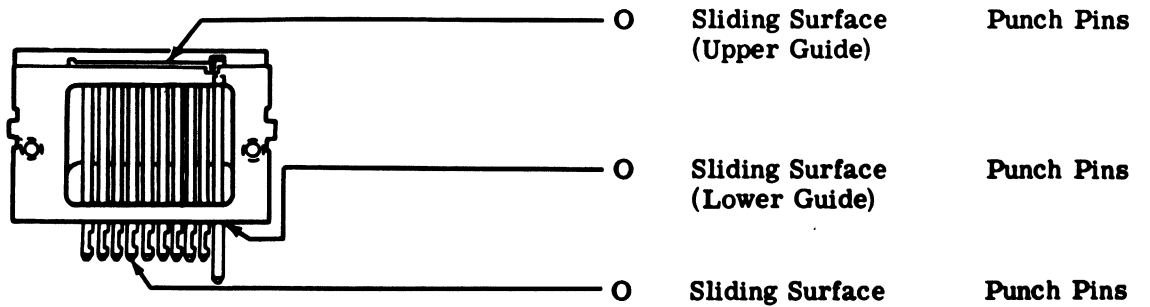

(Front View)

3. VARIATIONS TO THE BASIC UNIT

3.01 Automatic Tape Punch

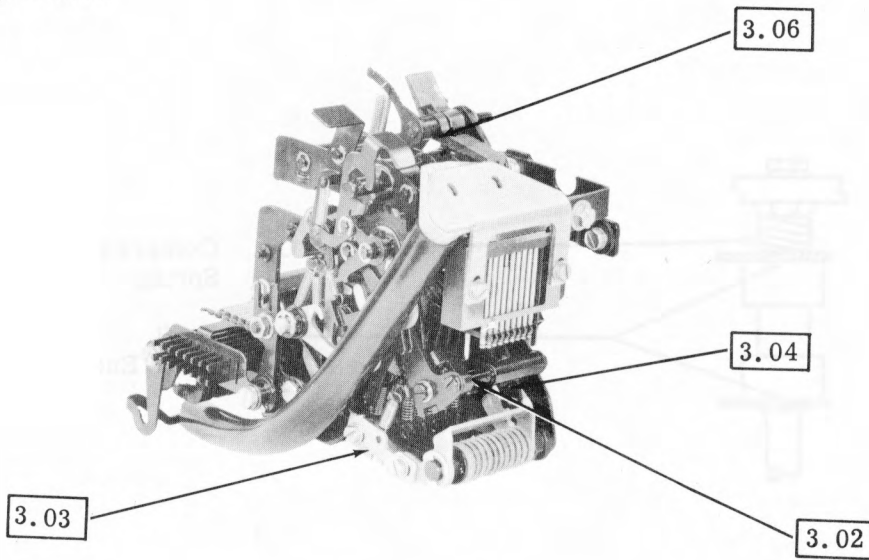

(Left Front View)

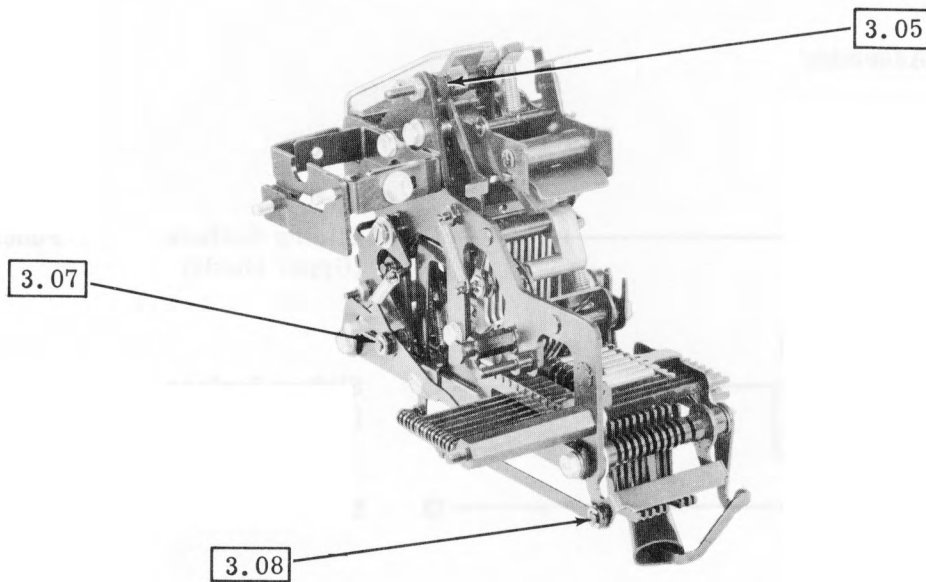

(Right Front View)

3.02 Automatic On-Off Bail Drive Lever

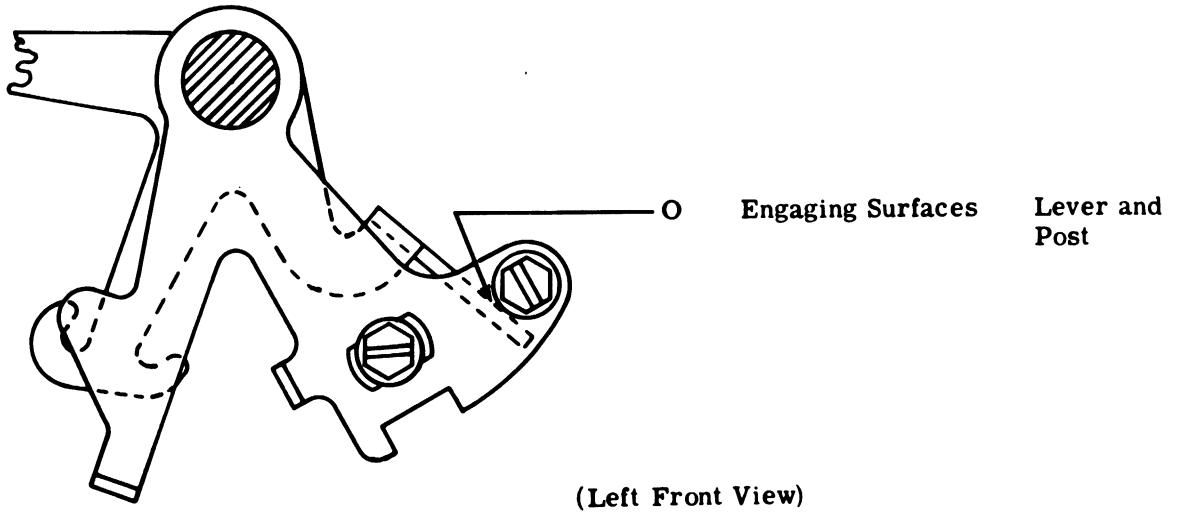

3.03 Automatic On-Off Control Bail

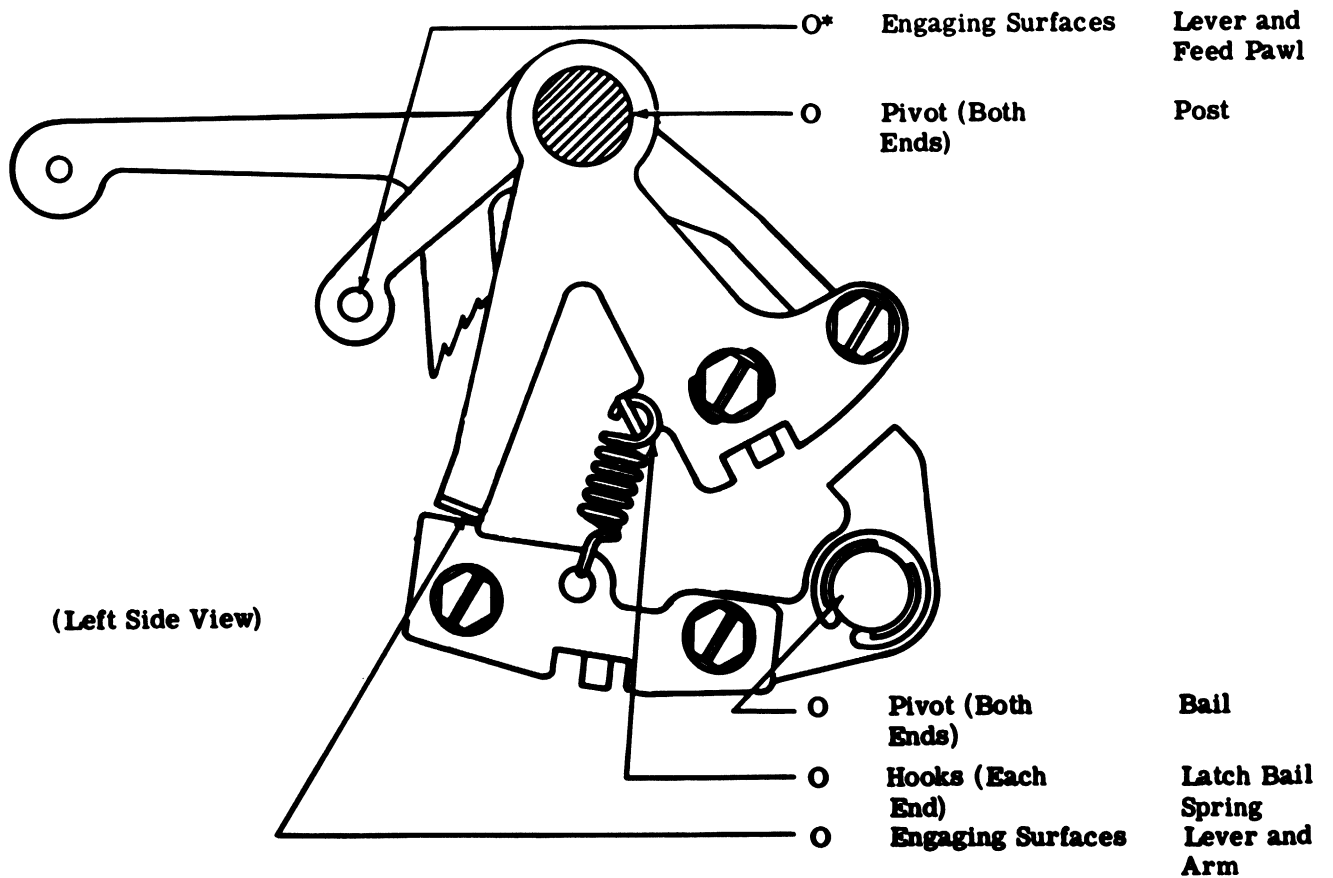

\*At 1500 hour lubrication intervals, apply a coat of thoroughly mixed 50 percent KS7470 oil and 50 percent KS7471 grease.



3.04 Automatic On-Off Control Levers

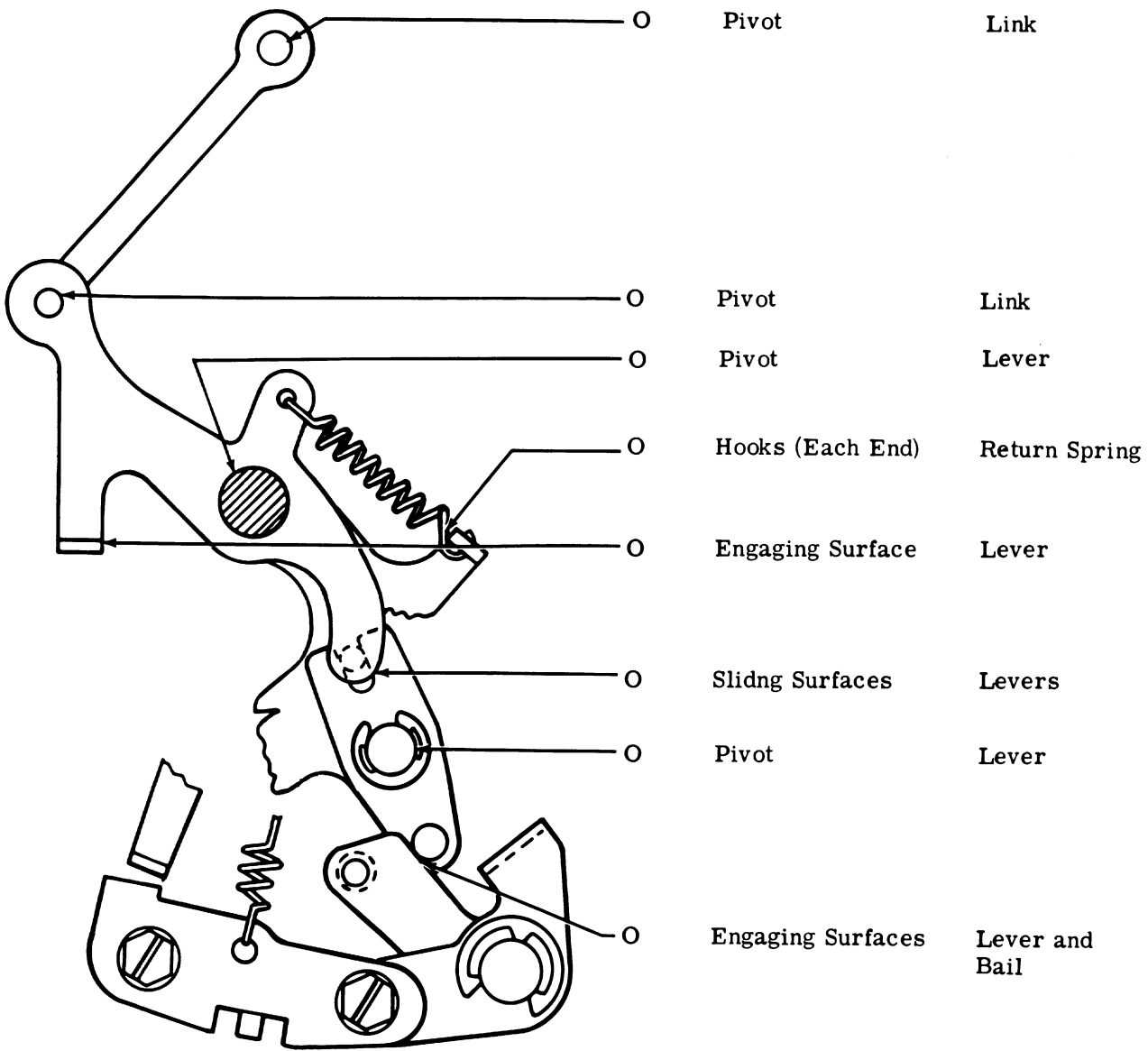

(Left Side View)

3.05 Automatic On-Off Control Mechanisms

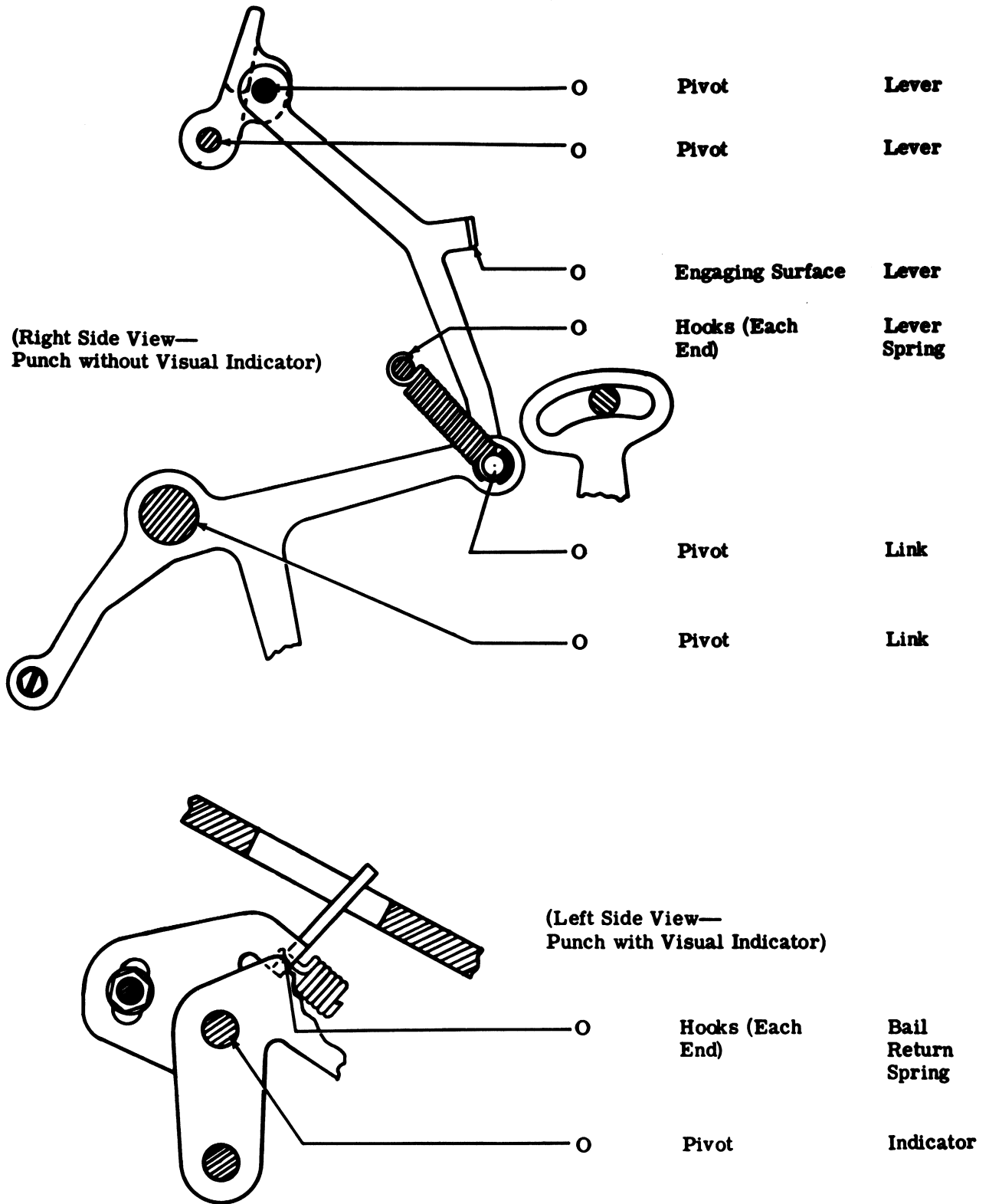

SECTION 574-125-701TC

3.06 LOCK "ON" Mechanism

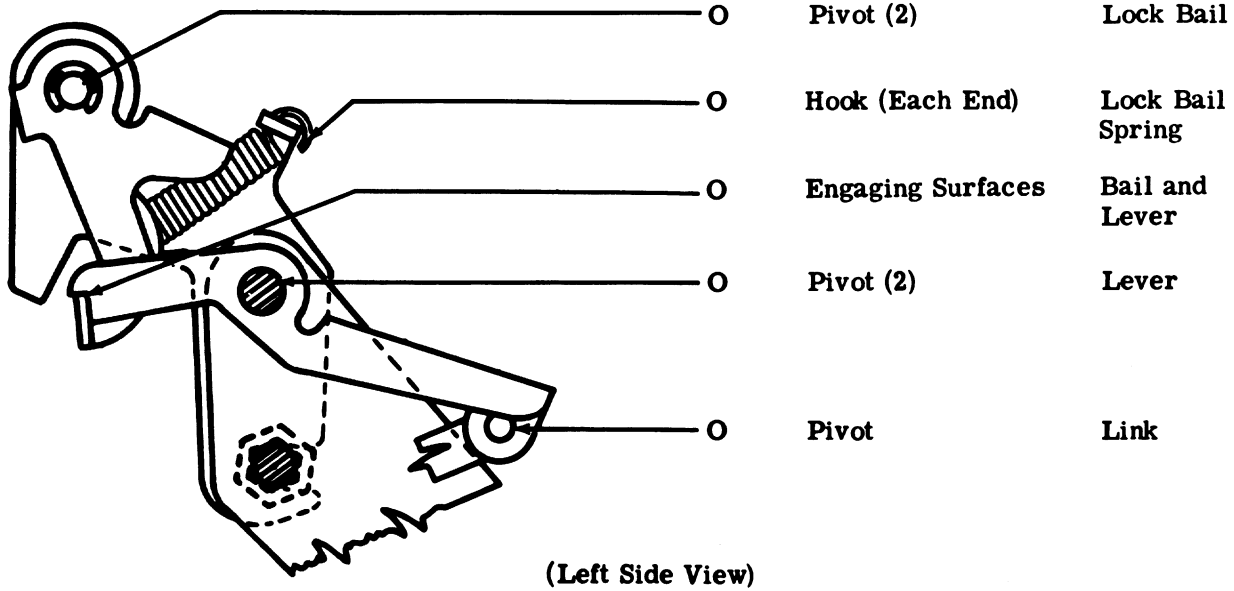

3.07 Punch Interlock Mechanism

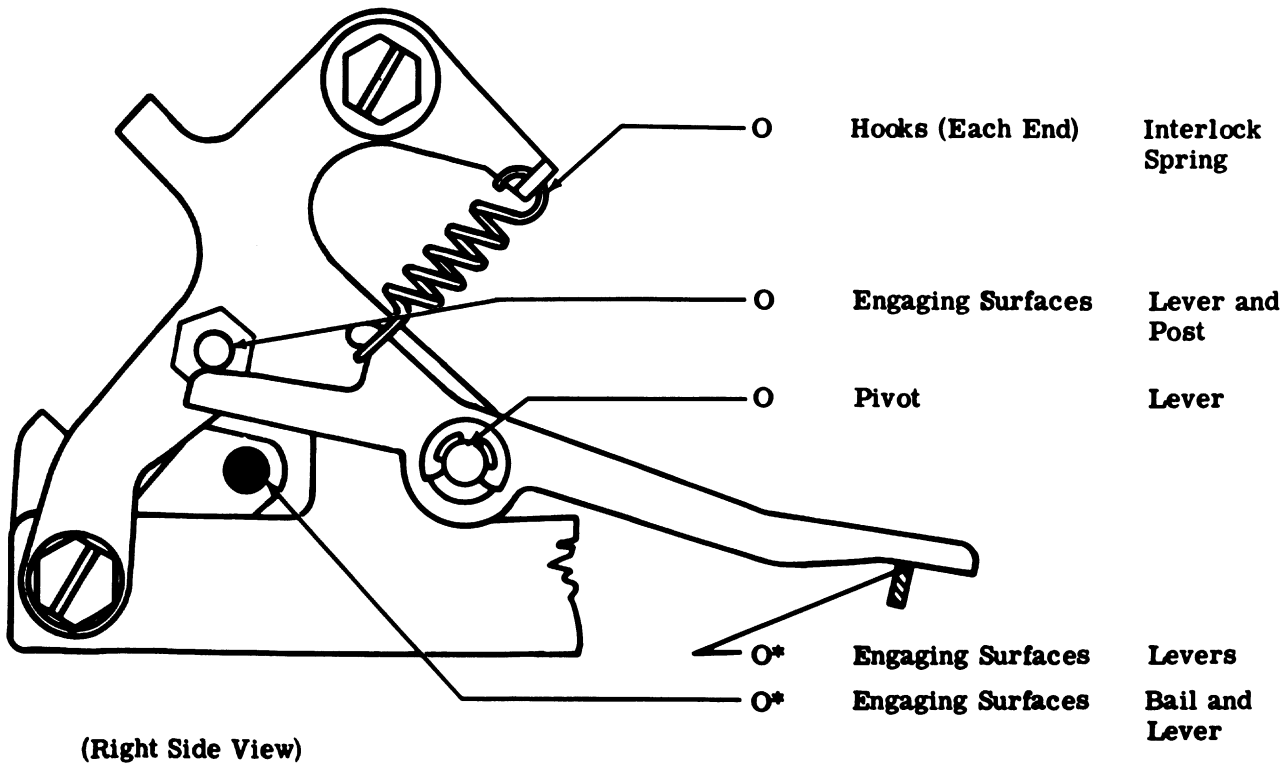

\*At 1500 hour lubrication intervals, apply a coat of thoroughly mixed 50 percent KS7470 oil and 50 percent KS7471 grease.

3.08 Sense Suppression Mechanism

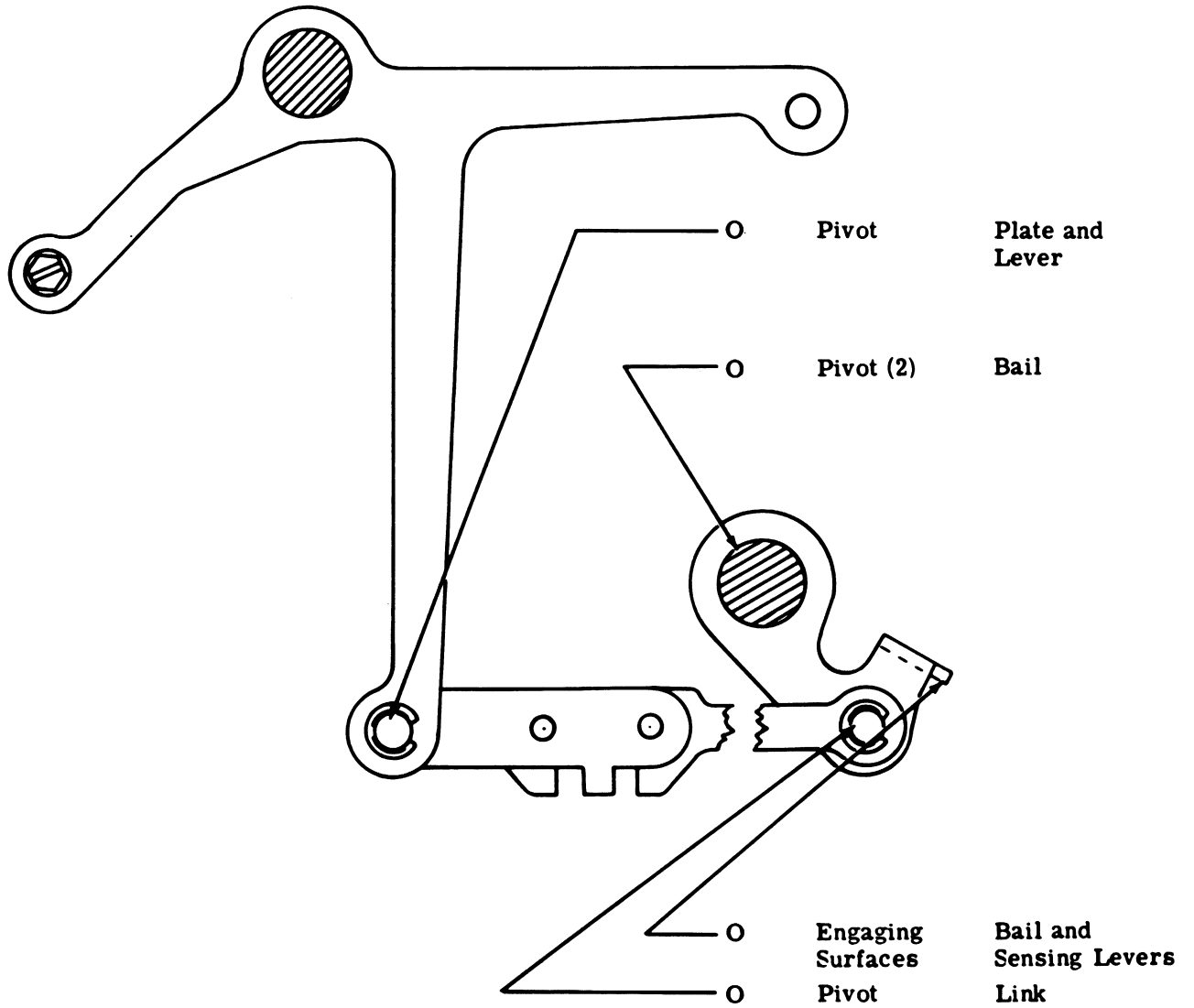

(Right Side View)



33 TAPE PUNCH

DISASSEMBLY AND REASSEMBLY

CONTENTS	PAGE
1. GENERAL . . . . .	1
2. DISASSEMBLY AND REASSEMBLY . .	1
CHAD CHUTE ASSEMBLY . . . . .	1
PUNCH BLOCK ASSEMBLY . . . . .	2
A. Early Design . . . . .	2
B. Late Design . . . . .	2
TAPE GUIDE ASSEMBLY . . . . .	3
PAWL UPSTOP ASSEMBLY . . . . .	3
SENSING LEVERS AND GUIDEPLATE ASSEMBLY . . . . .	4
PAWL, LEVER, AND SPRING COMBINATIONS . . . . .	4

1. GENERAL

1.01 This section is reissued to incorporate all recent engineering changes and to present disassembly and reassembly information exclusively for the 33 tape punch. Since this is a general revision, marginal arrows, used to indicate changes, have been omitted.

1.02 References to left, right, front, rear, etc, consider the tape punch to be viewed from a position where tape guide assembly faces up and the backspace lever is to the viewer's left. Orientation references in the drive link mechanism area consider the drive link to be up and located to the viewer's right.

1.03 Disassembly, as outlined in this section, covers the procedure for removing the principle subassemblies which make up the unit. If further disassembly is required, refer to Section 574-125-800TC, which shows detailed arrangement of parts. Where it will help in deter-

mining their location, the numbers of the parts are given in the instructions.

1.04 When self-tapping screws are used to mount mechanisms onto castings, do not remove the self-tapping screws. Merely loosen them enough to remove the mechanisms unless specifically instructed otherwise.

1.05 Retaining rings are made of spring steel and have a tendency to release suddenly. To avoid loss of these rings when removing them, proceed as follows.

- (a) Hold retaining ring to prevent its rotating.
- (b) Place blade of screwdriver in one of ring's slots and rotate screwdriver to increase diameter.
- (c) Ring will come off easily in fingers without flying.

1.06 All tools used to remove the mechanisms referred to in this section can be found in the 570-005-800TC standard tool section. No additional special tools are required.

1.07 All damaged, worn, or distorted parts should be replaced if encountered in the disassembly and reassembly procedures.

2. DISASSEMBLY AND REASSEMBLY

Note: For information concerning the proper procedure to remove the tape punch from the set, refer to the set disassembly and reassembly section, 574-100-702TC.

CAUTION: BEFORE BEGINNING DISASSEMBLY, REMOVE CONNECTORS FROM EXTERNAL RECEPTACLES (POWER SOURCE, DATA SET, ETC).

CHAD CHUTE ASSEMBLY

2.01 To remove the chad chute assembly (Figures 1 and 3), proceed as follows.

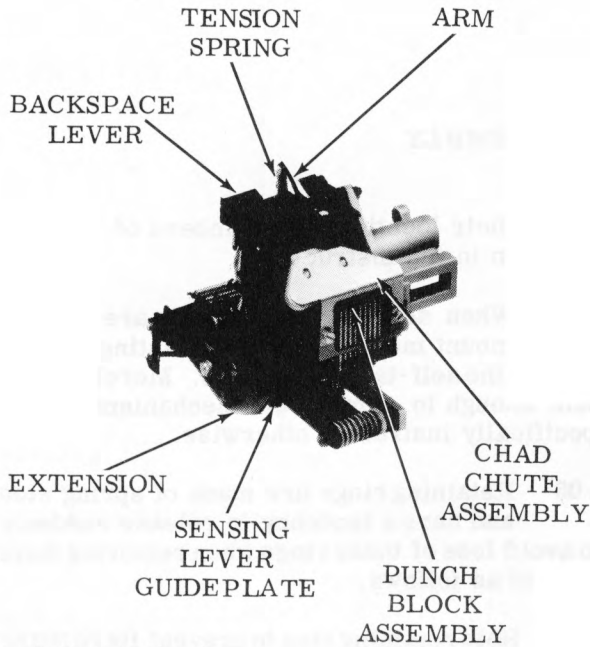

(Left Front View)

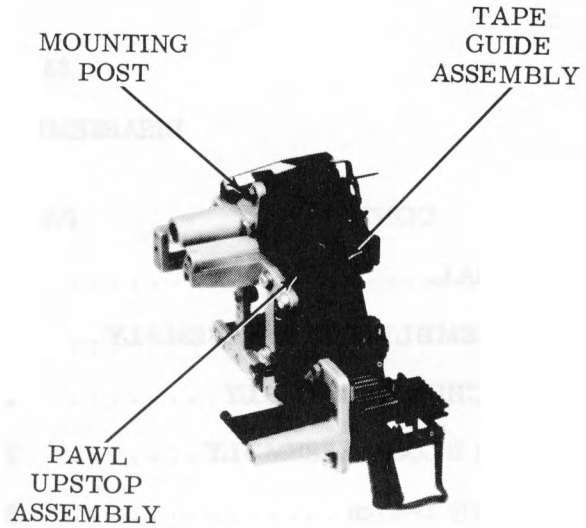

(Right Rear View)

Figure 1 - Tape Punch (Cover Removed, Early Design)

Figure 2 - Tape Punch (Cover Removed, Early Design)

- (a) Remove the TP182915 extension.
- (b) Remove two TP152893 screws, TP110743 lockwashers, and TP2034 flat washers.
- (c) Remove the TP182908 chad chute assembly.
- (d) To replace the chad chute assembly, reverse the procedure used to remove it. Line up the oblong holes of the plate with the holes in the punch block holder. Apply finger pressure on top of the chad chute assembly towards punch block holder when replacing and tightening the two screws.

Note: Late design units have a TP185891 plastic chad chute assembly that should not be removed.

#### PUNCH BLOCK ASSEMBLY

##### A. Early Design

2.02 To remove the punch block assembly (Figure 1), proceed as follows.

- (a) Remove the two TP153817 mounting screws, TP110743 lockwashers, and TP2034 flat washers.

- (b) Slide the punch block assembly forward until the tongue in the punch block holder and the punch pins disengage the groove in the TP182903 tape punch casting and the TP182813 levers respectively.

- (c) To replace the punch block assembly, position the slots in the punch pins so that they face the guide pin. The bottom of the punch pins should be in line and in a position that approximates their position when on the tape punch. Line up the punch pin slots with their levers and reverse the procedure used to remove the punch block assembly.

##### B. Late Design

2.03 To remove punch block assembly (Figures 3 and 4), proceed as follows.

- (a) Remove the three TP153817 screws, TP110743 lockwashers, and TP2034 flat washers.
- (b) Slide the punch block assembly forward until the tongue in the punch block holder and the punch pins disengage the groove in the TP182903 tape punch casting and the TP182813 levers respectively.

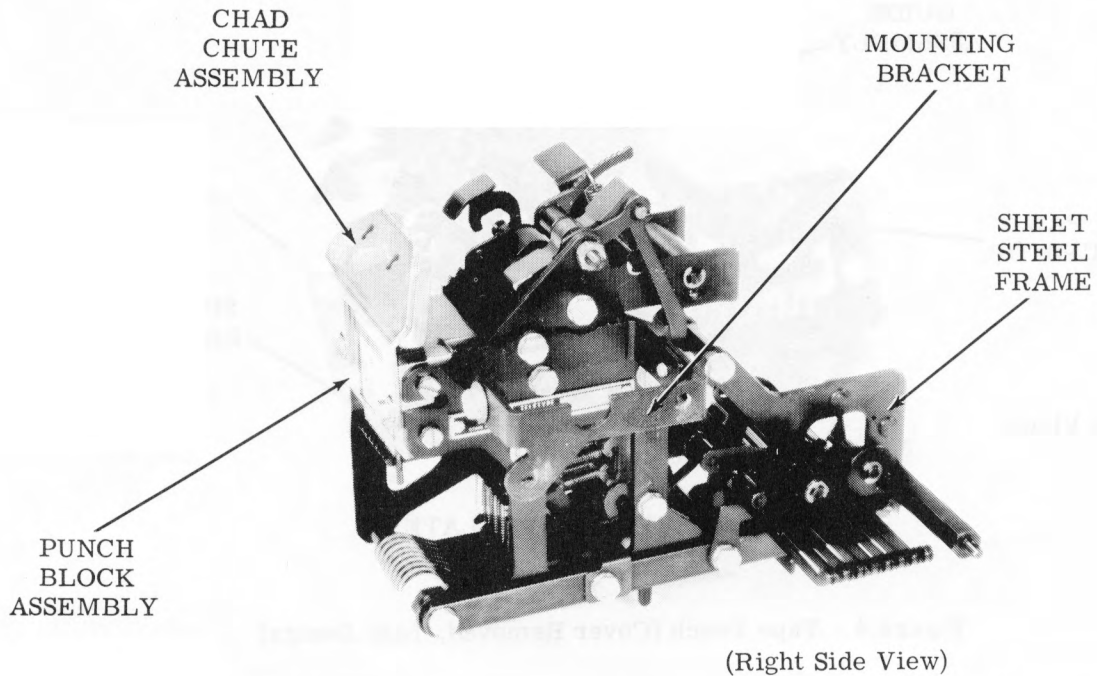

Figure 3 - Tape Punch (Cover Removed, Late Design)

(c) To replace the punch block assembly, position the slots in the punch pins so that they face the guide pin. The bottom of the punch pins should be in line and in a position that approximates their position when on the tape punch. Line up the punch pin slots with their levers and reverse the procedure used to remove the punch block assembly.

#### TAPE GUIDE ASSEMBLY

2.04 To remove the tape guide assembly (Figures 2 and 4), proceed as follows.

- (a) With a pencil or suitable marking instrument, mark the notch where the TP184095 tension spring end is positioned.
- (b) Unhook the TP184095 tension spring and remove the TP182936 arm from the TP182845 post.
- (c) Remove the TP181244 mounting screw from the tape guide assembly.

(d) Remove the tape guide assembly.

(e) To replace the tape guide assembly, reverse the above procedure making sure that the tension spring is positioned in the marked notch of the arm.

#### PAWL UPSTOP ASSEMBLY

2.05 To remove the pawl upstop assembly (Figures 2 and 4), proceed as follows.

Note: Never disassemble the pawl upstop assembly prior to removing the pawl, lever, and spring combinations. The slotted TP182822 plate keeps the "ball" and "socket" of the lever and pawl in full engagement.

- (a) Remove the TP181244 screw.
- (b) Remove the TP182821 post, TP182893 bracket, and TP182822 plate.
- (c) To replace the pawl upstop assembly, reverse the procedure used to remove it.



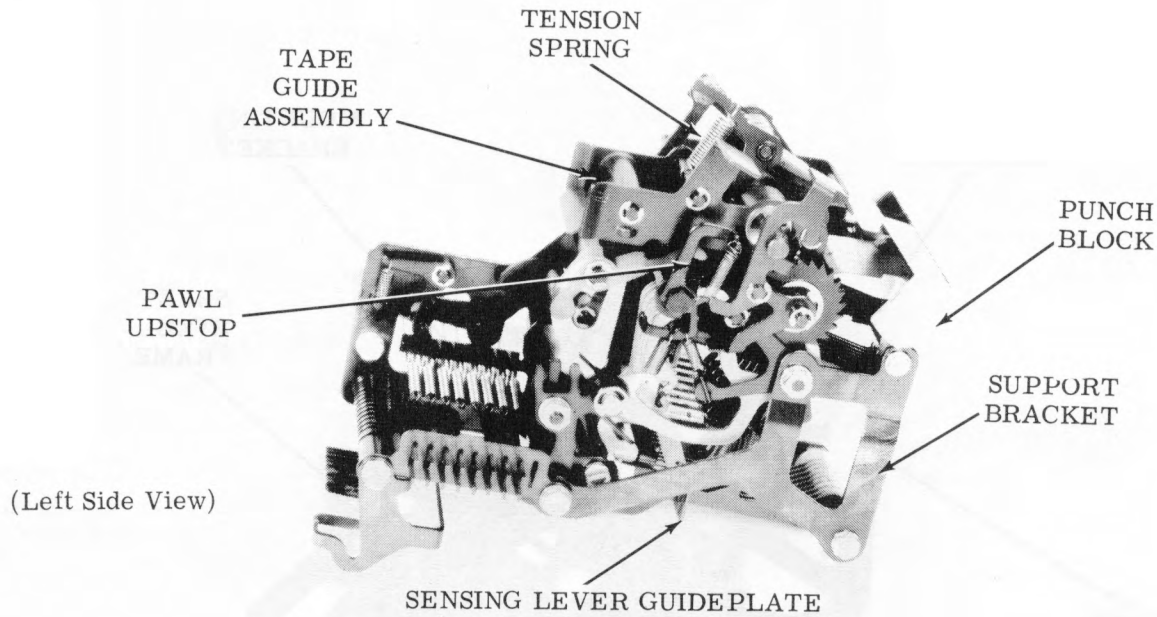

Figure 4 - Tape Punch (Cover Removed, Late Design)

#### SENSING LEVERS AND GUIDEPLATE ASSEMBLY

2.06 To remove the sensing levers and guideplate assembly (Figures 1 and 4), proceed as follows.

- (a) Unhook each TP182909 sensing lever spring and rotate each sensing lever away from the guideplate.
- (b) Remove the two TP181244 screws from the TP185847 post and remove the post and the attached sensing levers.
- (c) Remove the TP181242 screw and TP3598 nut from the TP182815 guideplate. Remove the guideplate.
- (d) To replace the sensing levers and guideplate, reverse the procedure used to remove them. However, before tightening the TP181242 screw and TP3598 nut, push the guideplate downward to take up all play. Viewing the tape punch from the left, position the guideplate in a horizontal to a slightly counterclockwise from horizontal position as gauged by eye. Then, tighten the TP181242 screw and TP3598 nut.

#### PAWL, LEVER, AND SPRING COMBINATIONS

2.07 To remove the pawl, lever, and spring combinations (Figure 4), proceed as follows.

- (a) Remove chad chute assembly.
- (b) Remove punch block assembly.
- (c) Remove tape guide assembly.
- (d) Remove pawl upstop assembly.
- (e) Remove sensing levers and guideplate assembly.
- (f) Remove the two TP181244 screws that hold the power bail mechanism in place.
- (g) Remove the TP119652 retaining ring that holds the TP182377 pawl to the power bail assembly.
- (h) Remove the TP7002 flat washer, the TP124177 lockwasher, and the TP3598 nut from the TP185846 post that supplies the pivot point for the levers.
- (i) The pawl, lever, and spring combination and the attached power bail assembly can now be removed from the tape punch.
- (j) To replace the pawl, lever, and spring combination, reverse the procedure used to remove it.

33 COVER

GENERAL DESCRIPTION

CONTENTS	PAGE
1. GENERAL . . . . .	1
2. DESCRIPTION . . . . .	1
A. Receive-Only (RO) Cover . . . . .	1
B. Keyboard Send-Receive (KSR) Cover . . . . .	1
C. Automatic Send-Receive (ASR) Cover . . . . .	1

1. GENERAL

1.01 This section is reissued to provide a general description of the 33 cover. Information on the 32 cover presented in Issue 1 has been omitted and is covered in Section 574-176-100TC. Also omitted is information on adjustments, disassembly and reassembly, and lubrication which appeared in Issue 1. This information is now covered in the following sections:

- Disassembly and Reassembly - 574-100-702TC
- Adjustments - 574-126-700TC
- Lubrication - 574-126-701TC

Since this is a general revision marginal arrows have been omitted.

1.02 The main function of the cover is to protect the interior components of the set and serve as a decorative finish to the set. The cover also serves as the frame for the dial, lamps, volume control knob, and the paper supply.

1.03 References to left, right, front, or rear consider the cover as viewed by the operator.

2. DESCRIPTION

A. Receive-Only (RO) Cover

2.01 The RO cover houses the receiving component of the set. The cover is made entirely of plastic.

2.02 A spring detented lid, when raised, provides access to the ribbon. It also allows the operator to easily insert the paper around the platen. A window permits viewing the copy and provides a cutting edge for tearing paper or forms. The entire cover mounts to the set sub-base.

B. Keyboard Send-Receive (KSR) Cover

2.03 The KSR cover illustrated in Figure 1 houses the typing unit, the keyboard, and the call control unit. Like the RO cover, the KSR cover is gray and made of plastic.

2.04 The cover has a raisable lid to provide access to the paper and the ribbon as described in 2.02. In the call control area, the cover has slots for the various lamps, as shown in Figure 1, and an opening for the dial. The nameplate attaches to the front of the cover.

C. Automatic Send-Receive (ASR) Cover

2.05 The ASR cover illustrated in Figure 2 is essentially the same as the KSR except that covers for the tape punch and the tape reader are attached.

2.06 When mounted on the set the cover is one integral whole. The tape punch and the tape reader covers are attached to the main cover and remain as part of the main cover when it is removed. In the particular cover shown in Figure 2, a paper alarm is mounted to the rear of the cover beyond where the paper roll would be mounted. Like the RO and KSR covers, the ASR cover is also gray and plastic.

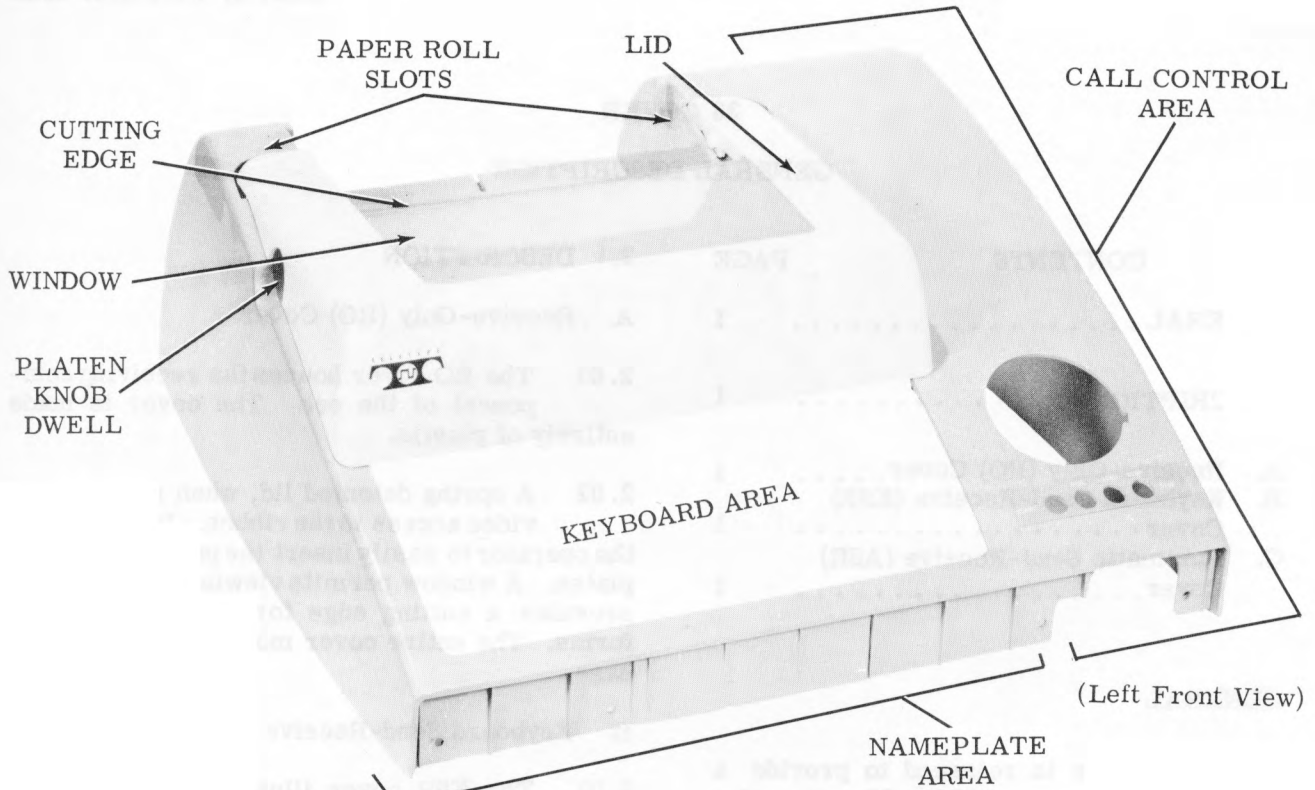

Figure 1 - Keyboard Send-Receive (KSR) Cover

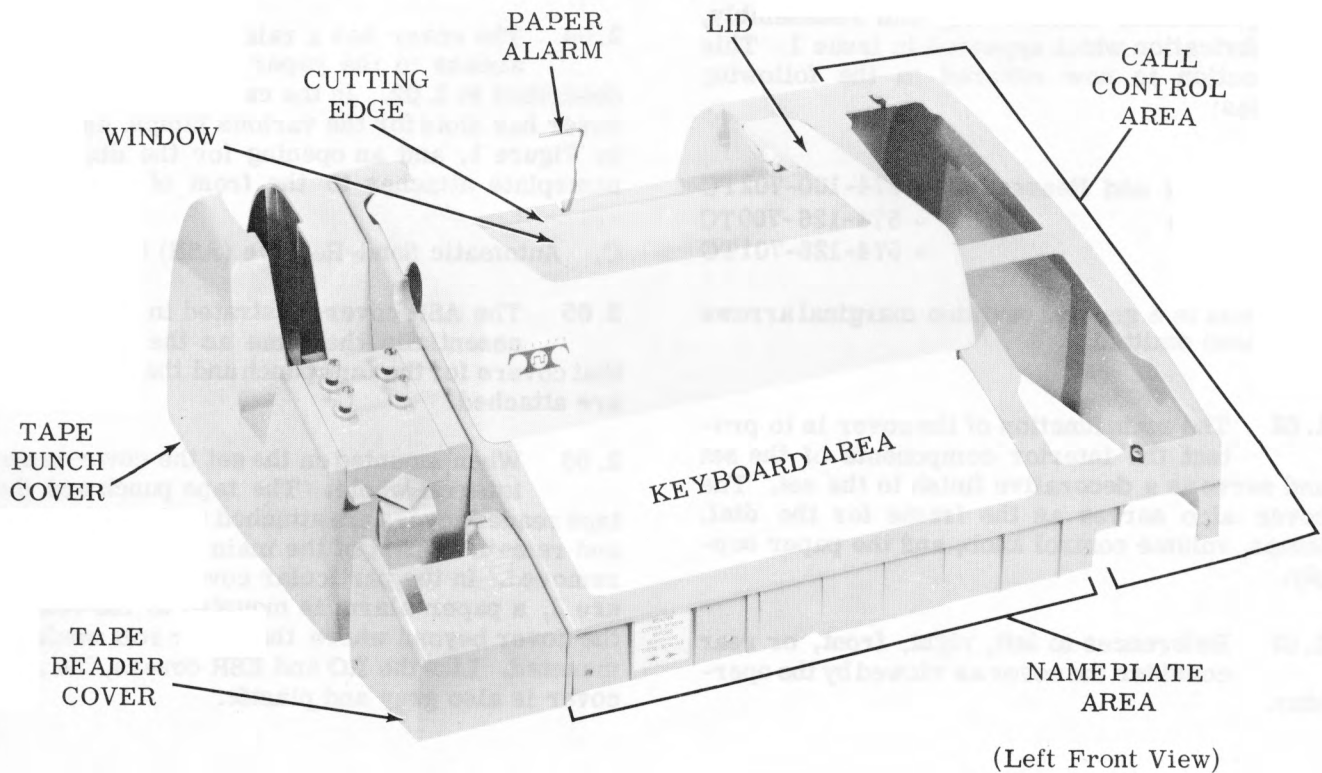

Figure 2 - Automatic Send-Receive (ASR) Cover

33 COVER

LUBRICATION

CONTENTS	PAGE
1. GENERAL . . . . .	1
2. COVER . . . . .	2
ASR Cover . . . . .	2
Lid. . . . .	2

lubricate the cover at regular unit lubrication intervals.

1.05 The textual instructions that accompany the line drawing consist of abbreviated directions, specific lubrication points, and parts affected. The meanings of the abbreviated directions (symbols) are given below:

<u>Symbol</u>	<u>Meaning</u>
D	Keep dry — no lubricant permitted.
O	Oil (KS7470)

1. GENERAL

1.01 This section provides lubrication information for the 33 cover formerly covered in Section 574-126-100TC.

1.02 The general lubrication area is shown in the automatic send-receive (ASR) cover photograph. Lubrication requirements are the same for both the keyboard send-receive (KSR) (not illustrated) and the ASR covers. The specific lubrication points are indicated on a line drawing with appropriate textual instructions keyed to the photograph by paragraph number.

1.03 Provide a thorough coat of lubricant at each designated area. Do not overlubricate to the point where lubricant drops onto adjacent parts.

1.04 Lubricate the cover before placing it into service or prior to storage. After a short period of service, relubricate it to make sure that no areas have been missed. Thereafter,

**CAUTION: DO NOT USE ALCOHOL, MINERAL SPIRITS, OR OTHER SOLVENTS TO CLEAN ANY PLASTIC PARTS OR PARTS WITH PROTECTIVE DECORATIVE FINISHES. NORMALLY, A SOFT, DRY CLOTH SHOULD BE USED TO REMOVE DUST, OIL, GREASE, OR OTHERWISE CLEAN PARTS OR SUBASSEMBLIES. IF NECESSARY, A SOFT DAMP CLOTH WITH SOAP OR A MILD DETERGENT MAY BE USED. AFTERWARDS, RINSE EACH CLEANED PART OR SUBASSEMBLY WITH A SOFT, DAMP CLOTH, AND BUFF WITH A SOFT, DRY CLOTH.**

1.06 Tools and materials needed for lubrication are listed in Section 570-005-800TC.

1.07 For disassembly and reassembly information, refer to Section 574-126-702TC.

2. COVER

2.01 ASR Cover

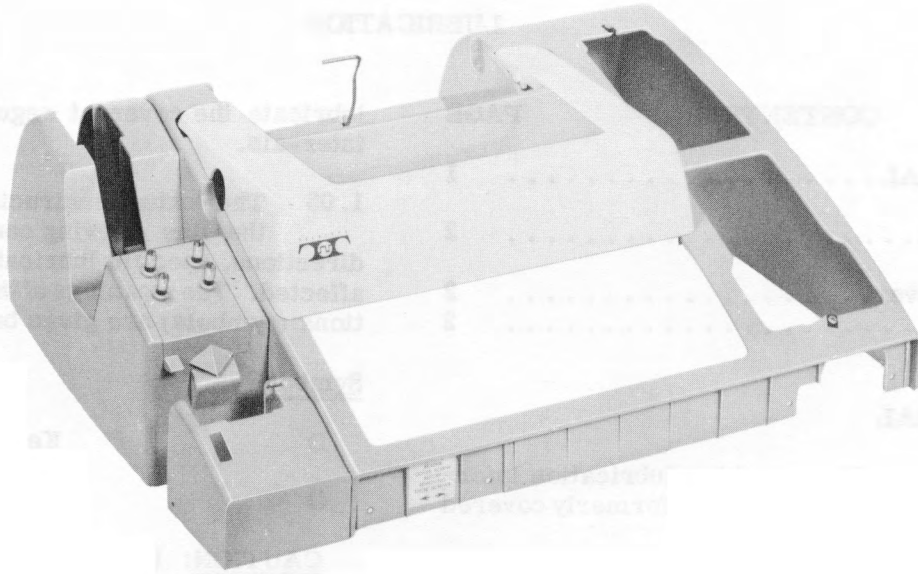

2.02 Lid

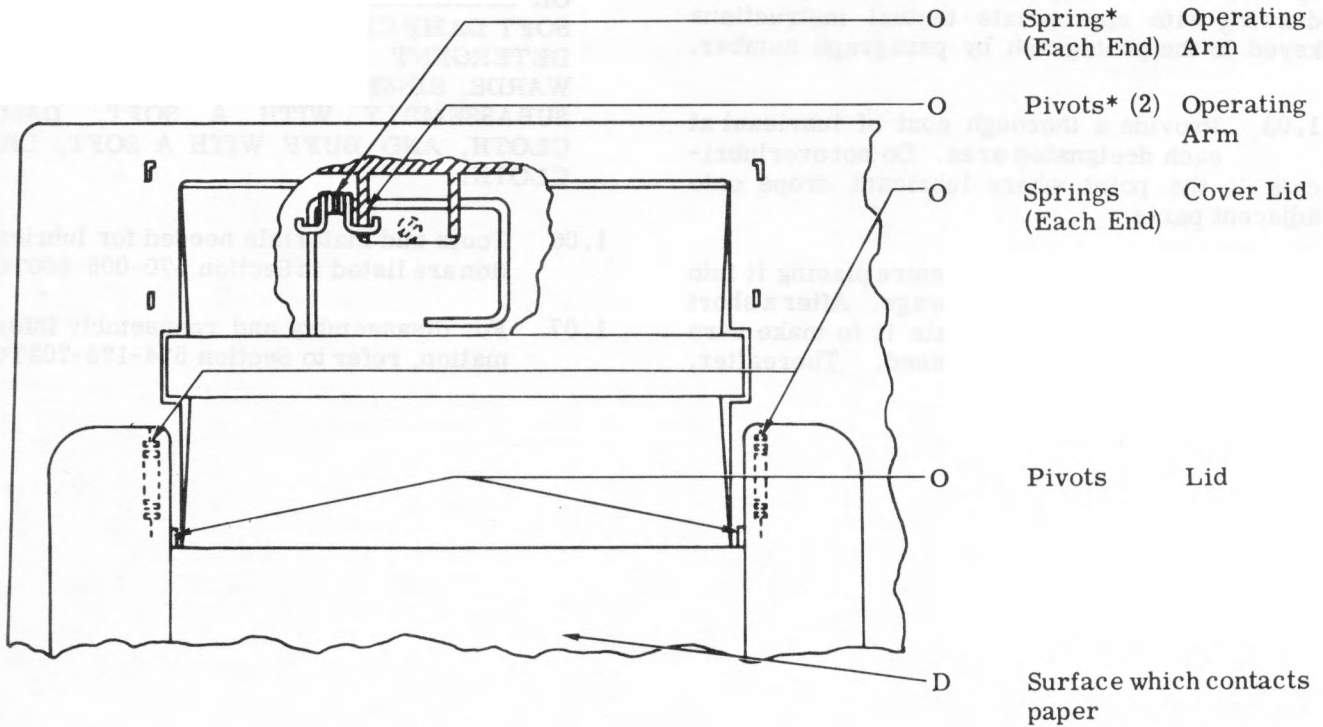

(Top View)

\*For covers equipped with TP181441 switch only.